

SPARE PARTS CATALOGUE - SM10

To avoid errors, when ordering please specify:

- Complete type of hoist
- Date of manufacture and serial number
- Spare part code
- Spare part designation
- Additional information

0) DESCRIPTION

1) HOIST MOTOR AND CASING

2) MECHANISM AND BRAKE

2.1) Double brake specific parts

3) LIFTING ASSEMBLY

3.1) Pre-cut chain

4) ELECTRIC CUBICLE FOR A VERSION

0) DESCRIPTION

Load capacity Capacité de charge	Type of hoist Type de palan	Models Modèles	Number of falls Nombre de brins	Type of chain Type de chaîne	
250 KG	SM102516M2	D	1	6.8x17.8	
500 KG	SM105016M1	A,B,C,E			
	SM10504M2	D			
	SM10508M2	D			
1000 KG	SM101004M1	A,B,C,E			2
	SM101008M1				
	SM101002M2	D			
	SM101004M2				
2000 KG	SM102002M1				
	SM102004M1				

Version inversée : Version A (std) ou version B,C,D,E
(option inversée)



Inverted : Version A (std) or Version B,C,D,E
(inverted option)

Version normale : Version B,C,D,E (std) ou Version
A (option)



Normal : Version B,C,D,E (Std) or Version A
(option)

1) HOIST MOTOR AND CASING

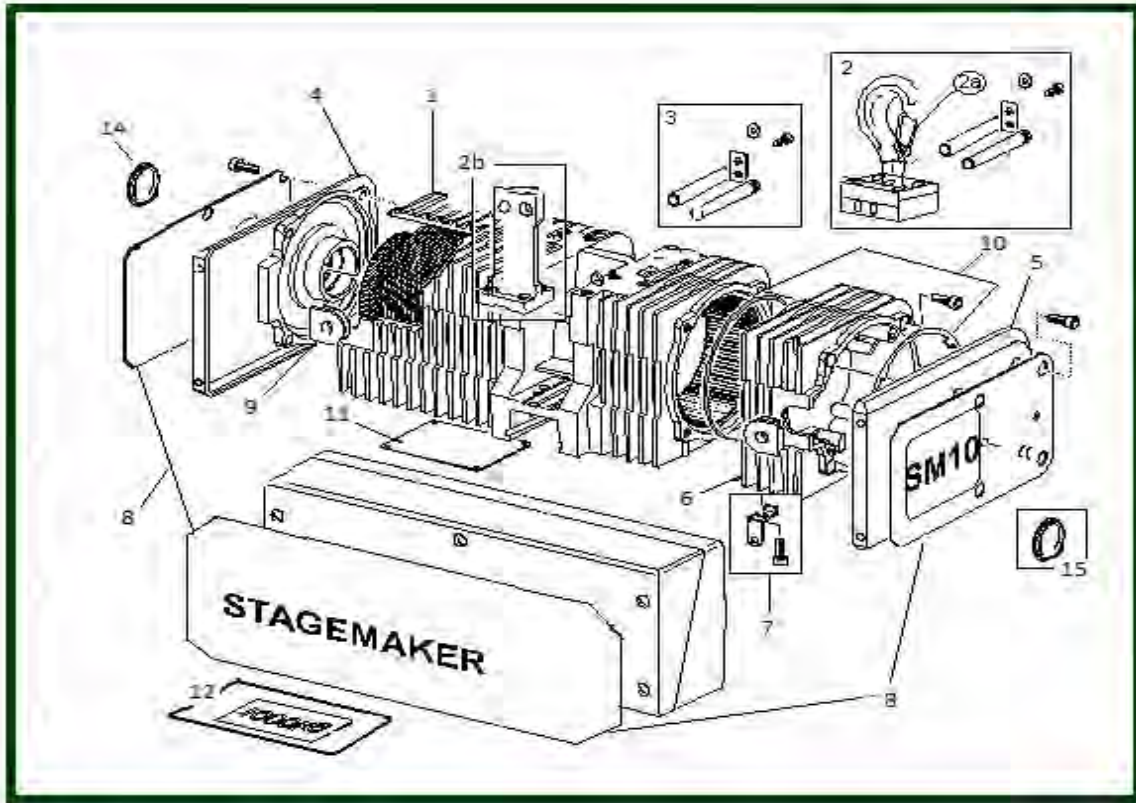

ITEM	REFERENCE	DESCRIPTION
1	2249974	Complete housing with gear rim and stator 30V 50Hz speed - 4P
1	2249967	Complete housing/gear rim and stator 230V 50Hz speeds - 2&8P
1	2249969	Complete housing/gear rim and stator 230V 60Hz speeds - 2&8P
1	2249973	Complete housing/gear rim/stator 400V 50Hz-460V 60Hz speed-4P
1	2249966	Complete housing/gear rim/stator 400V 50Hz-460V 60Hz sp-2&8P
1	2249968	Complete housing/gear rim and stator 400V 60Hz speeds - 2&8P
1	2249975	Complete housing/gear rim/stator 500V 50Hz-575V 60Hz speed-4P
1	2249970	Complete housing/gear rim/stator 500V 50Hz-575V 60Hz sp - 2&8P
2	52316240	Rotating lower hook assembly set Type A 1 (B,C,D,E)
2a	2242017	Safety latch-Steel plate C16 2 fall Suspension hook
2b	2242011	Suspension member
3	2247020	Hook suspension axle set
4	2249904	Motor end cap assembly Only for B-C-D version
4	52293407	Short flange - Motor side Only for A & E type hoist (direct voltage)
5	2249903	Brake end cap assembly
5	52293408	Short flange - Brake side Only for A & E type hoist (direct voltage)
6	2240011	Brake cap assembly

7	2218000	Button box fastening bracket
8	2246047	SM10 Stickers
9	2218004	Cable guide
10	2240013	Sea ring and O-ring for brake cap
11	2216520	Motor data plate - Only if serial number provided
12	2219929	Set of 10 load plates - Hoist 1250 Kg
12	2219920	Set of 10 load plates – Hoist 500 kg
12	2219921	Set of 10 load plates – Hoist 630 kg
12	2219922	Set of 10 load plates – Hoist 1000 kg
12	2219923	Set of 10 load plates – Hoist 1600 kg
12	2219924	Set of 10 load plates – Hoist 2000 kg
14	2218001	Plastic plug
15	52283279	Cap - Brake side
-	52334563	Canvas rain cover
-	2257018	Handle set - Set of 2

2) MECHANISM AND BRAKE

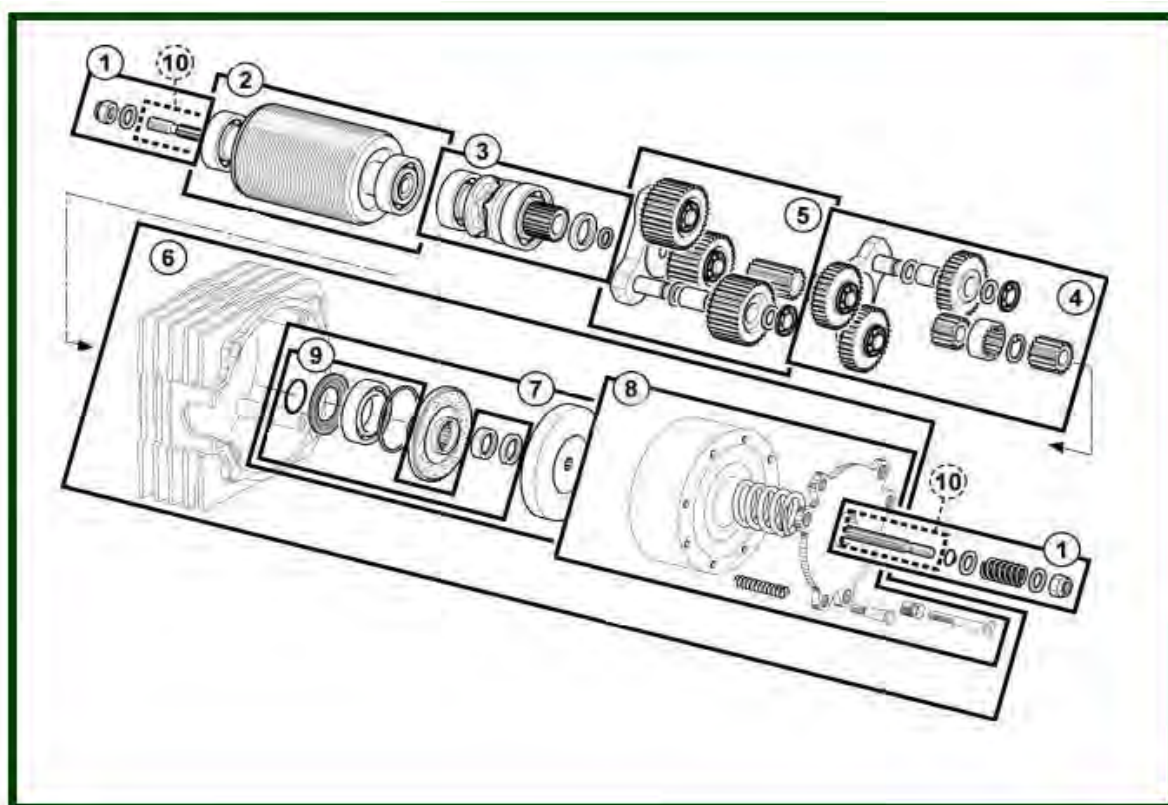

ITEM	REFERENCE	DESCRIPTION
1	2249940	Limiter spring with motor shaft

2	2245025	Rotor assembly 1 & 2 speeds
3	2249941	Chain sprocket assembly
4	2249938	Planetary gear train - 2nd step 8 m/min
4	2249951	Planetary gear train - 2nd step 16 m/min
5	2249937	Planetary gear train - 1st step
6	2241073	Complete brake assembly with brake cap 100VDC 230VAC
6	2241074	Complete brake assembly with brake cap 190VDC 400VAC
6	2241072	Complete brake assembly with brake cap 230VDC 500V 575VAC
7	2249972	Limiter friction assembly
8	2248000	Complete brake 100VDC 230VAC
8	2248001	Complete brake 190VDC 400VAC
8	2248003	Complete brake 230VDC 500V 575VAC
9	2240012	Set of seals for brake cap
10	2241501	Three motor

2.1) DOUBLE BRAKE SPECIFIC PARTS

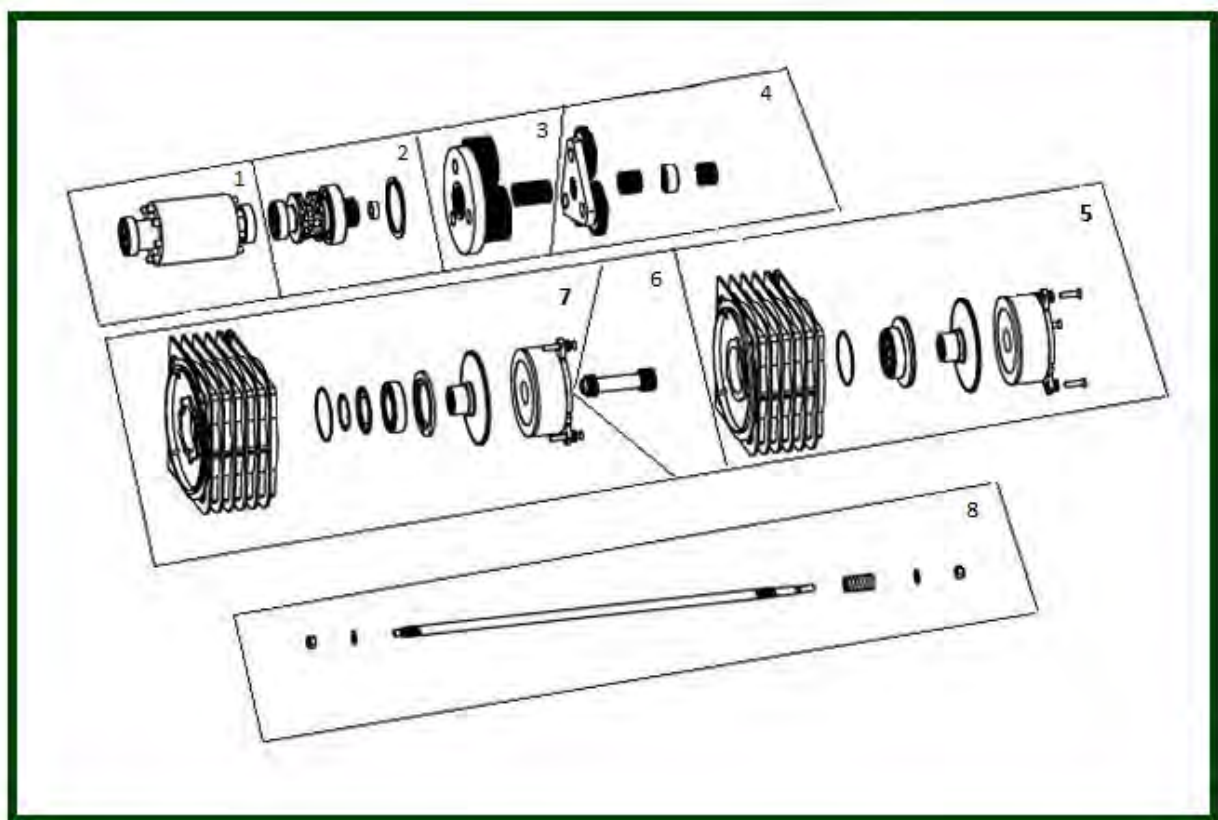

ITEM	REFERENCE	DESCRIPTION
1	2245025	Rotor assembly 1 & 2 speeds
2	2249941	Chain sprocket assembly

3	2249938	Planetary gear train - 2nd step 8 m/min
3	2249951	Planetary gear train - 2nd step 16 m/min
4	2249937	Planetary gear train - 1st step
5	2249016	1st Brake housing + brake 230VAC/100VDC
5	2249006	1st Brake housing + brake 400VAC/190VDC
6	2249054	Pinion
7	2249017	2nd Brake housing + brake 230VAC/100VDC
7	2249007	2nd Brake housing + brake 400VAC/190VDC
8	2249051	Motor shaft

3) LIFTING ASSEMBLY Version A

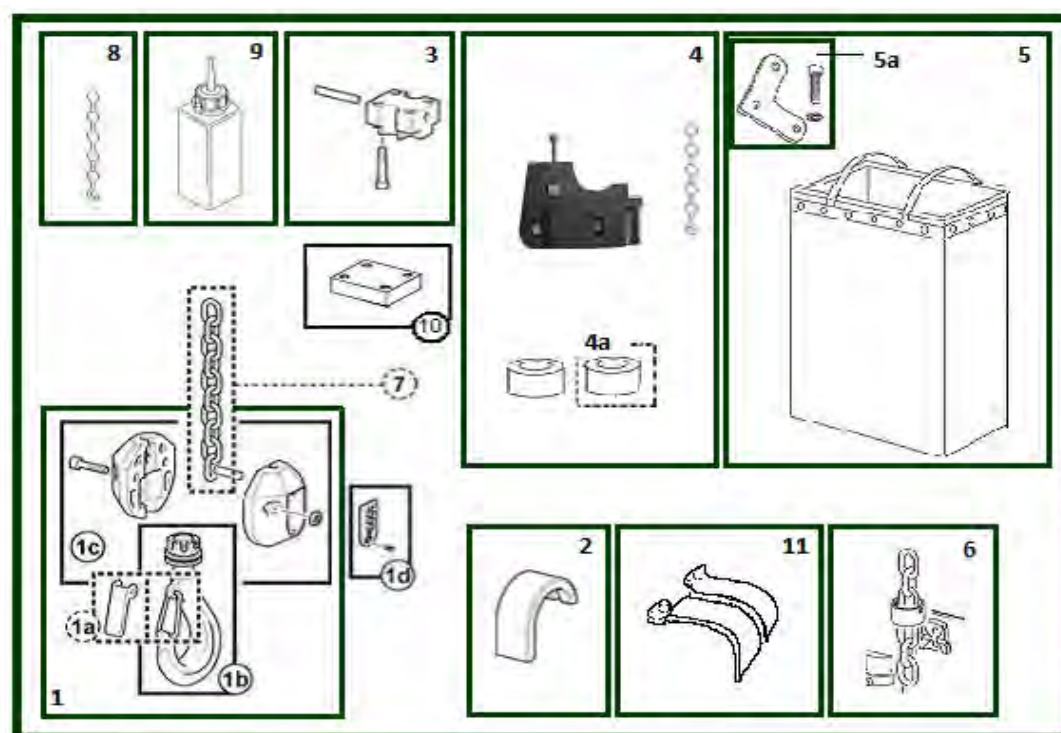

ITEM	REFERENCE	DESCRIPTION
1	52293146	Hook block 1 fall- 1000kg
1a	2212017	Safety latch - Steel plate type 1 fall
1b	2217004	Lifting hook - Standard type 1 fall
1c	52319867	Set of 2 half-casings with axle and screws 1 fall
1d	2249995	Set of 10 load plates - 1 fall 500 Kg
1d	2219939	Set of 10 load plates - 1 fall 630 Kg
1d	2219914	Set of 10 load plates - 1 fall 1000 Kg
2	2244011	Upper chain guide
3	2243523	Chain anchor assembly 2 falls

4	52425117	Aluminium chain guide set SM10 - HPR
4a	52313011	Rubber buffer (3 pieces)
5	52311223	Chain bag - 40 m - with carabiner version A
5	52328054	Chain bag - 50 m - with carabiner version A1 (B,C,D,E)
5b	2247019	Fixing plate set
6	2249942	Slack fall stop assembly
7	52322934	Black chain 6.8x17.8 - standard
7	2243501	Load chain - Black type - Only for cyber hoist
8	2241045	Load chain mounting tool
9	9995008	Can of oil for chain for chain-125 ml
10	2243522	Anchor point for hoist 2/1- only to modify the hoist 2/1
12	NC(5)	External chain guide - replaced by 52309591

3.1) PRE-CUT CHAIN

ITEM	REFERENCE	DESCRIPTION
	53019908	Black load chain - 6.8x17.8-20 metres
	53019909	Black load chain - 6.8x17.8-24 metres
	53019912	Black load chain - 6.8x17.8-100 metres

4) ELECTRIC CUBICLE FOR A VERSION

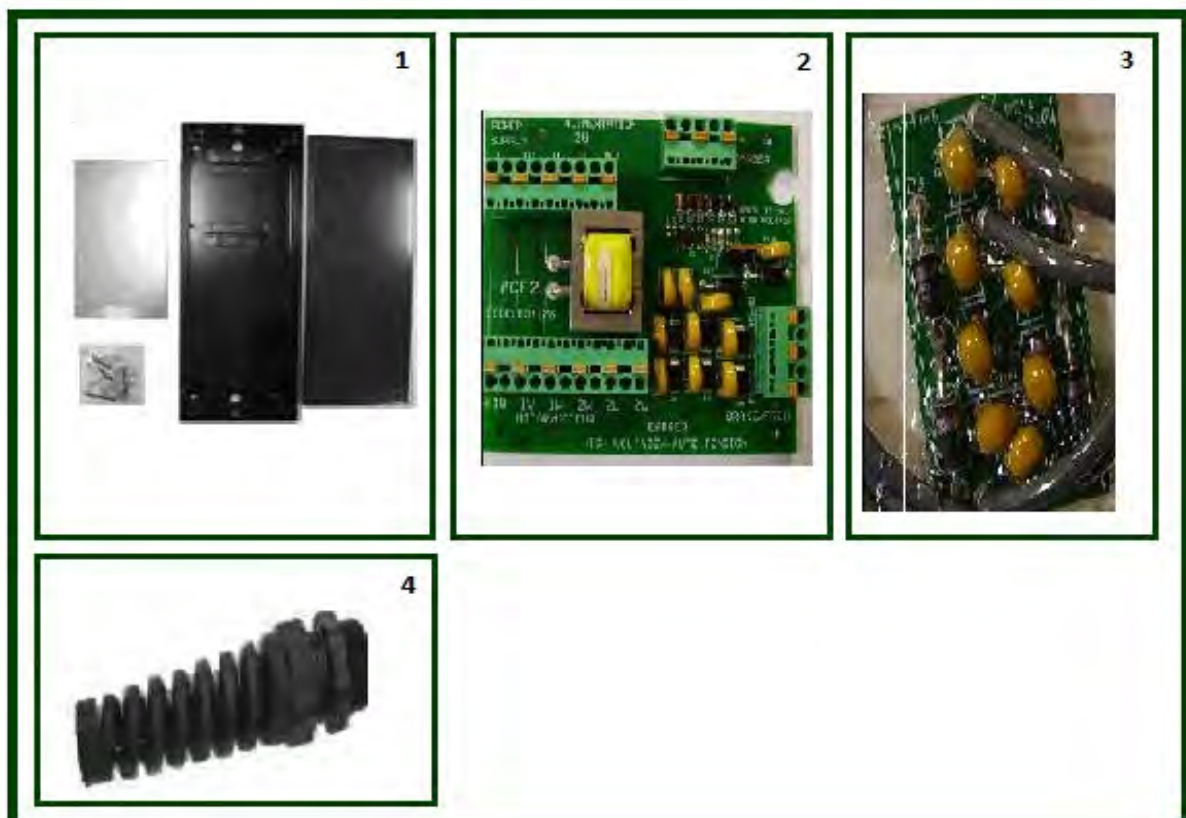

ITEM	REFERENCE	DESCRIPTION
1	52353908	Double brake electric cubicle
1	2243010	Electric cubicle (lid, cover, and screws) metal
1	52292683	SM10 thin metal electrical cubicle -A type hoist (direct voltage)
2	834176	ACF PC Board - For A type hoist (direct voltage)
3	2243060	Std rectifier – 230-575V C05 - C25 Standard hoist or Stagemaker E type hoist (direct voltage)
4	52283994	Spiral cable gland
-	52293328	Filter for encoder bearing
-	52292671	Red power supply plug 3P+ E - For A type hoist