

SPARE PARTS CATALOGUE - SR01

To avoid errors, when ordering please specify:

- Complete type of hoist
- Date of manufacture and serial number
- Spare part code
- Spare part designation
- Additional information



1) FRAME

- 1.1) Suspension eye
- 1.2) Suspension hook
- 1.3) Swivel hook

2) CHAIN GUIDE

- 2.1) Version A - 1 fall
- 2.2) Version A - 2 fall
- 2.3) Version B - 1 fall
- 2.4) Version B - 2 fall

3) GEAR

- 3.1) Single brake
- 3.2) Double brake

4) ELECTRICAL PARTS

- 4.1) Version A
- 4.2) Version B with CE plug
- 4.3) Version B with HARTING plug

1) FRAME

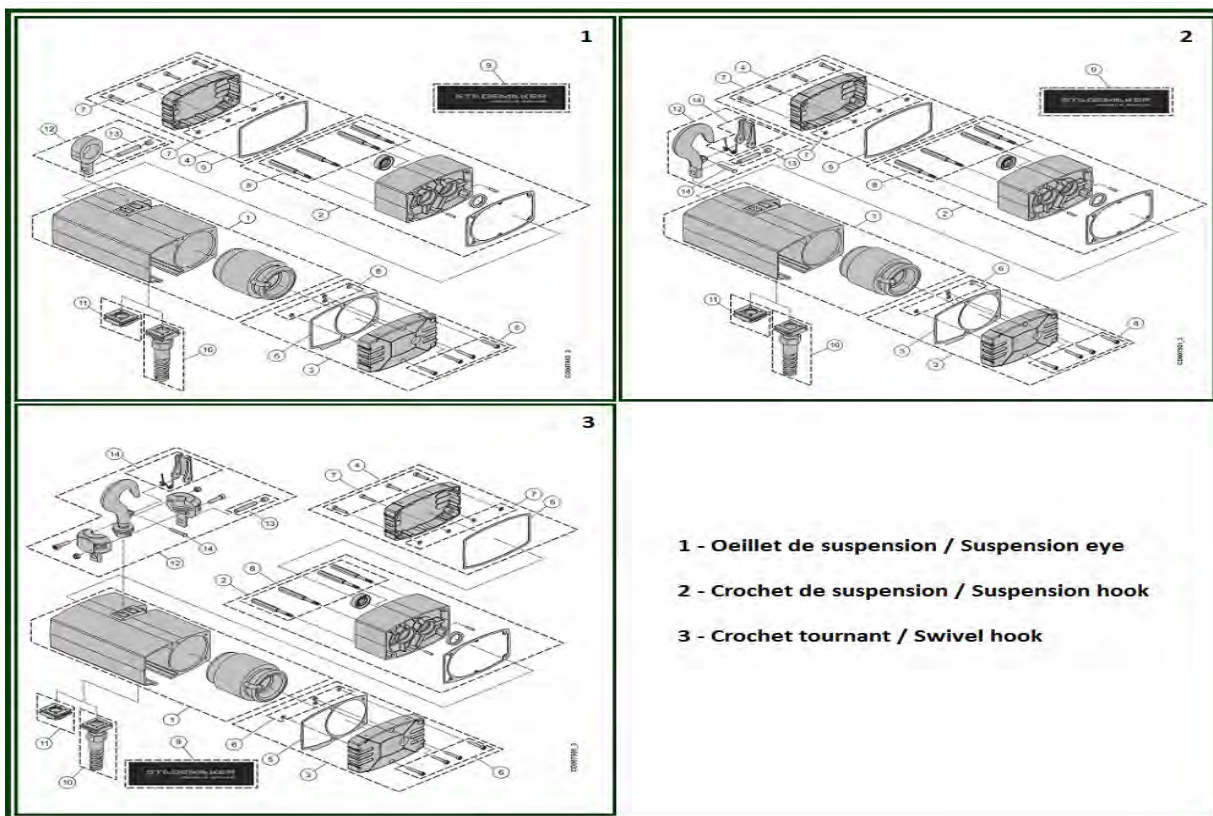

1.1) SUSPENSION EYE

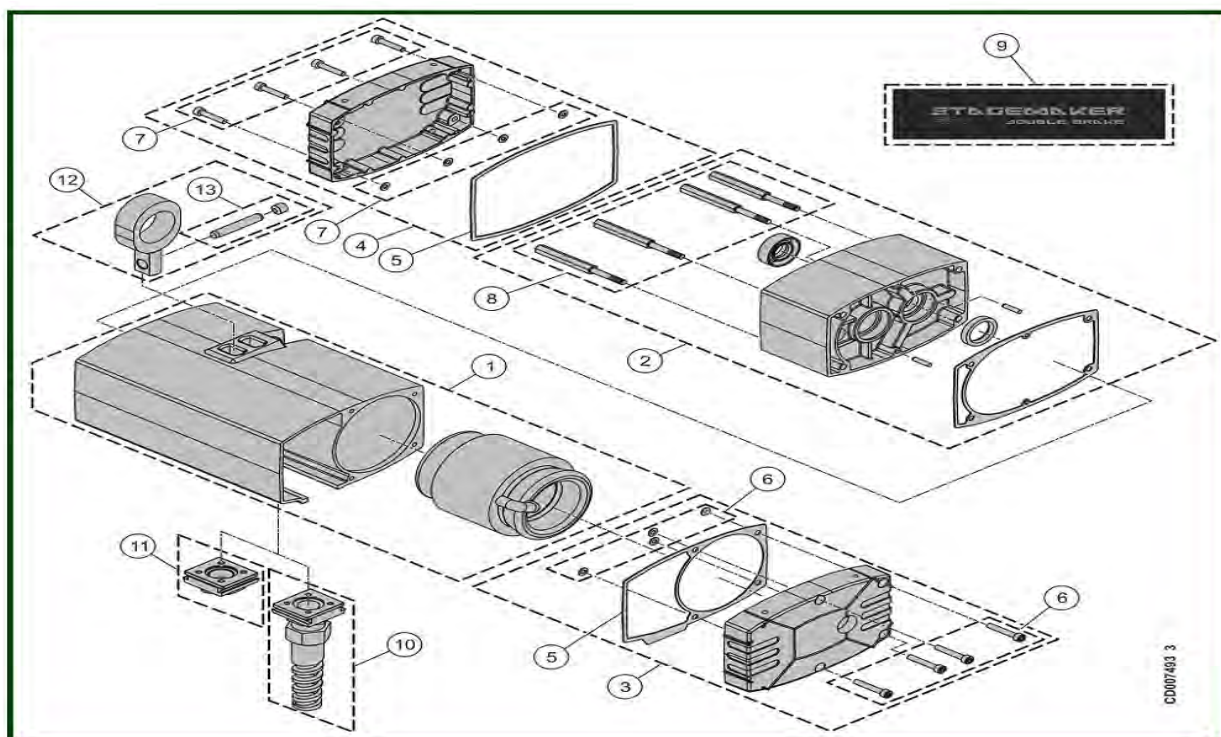

ITEM	REFERENCE	DESCRIPTION
1	VT0007170	Stator module - 208V 230V 60HZ 16 ² T
1	VT0007171	Stator module - 230V 50HZ 15 ² T
1	VT0007172	Stator module - 380V 400V 440V 50HZ 15 ² T 460V 480V 60HZ
2	VT0007175	Frame - Gear side - Double brakes

2	VT0007176	Frame - Gear side - Single brake
3	VT0007185	Cover set - Motor side
4	VT0007151	Cover set - Brake side
5	VT0007177	Seal set
6	VT0007186	Screw set M5X30 - Motor side
7	VT0007187	Screw set M5X30 - Brake side
8	VT0007198	Screw set - Double brakes
8	VT0007199	Screw set - Single brake
9	VT0007174	Identification plate brand – Hoist - Double brakes
9	VT0007173	Identification plate brand – Hoist - Single brake
10	VT0006950	Cable gland - Square cable entry
11	VT0007034	End cap - Square cable entry - PE ISO 25
12	VT0007227	Suspension eye set
13	VT0007230	Shaft set
-	VT0006026	Identification plate – Motor (Serial number required)
-	VT0007190	Rain Cover
-	VT0007188	Set of 2 handles

1.2) SUSPENSION HOOK

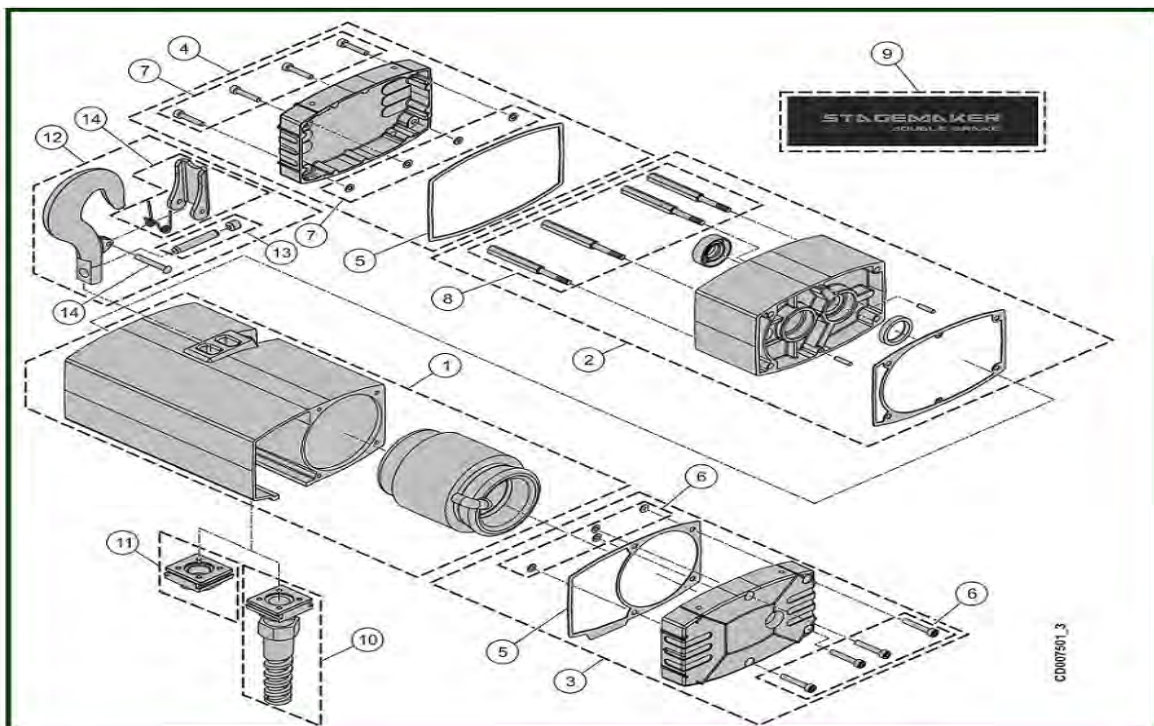

ITEM	REFERENCE	DESCRIPTION
1	VT0007170	Stator module - 208V 230V 60HZ 16 ² T

1	VT0007171	Stator module - 230V 50HZ 15 ² T
1	VT0007172	Stator module - 380V 400V 440V 50HZ 15 ² T 460V 480V 60HZ
2	VT0007175	Frame - Gear side - Double brakes
2	VT0007176	Frame - Gear side - Single brake
3	VT0007185	Cover set - Motor side
4	VT0007151	Cover set - Brake side
5	VT0007177	Seal set
6	VT0007186	Screw set M5X30 - Motor side
7	VT0007187	Screw set M5X30 - Brake side
8	VT0007198	Screw set - Double brakes
8	VT0007199	Screw set - Single brake
9	VT0007174	Identification plate brand – Hoist - Double brakes
9	VT0007173	Identification plate brand – Hoist - Single brake
10	VT0006950	Cable gland - Square cable entry
11	VT0007034	End cap - Square cable entry - PE ISO 25
12	VT0007228	Suspension hook
13	VT0007230	Shaft set
14	VT0007197	Safety latch - Swivel hook and suspension hook
-	VT0006026	Identification plate – Motor (Serial number required)
-	VT0007190	Rain Cover
-	VT0007188	Set of 2 handles

1.3) SWIVEL HOOK

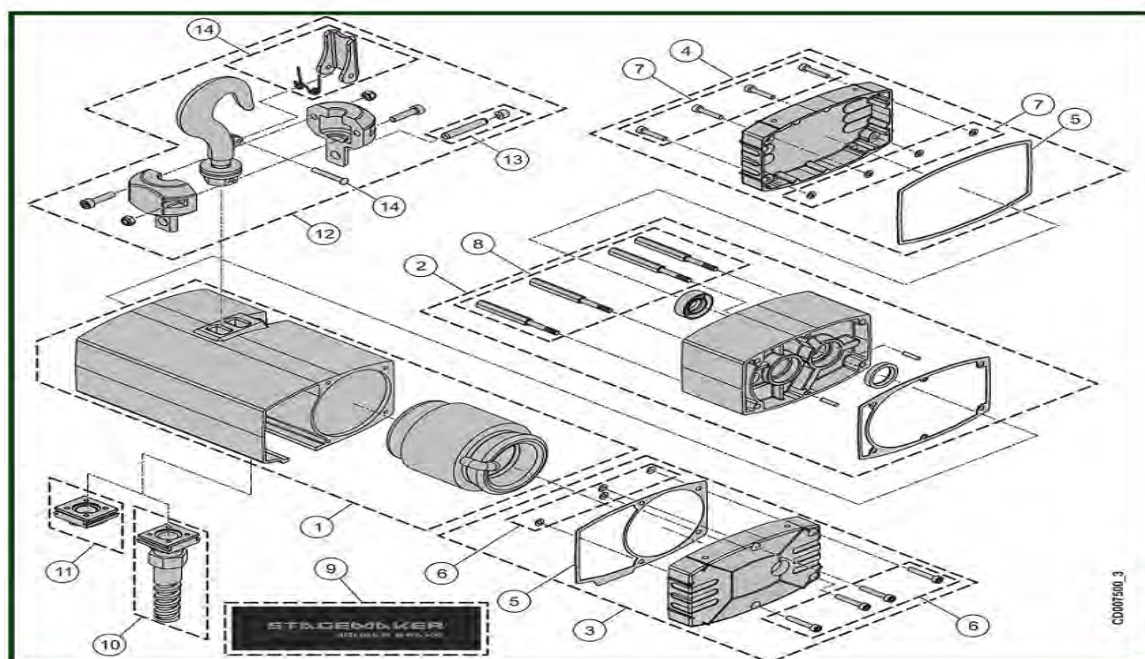

ITEM	REFERENCE	DESCRIPTION
1	VT0007170	Stator module - 208V 230V 60HZ 16 ² T
1	VT0007171	Stator module - 230V 50HZ 15 ² T
1	VT0007172	Stator module - 380V 400V 440V 50HZ 15 ² T 460V 480V 60HZ
2	VT0007175	Frame - Gear side - Double brakes
2	VT0007176	Frame - Gear side - Double brakes
3	VT0007185	Cover set - Motor side
4	VT0007151	Cover set - Brake side
5	VT0007177	Seal set
6	VT0007186	Screw set M5X30 - Motor side
7	VT0007187	Screw set M5X30 - Brake side
8	VT0007198	Screw set - Double brakes
8	VT0007199	Screw set - Single brake
9	VT0007174	Identification plate brand – Hoist - Double brakes
9	VT0007173	Identification plate brand – Hoist - Single brake
10	VT0006950	Cable gland - Square cable entry
11	VT0007034	End cap - Square cable entry - PE ISO 25
12	VT0007229	Swivel hook
13	VT0007230	Shaft set
14	VT0007197	Safety latch - Swivel hook and suspension hook
-	VT0006026	Identification plate – Motor Serial number required
-	VT0007190	Rain Cover
-	VT0007188	Set of 2 handles

2) CHAIN GUIDE

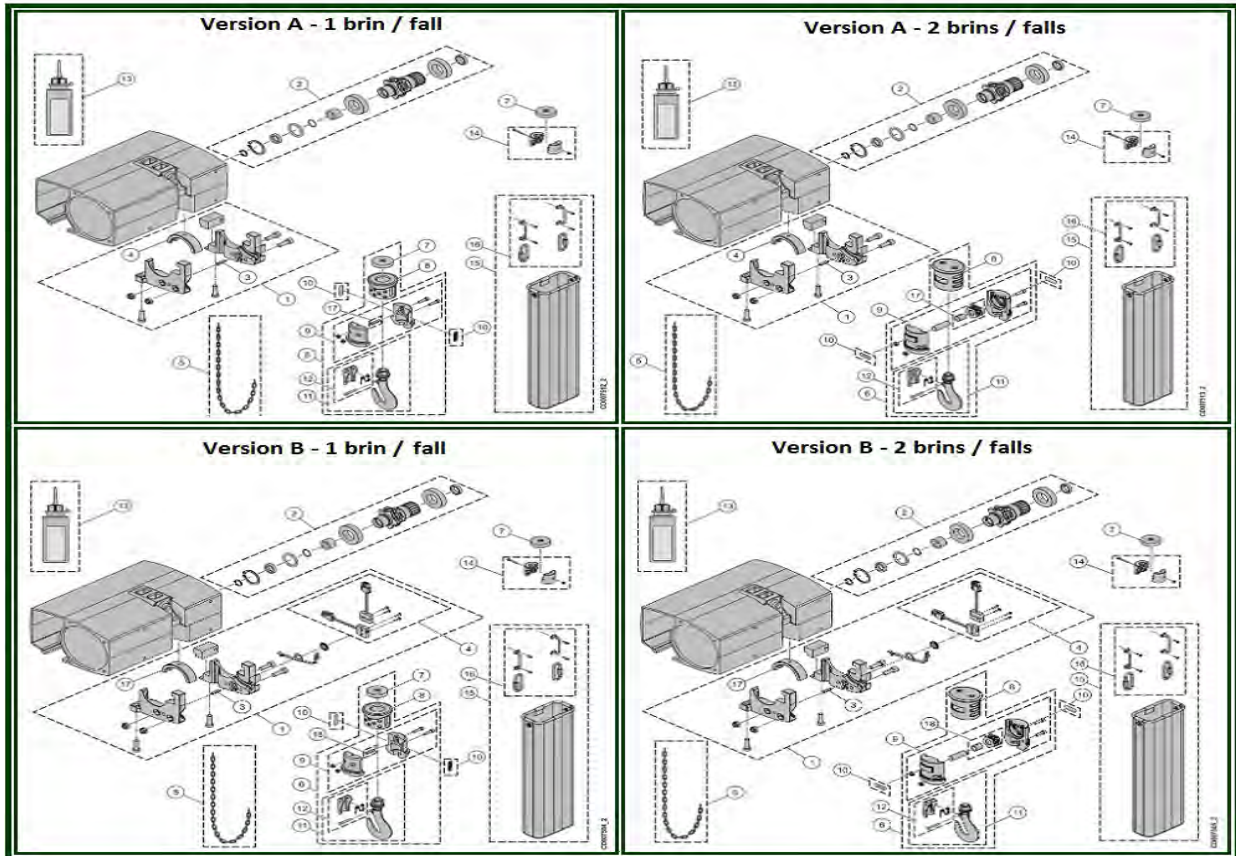

2.1) VERSION A - 1 FALL

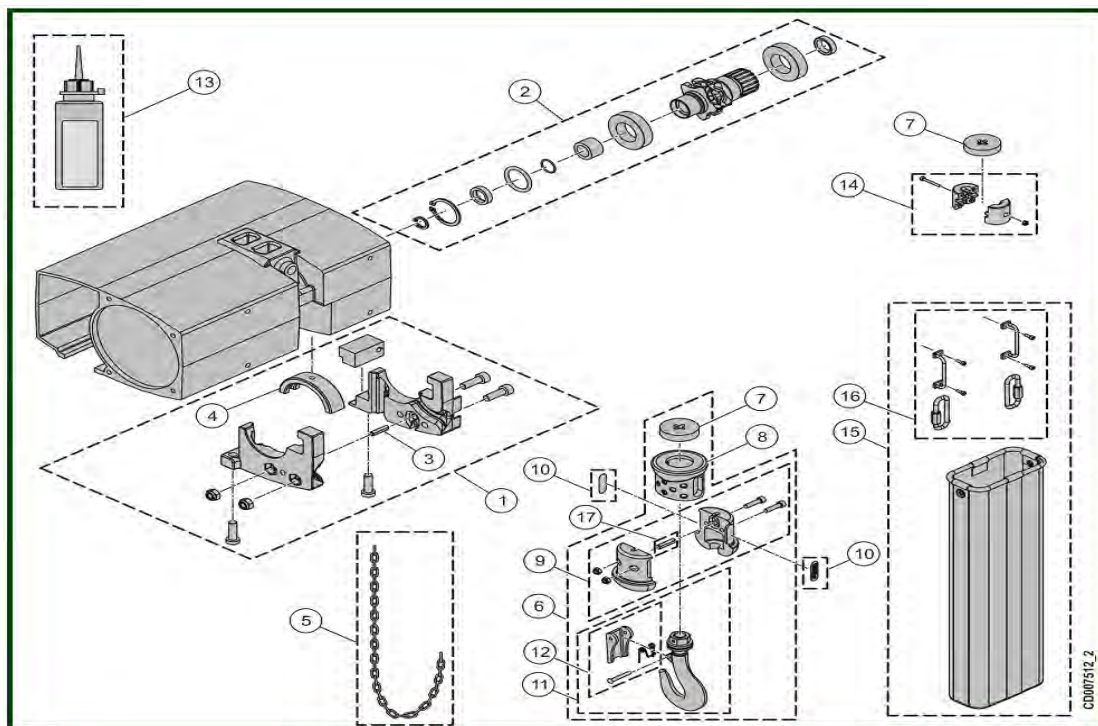

ITEM	REFERENCE	DESCRIPTION
------	-----------	-------------

1	VT0007226	Chain guide assembly
---	-----------	----------------------

2	VT0007202	Chain sprocket
---	-----------	----------------

3 & 17	VT0006093	Shaft
--------	-----------	-------

4	VT0007178	Upper chain guide
5	VT0005997	Black chain 4x11
6	VT0007181	Hook block automatic module 1 fall
6	VT0007179	Hook block standard module 1 fall
7	VT0007711	Rubber buffer Ø40
8	VT0007183	Rubber sleeve 1 fall
9	VT0007205	Half casing set 1 fall
10	VT0006996	Set of 10 load plates – Hoist 125 Kg
10	VT0006091	Set of 10 load plates – Hoist 250 Kg
10	VT0006031	Set of 10 load plates – Hoist 250 kg - 4 m/min
10	VT0006243	Set of 10 load plates – Hoist 500 kg
10	VT0007208	Set of 10 load plates – Hoist 500 Kg - 2 m/min
11	VT0007184	Hook standard lower 1+2 falls
11	VT0006427	Lower hook assembly Automatic 1+2 falls
12	VT0007197	Safety latch Swivel hook and suspension hook
13	VT0006025	Oil can
14	VT0007215	Chain stop
15	VT0007218	Chain bucket 16 m
15	VT0007217	Chain bucket 20 m
15	VT0007216	Chain bucket 30 m
16	VT0007219	Fixing set / Chain bucket

2.2) VERSION A - 2 FALL

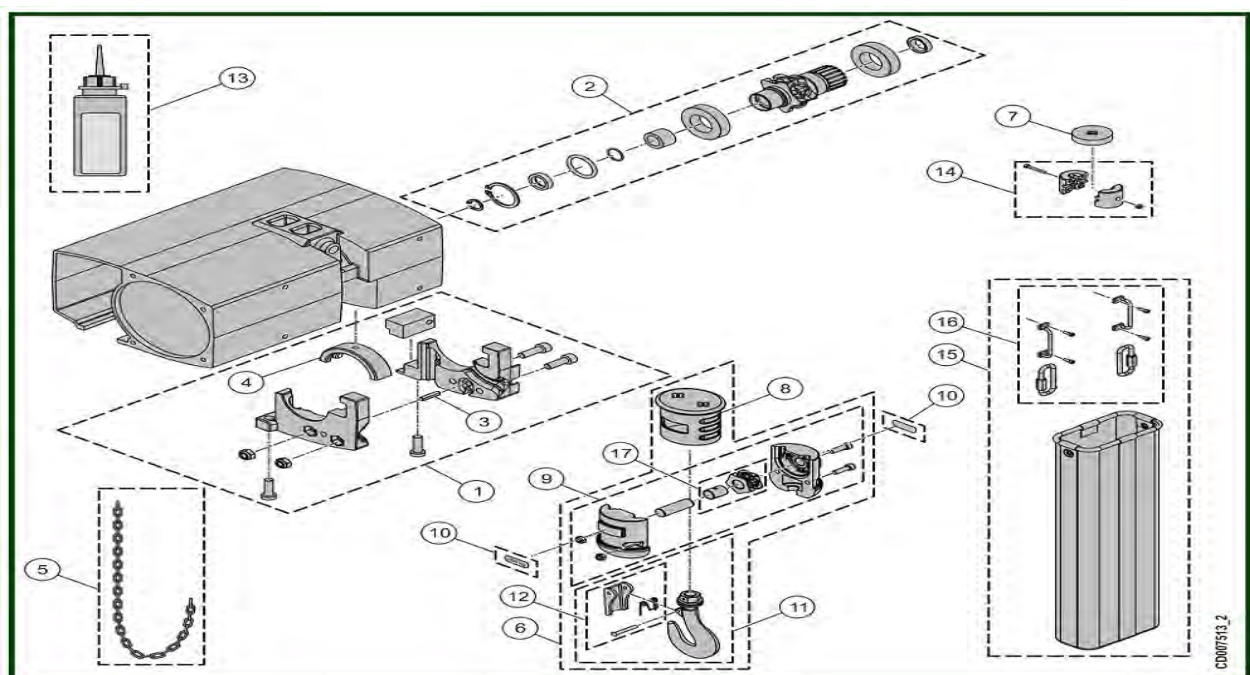

ITEM	REFERENCE	DESCRIPTION
1	VT0007226	Chain guide assembly
2	VT0007202	Chain sprocket
3	VT0006093	Shaft
4	VT0007178	Upper chain guide
5	VT0005997	Black chain 4x11
6	VT0007182	Bottle block automatic module 2 falls
6	VT0007180	Bottle block standard module 2 falls
7	VT0007711	Rubber buffer Ø40
8	VT0007191	Rubber chain stop
9	VT0007206	Half casing set 2 falls
10	VT0006996	Set of 10 load plates – Hoist 125 Kg
10	VT0006091	Set of 10 load plates – Hoist 250 Kg
10	VT0006031	Set of 10 load plates – Hoist 250 kg - 4 m/min
10	VT0007208	Set of 10 load plates – Hoist 500 Kg - 2 m/min
11	VT0007184	Hook standard lower 1+2 falls
11	VT0006427	Lower hook assembly Automatic 1+2 falls
12	VT0007197	Safety latch Swivel hook and suspension hook
13	VT0006025	Oil can
14	VT0007215	Chain stop
15	VT0007218	Chain bucket 16 m
15	VT0007217	Chain bucket 20 m
15	VT0007216	Chain bucket 30 m
16	VT0007219	Fixing set / Chain bucket
17	VT0007220	Return sprocket

2.3) VERSION B - 1 FALL

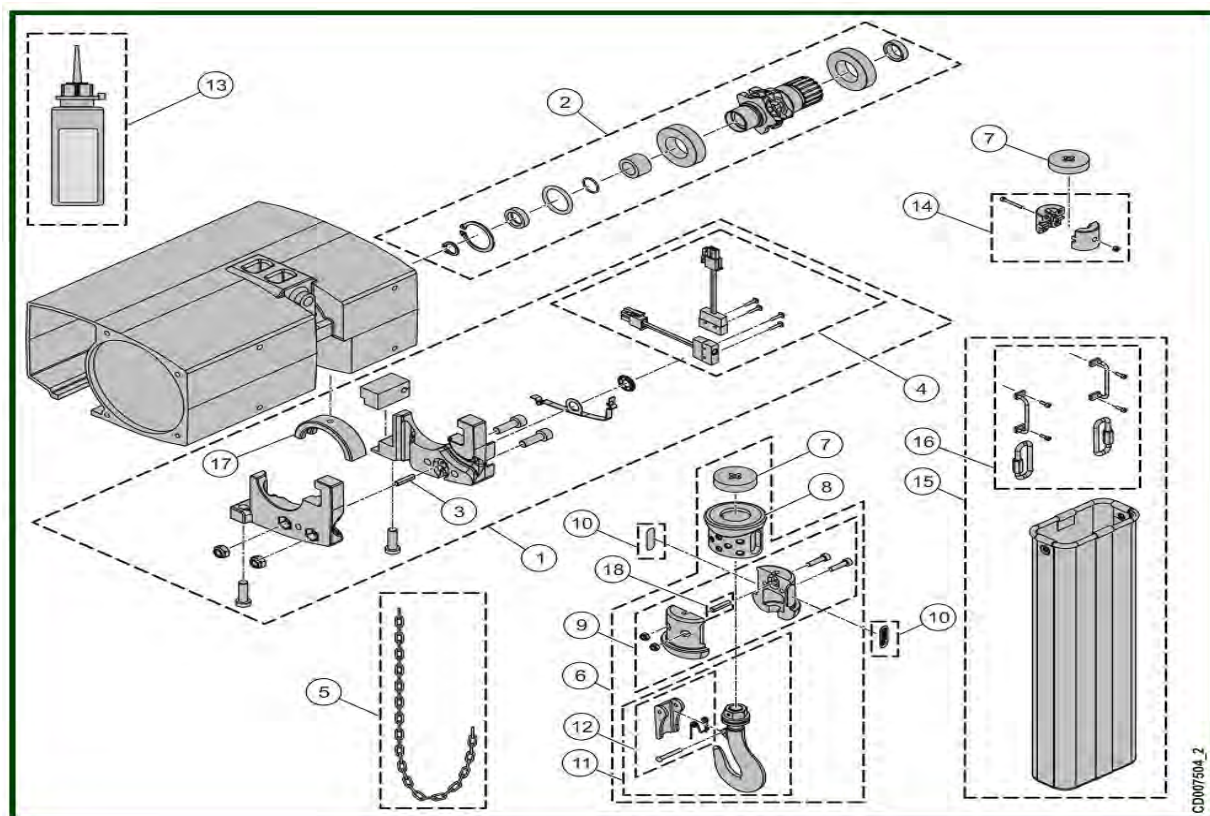

ITEM	REFERENCE	DESCRIPTION
1	VT0007225	Chain guide / assembly Upper and lower
2	VT0007202	Chain sprocket
4	VT0007203	Switch set
5	VT0005997	Black chain 4x11
6	VT0007181	Hook block automatic module 1 fall
6	VT0007179	Hook block standard module 1 fall
7	VT0007711	Rubber buffer $\varnothing 40$
8	VT0007183	Rubber sleeve 1 fall
9	VT0007205	Half casing set 1 fall
10	VT0006996	Set of 10 load plates – Hoist 125 Kg
10	VT0006091	Set of 10 load plates – Hoist 250 Kg
10	VT0006031	Set of 10 load plates – Hoist 250 kg - 4 m/min
10	VT0006243	Set of 10 load plates – Hoist 500 kg
10	VT0007208	Set of 10 load plates – Hoist 500 Kg - 2 m/min
11	VT0007184	Hook standard lower 1+2 falls
11	VT0006427	Lower hook assembly Automatic 1+2 falls

12	VT0007197	Safety latch Swivel hook and suspension hook
13	VT0006025	Oil can
14	VT0007215	Chain stop
15	VT0007218	Chain bucket 16 m
15	VT0007217	Chain bucket 20 m
15	VT0007216	Chain bucket 30 m
16	VT0007219	Fixing set / Chain bucket
17	VT0007178	Upper chain guide
18	VT0006093	Shaft

2.4) VERSION B - 2 FALL

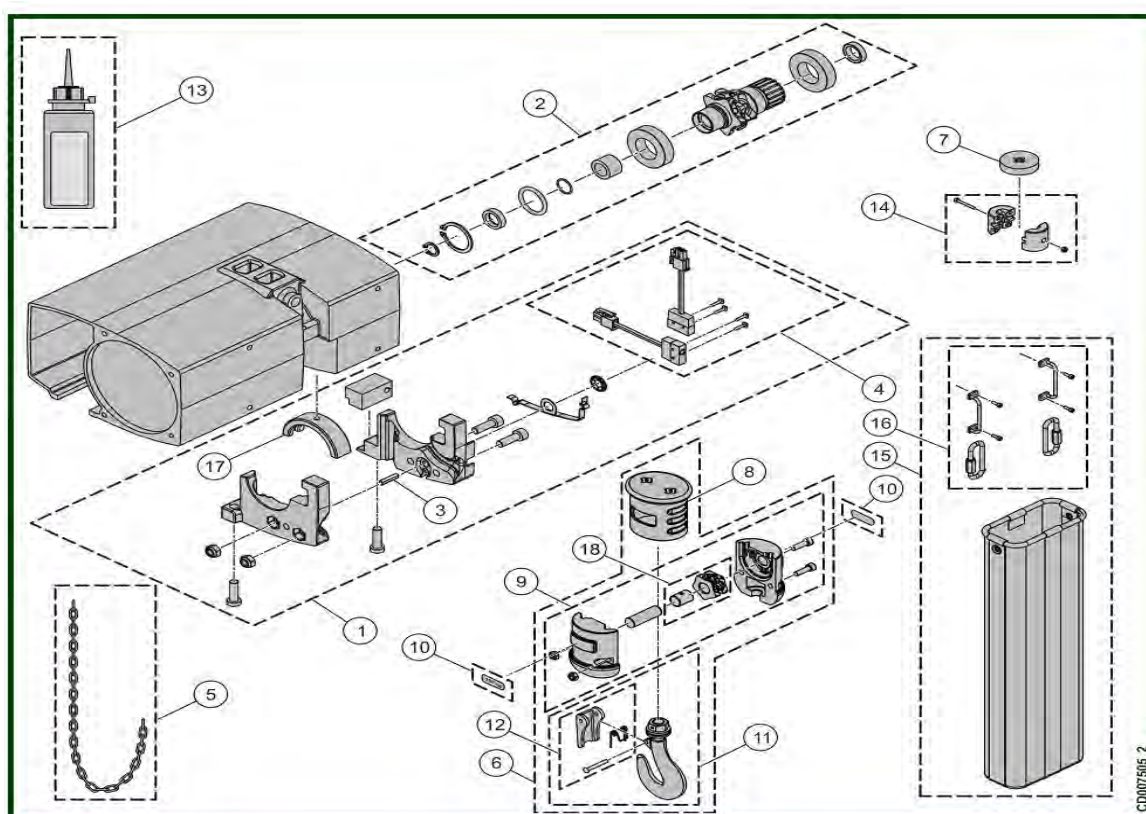

ITEM	REFERENCE	DESCRIPTION
1	VT0007225	Chain guide / assembly Upper and lower
2	VT0007202	Chain sprocket
3	VT0006093	Shaft
4	VT0007203	Switch set
5	VT0005997	Black chain 4x11
6	VT0007182	Bottle block automatic module 2 falls
6	VT0007180	Bottle block standard module 2 falls
7	VT0007711	Rubber buffer $\varnothing 40$

8	VT0007191	Rubber chain stop
9	VT0007206	Half casing set 2 falls
10	VT0006996	Set of 10 load plates – Hoist 125 Kg
10	VT0006091	Set of 10 load plates – Hoist 250 Kg
10	VT0006031	Set of 10 load plates – Hoist 250 kg - 4 m/min
10	VT0006243	Set of 10 load plates – Hoist 500 kg
10	VT0007208	Set of 10 load plates – Hoist 500 Kg - 2 m/min
11	VT0007184	Hook standard lower 1+2 falls
11	VT0006427	Lower hook assembly Automatic 1+2 falls
12	VT0007197	Safety latch Swivel hook and suspension hook
13	VT0006025	Oil can
14	VT0007215	Chain stop
15	VT0007218	Chain bucket 16 m
15	VT0007217	Chain bucket 20 m
15	VT0007216	Chain bucket 30 m
16	VT0007219	Fixing set / Chain bucket
17	VT0007178	Upper chain guide
18	VT0007220	Return sprocket

3) GEAR

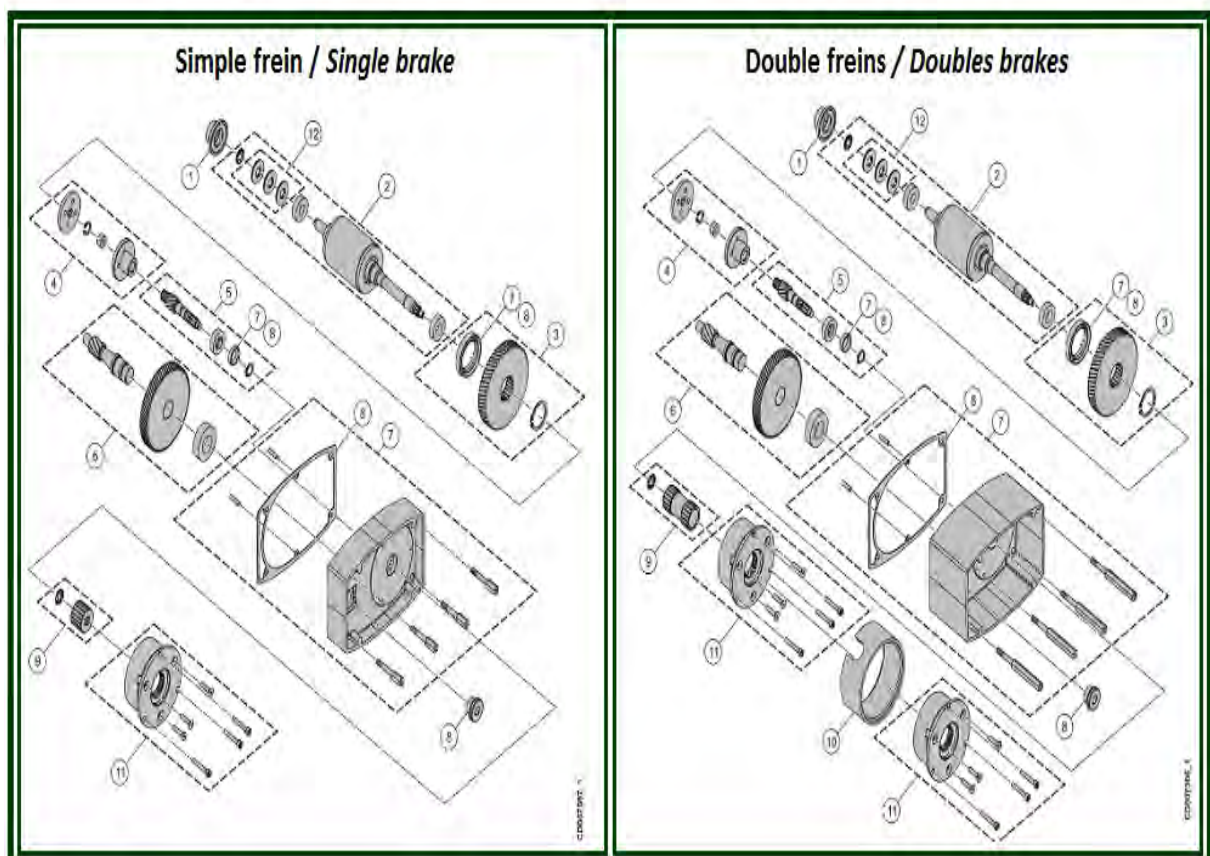

3.1) SINGLE BRAKE

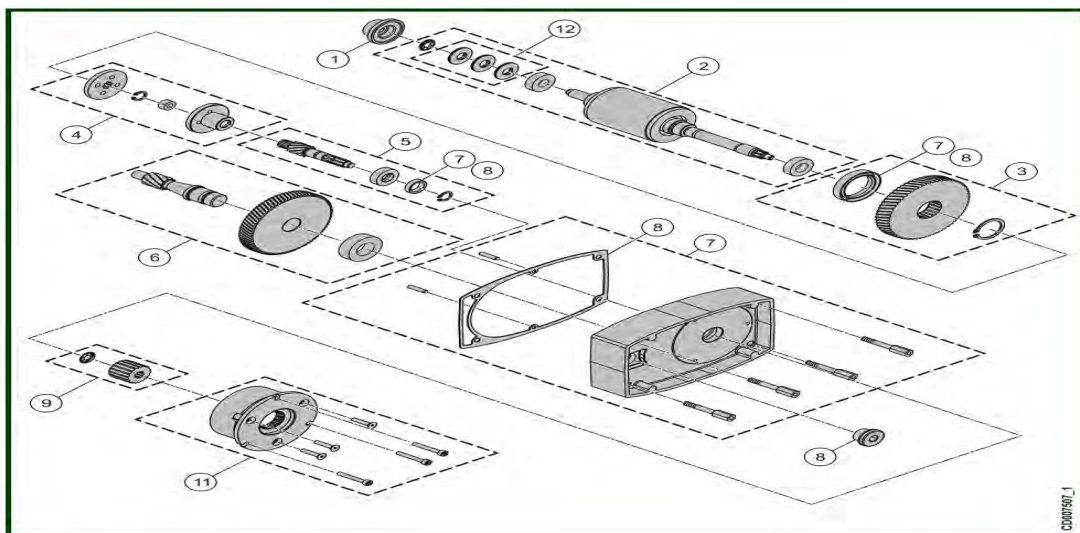

ITEM	REFERENCE	DESCRIPTION
1	VT0007214	Clutch adjusting screw
2	VT0007221	Rotor module
3	VT0007231	Gear set - 1st step
4	VT0007232	Friction disc + Clutch set
5	VT0007233	Set gear shaft
6	VT0007222	Gear
7	VT0007176	Frame - Gear side Single brake
8	VT0007234	Set sealing
9	VT0007236	Set brake hub Single brake
11	VT0007239	Set brake 103V-230V
11	VT0007593	Set brake 190V-400V
12	VT0007238	Set Belleville washer

3.2) DOUBLE BRAKE

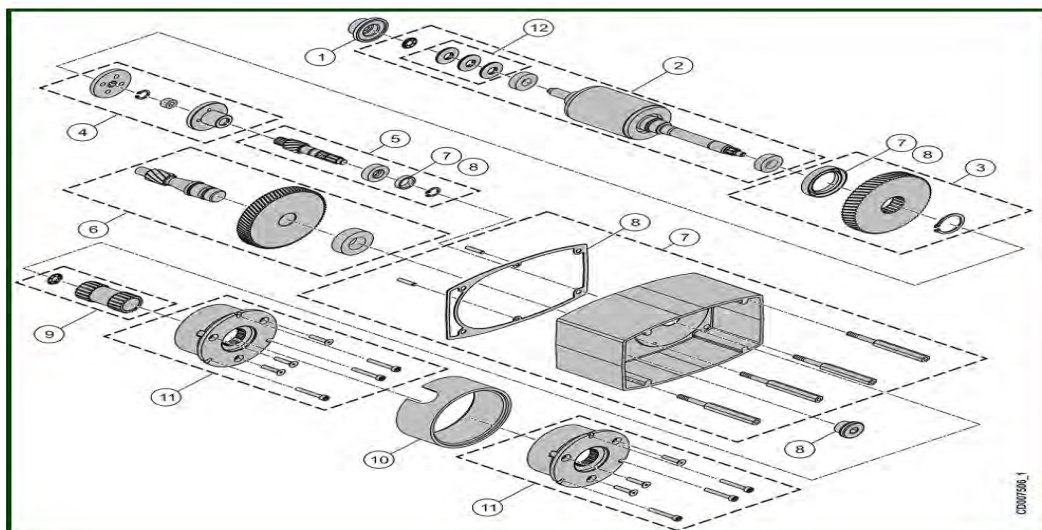

ITEM	REFERENCE	DESCRIPTION
1	VT0007214	Clutch adjusting screw
2	VT0007221	Rotor module
3	VT0007231	Gear set - 1st step
4	VT0007232	Friction disc + Clutch set
5	VT0007233	Set gear shaft
6	VT0007222	Gear
7	VT0007175	Frame - Gear side Double brakes
8	VT0007234	Set sealing
9	VT0007235	Set brake hub Double brakes
10	VT0007237	Ring
11	VT0007239	Set brake 103V-230V
11	VT0007593	Set brake 190V-400V
12	VT0007238	Set Belleville washer

4) ELECTRICAL PARTS

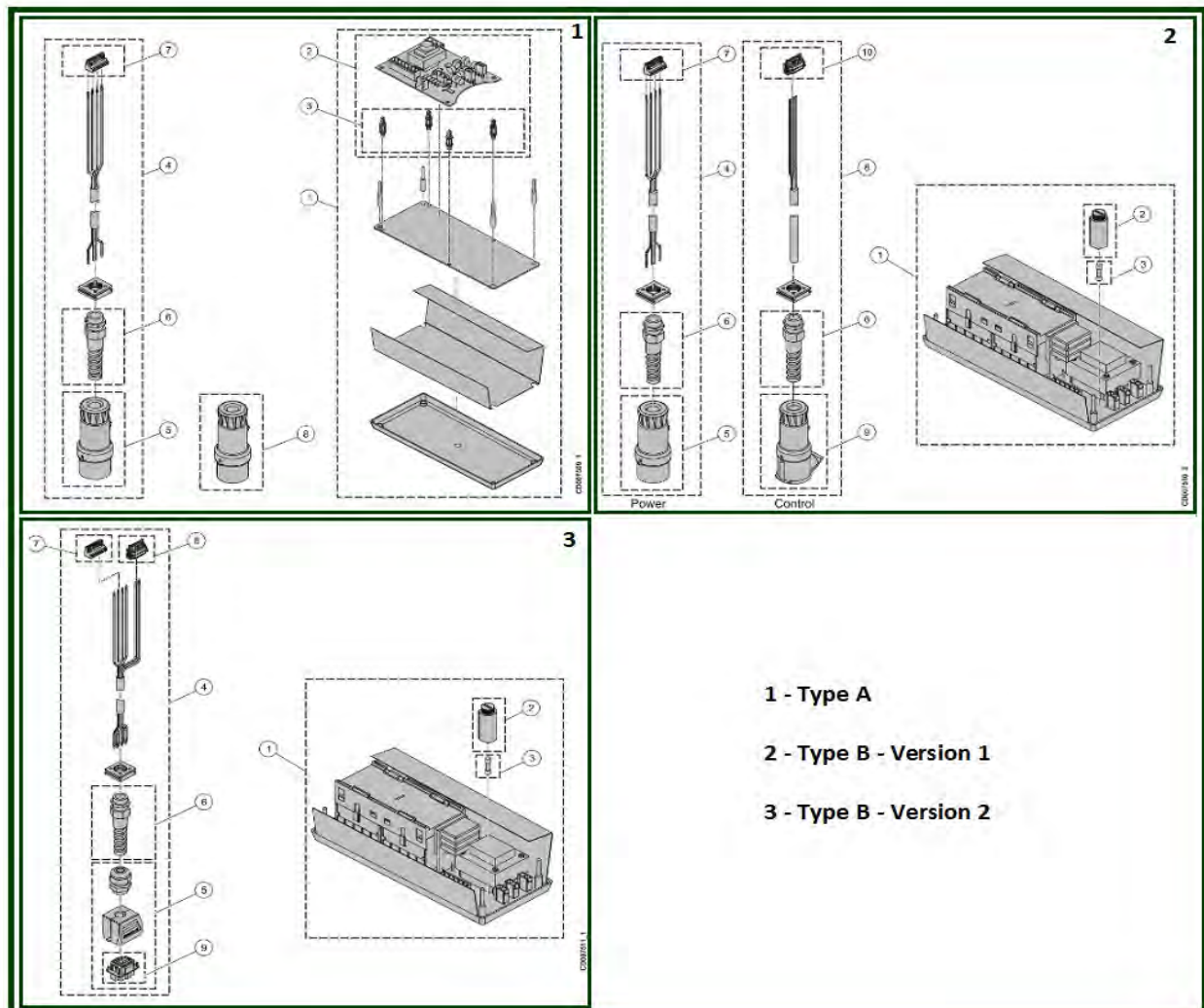

4.1) VERSION A

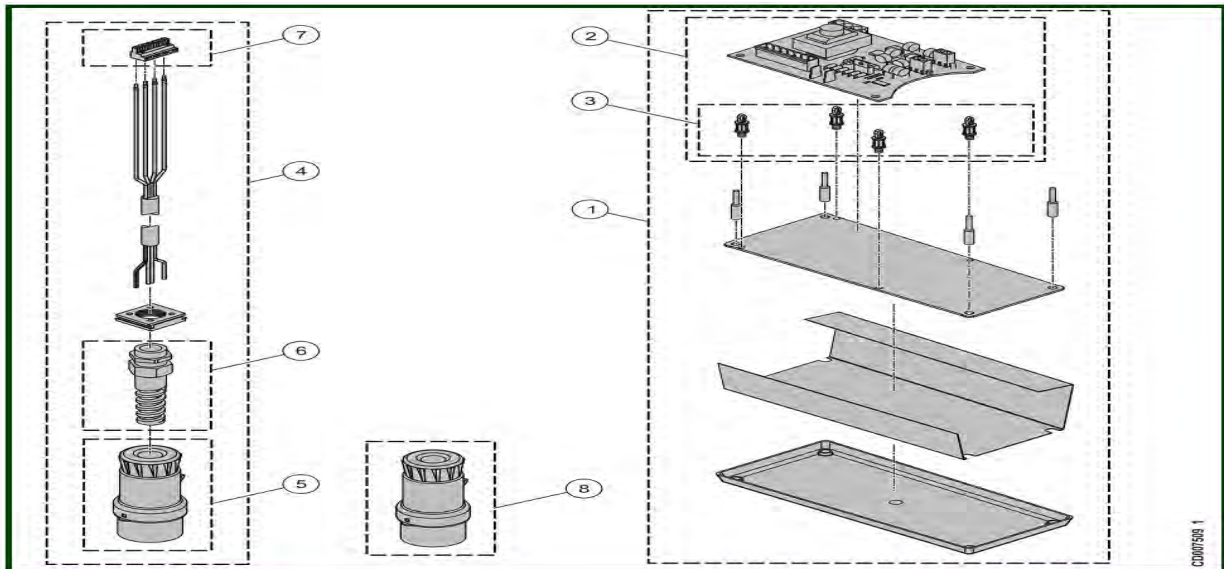

ITEM	REFERENCE	DESCRIPTION
1	VT0007209	CI Board 208V-600V / 50 60Hz
2	VT0007241	CI board set 208-600V / 50 60Hz
3	VT0007242	PC board support
4	VT0006078	Power supply male blue plug/cable 230V / 50-60Hz / 3P+T 0,5m
4	VT0006076	Power male red plug/cable 380-415V/50-60Hz-400V3P+T 0,5m
5	VT0006087	Power supply male blue plug 230V / 3P+T
5	VT0006086	Power supply male red plug 400V / 3P+T
6	VT0006399	Spiral cable gland
7	VT0005107	Power connector 4P
8	VT0006085	Female blue plug 230V / 3P+T
8	VT0006001	Female red plug 400V / 3P+T

4.2) VERSION B WITH CE PLUG

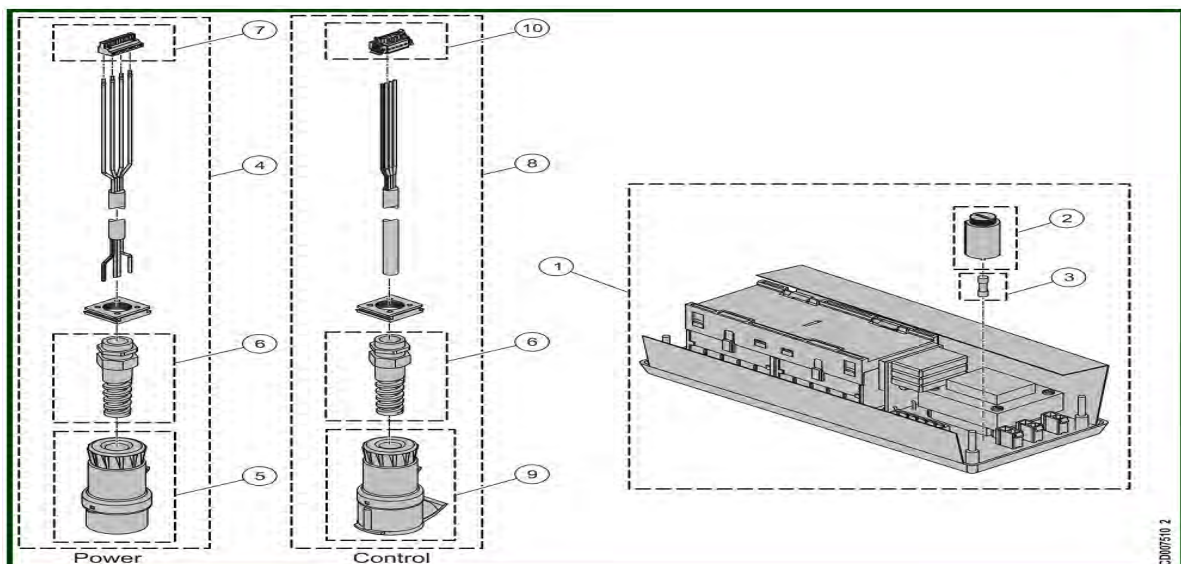

ITEM	REFERENCE	DESCRIPTION
1	VT0007210	CI Board 208V-230V/115V 50/60Hz
1	VT0007211	CI Board 380V-415V/48V 50/60Hz
1	VT0007212	CI Board 440V-480V/48V 50/60Hz
1	VT0007213	CI Board 440V-480V/115V 50/60Hz
2	VT0006191	Fuses base
3	VT0007595	Set of 10 fuses 50mA - 115V
3	VT0007594	Set of 10 fuses 125mA - 48V
4	VT0006078	Power supply male blue plug/cable 230V/50-60Hz / 3P+T 0.5m
4	VT0006076	Power male red plug/cable 380-415V/50-60Hz-400V-3P+T 0.5m
5	VT0006087	Power supply male blue plug 230V / 3P+T
5	VT0006086	Power supply male red plug 400V / 3P+T
6	VT0006399	Spiral cable gland
7	VT0005107	Power connector 4P
8	VT0006409	Control yellow plug with cable
9	VT0006761	Control yellow plug – Female 115V - 3P+T
10	VT0007585	Control connector Only for US
10	VT0006412	Control connector - 5 P
11	VT0006411	Control adapter 24V-230V
12	VT0006410	Power adapter 208V-600V

4.3) VERSION B WITH HARTING PLUG

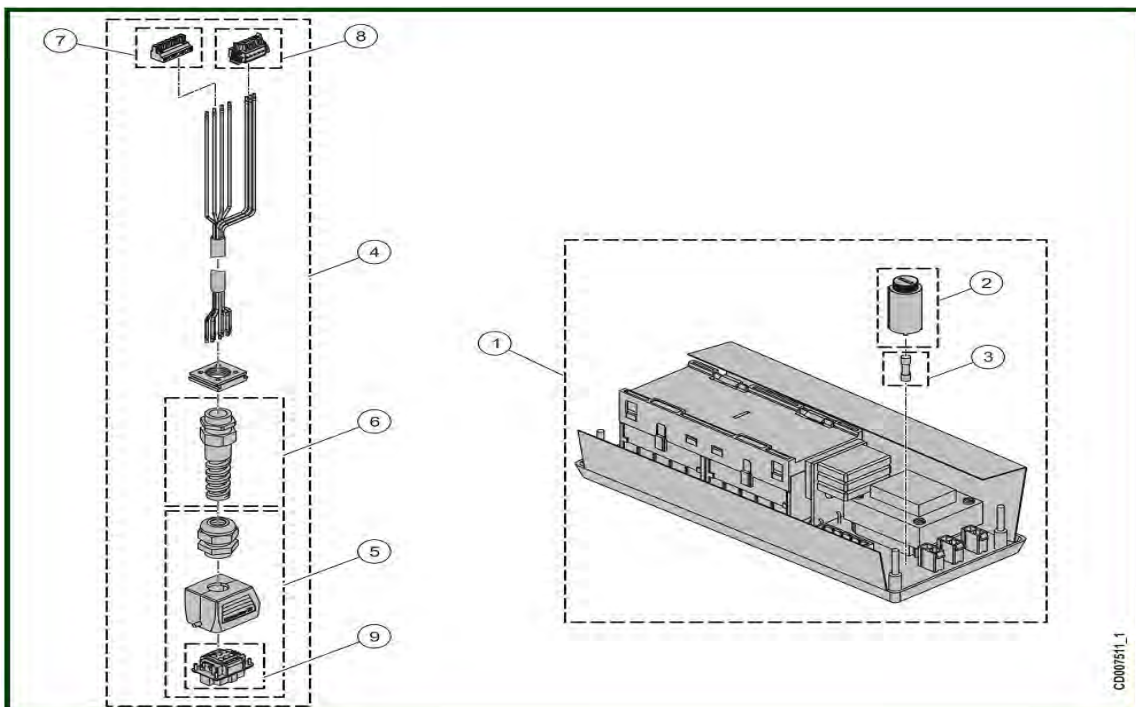

ITEM	REFERENCE	DESCRIPTION
1	VT0007210	CI Board 208V-230V/115V 50/60Hz
1	VT0007211	CI Board 380V-415V/48V 50/60Hz
1	VT0007212	CI Board 440V-480V/48V 50/60Hz
1	VT0007213	CI Board 440V-480V/115V 50/60Hz
2	VT0006191	Fuses base
3	VT0007595	Set of 10 fuses 50mA - 115V
3	VT0007594	Set of 10 fuses 25mA - 48V
4	VT0007243	Harting plug + cable set 6P+G
5	VT0007247	Harting plug
6	VT0006399	Spiral cable gland
7	VT0005107	Power connector 4P
8	VT0006412	Control connector - 5 P
9	VT0007244	Female Insert
10	VT0006411	Control adapter 24V-230V
11	VT0006410	Power adapter 208V-600V