

SPARE PARTS CATALOGUE FOR SR10

To avoid errors, when ordering please specify:

- Complete type of hoist
- Date of manufacture and serial number
- Spare part code
- Spare part designation
- Additional information



1) FRAME

1.1) Rotary hook

1.2) Fixed hook

2) CHAIN GUIDE – 7X20

2.1) A version - 1 fall

2.2) A version - 2 fall

2.3) B version - 1 fall Gear limit switch & Magnetic

2.4) B version - 2 fall Gear limit switch & Magnetic

3) GEAR

3.1) Simple brake

3.2) Double brake

4) MOTOR

4.1) Single brake

4.2) Double brake

5) ELECTRICAL PARTS

5.1) Version A

5.2) Version B

1) FRAME

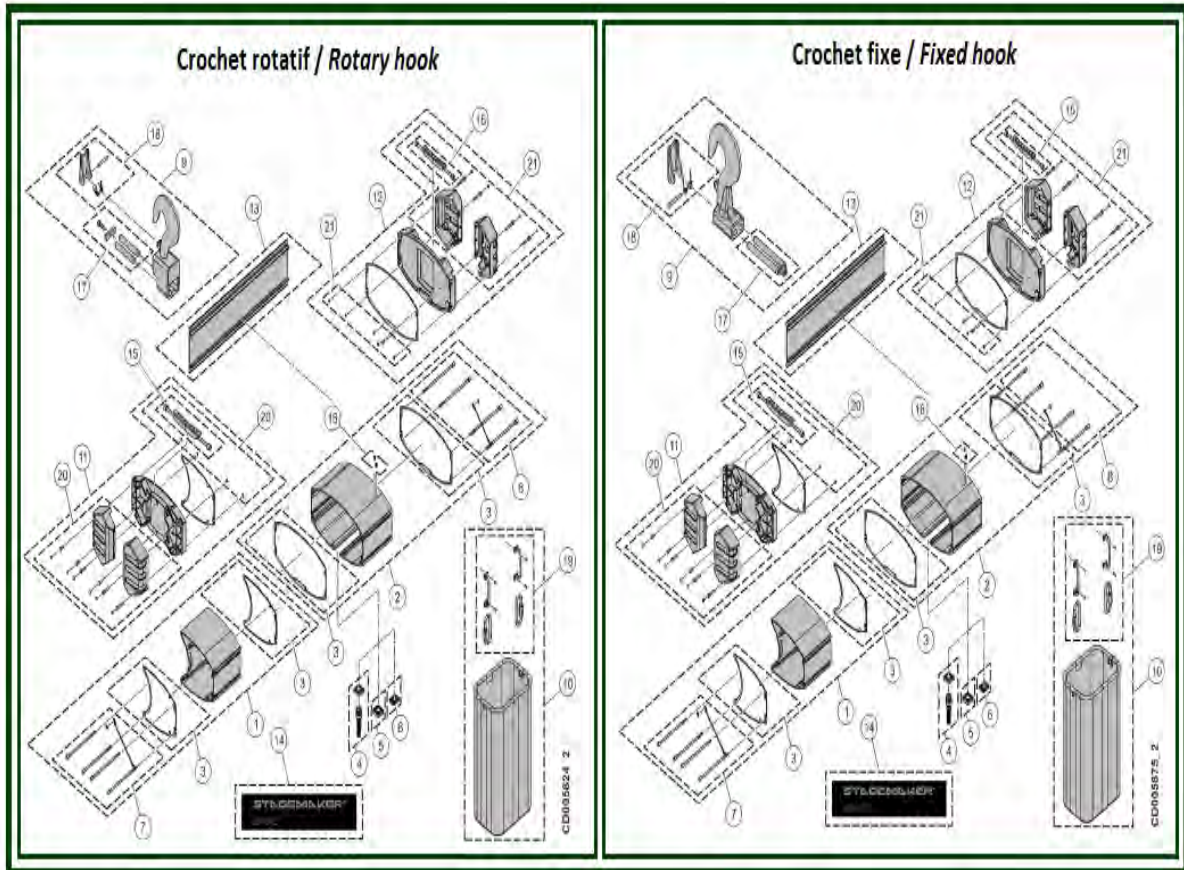

1.1) ROTARY HOOK

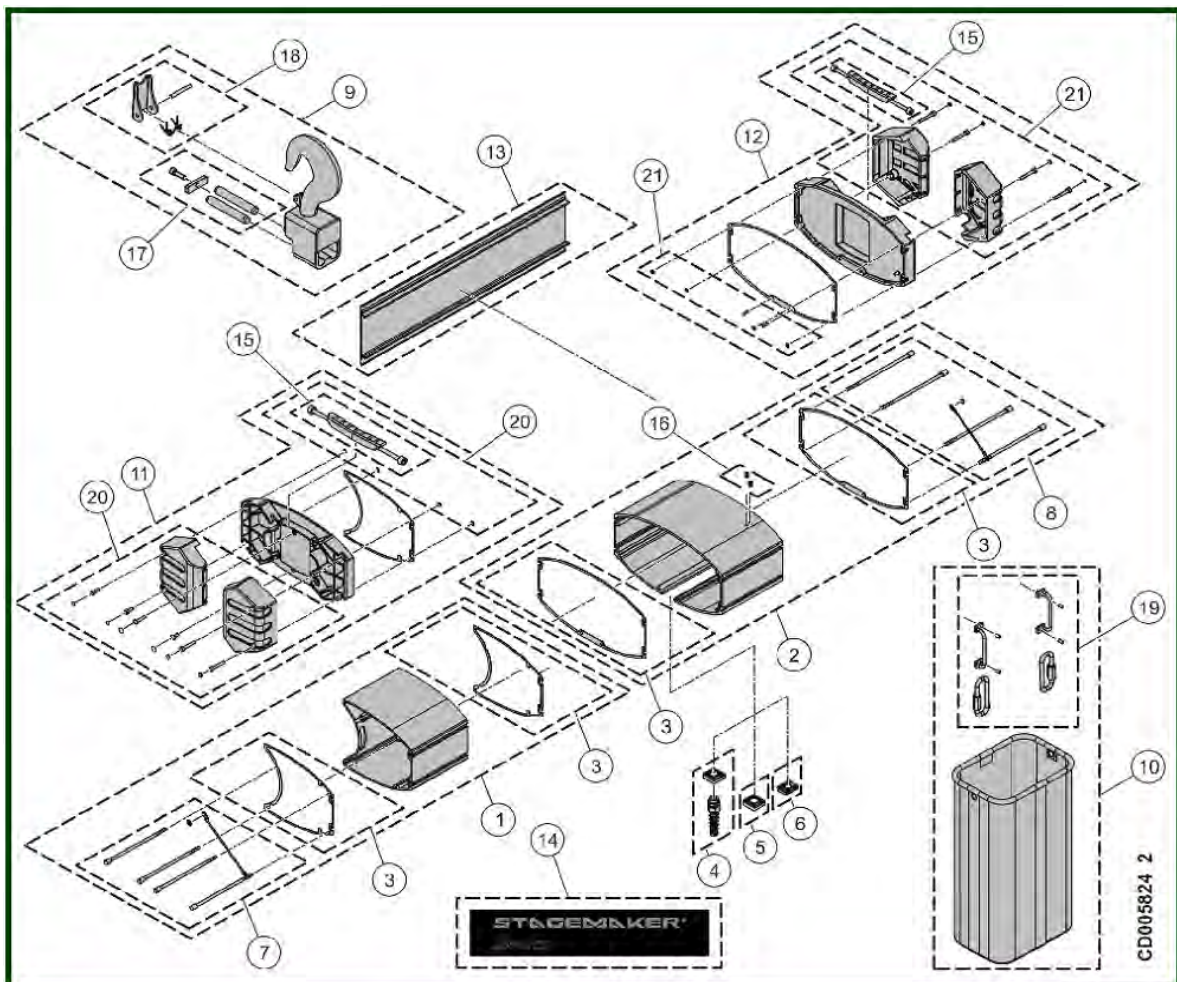

ITEM	REFERENCE	DESCRIPTION
1	VT0006946	Housing set - Motor side
2	VT0006948	Housing set Brake side Double brake + Geared limit switch
2	VT0006947	Housing set Brake side Single brake + Geared limit switch
3	VT0006949	Seal set
4	VT0007033	Cable gland set with square cable entry PE ISO 25
5	VT0007034	End cap - Square cable entry PE ISO 25
6	VT0006384	End cap + Long set
7	VT0006911	Screw set M6L165 - Motor side
8	VT0006912	Screw set M6L180 - Brake side Single brake
8	VT0006936	Screw set M6L217 - Brake side Double brake
9	VT0006361	Rotating upper hook
9	VT0005561	Upper hook
10	VT0006360	Chain bucket 20 m
10	VT0007023	Chain bucket 50 m
11	VT0006385	Cover set - Motor side
12	VT0006386	Cover set - Brake side
13	VT0006367	Cover set Double brakes
13	VT0006366	Housing Double brakes
14	VT0006365	Sticker – Brand Double brakes
14	VT0006364	Sticker – Brand Single brake
15	VT0006030	Set of 2 rubber handles Single/Double Brake
16	VT0006084	Set of 4 plug set
17	VT0005562	Shaft set
18	VT0005903	Safety latch Rotary hook-1 fall
19	VT0006036	Fixing set of chain bucket 20 m - Reverse
20	VT0006523	Rubber set - Motor side
21	VT0006524	Rubber set - Brake side
22	VT0006048	Set of 10 load plates – Hoist 500 kg
22	VT0006050	Set of 10 load plates – Hoist 1000 Kg
22	VT0006053	Set of 10 load plates – Hoist 2000 Kg
23	VT0006026	Identification plate – Motor Serial number required
24	VT0006945	Canvas rain cover

1.2) FIXED HOOK

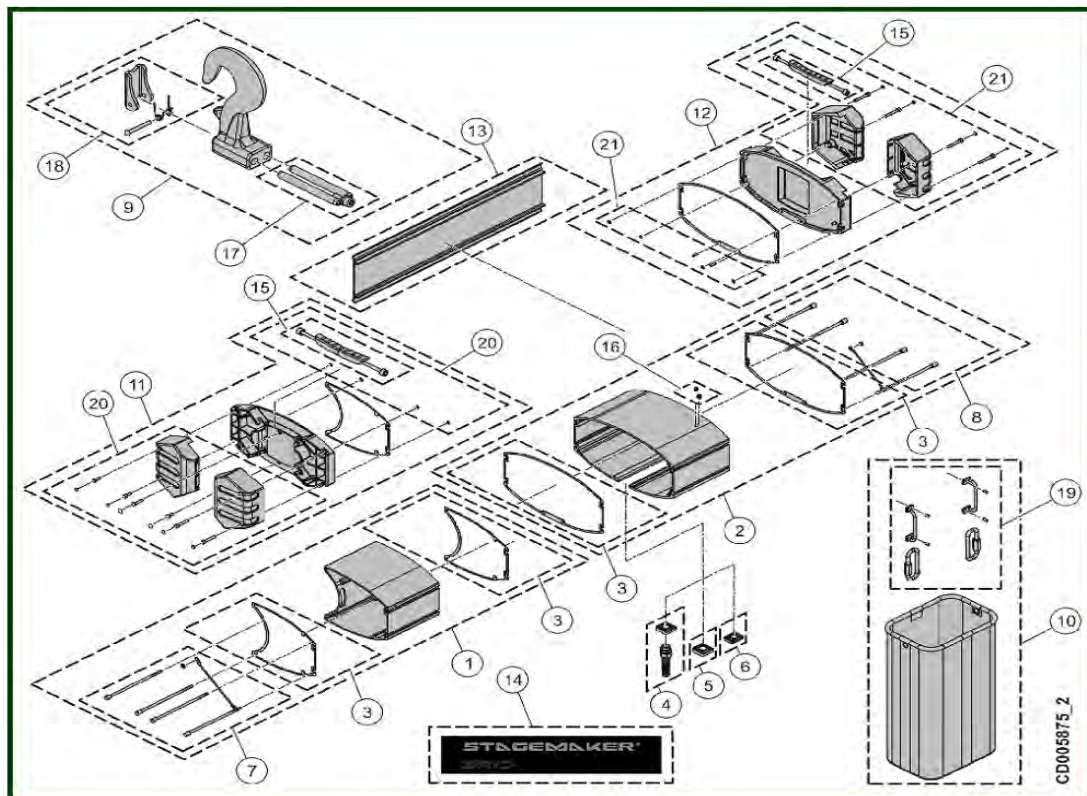

ITEM	REFERENCE	DESCRIPTION
1	VT0006946	Housing set - Motor side
2	VT0006948	Housing set Brake side Double brake + Geared limit switch
2	VT0006947	Housing set Brake side Single brake + Geared limit switch
3	VT0006949	Seal set
4	VT0007033	Cable gland set with square cable entry PE ISO 25
5	VT0007034	End cap - Square cable entry PE ISO 25
6	VT0006384	End cap + Long set
7	VT0006911	Screw set M6L165 - Motor side
8	VT0006912	Screw set M6L180 – Single Brake side
8	VT0006936	Screw set M6L217 – Double Brake side
9	VT0005561	Upper hook
10	VT0006360	Chain bucket 20 m
10	VT0007023	Chain bucket 50 m
11	VT0006385	Cover set - Motor side
12	VT0006386	Cover set - Brake side
13	VT0006367	Cover set Double brake
13	VT0006366	Housing Double brakes

14	VT0006365	Sticker – Brand Double brake
14	VT0006364	Sticker – Brand Single brake
15	VT0006030	Set of 2 rubber handles Single/Double Brake
16	VT0006084	Set of 4 plug set
17	VT0005562	Shaft set
18	VT0005902	Safety latch
18	VT0005903	Safety latch Rotary hook-1 fall
19	VT0006036	Fixing set of chain bucket 20 m - Reverse
20	VT0006523	Rubber set - Motor side
21	VT0006524	Rubber set - Brake side
22	VT0006048	Set of 10 load plates – Hoist 500 kg
22	VT0006050	Set of 10 load plates – Hoist 1000 Kg
22	VT0006053	Set of 10 load plates – Hoist 2000 Kg
23	VT0006026	Identification plate – Motor Serial number request
24	VT0006945	Canvas rain cover

2) CHAIN GUIDE – 7X20

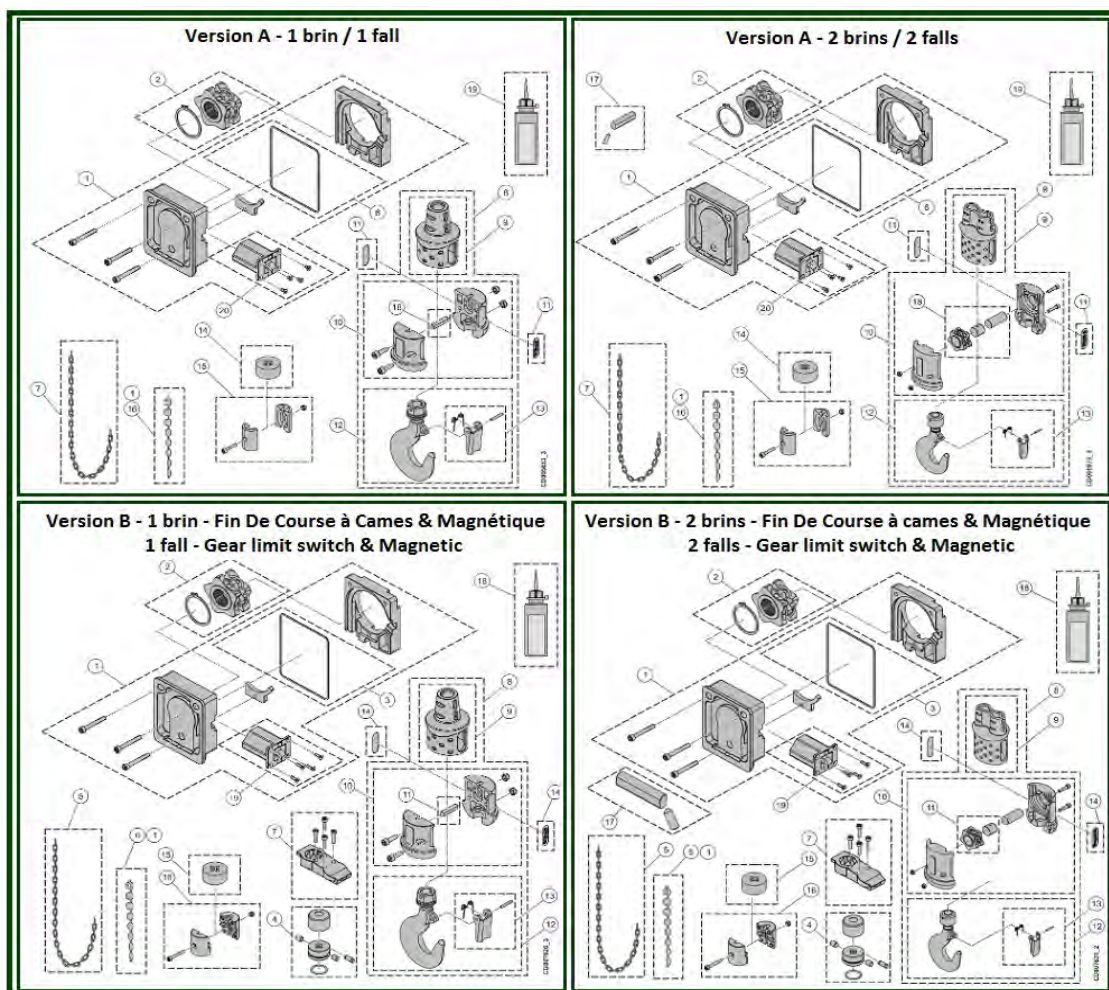

2.1) VERSION A - 1 FALL

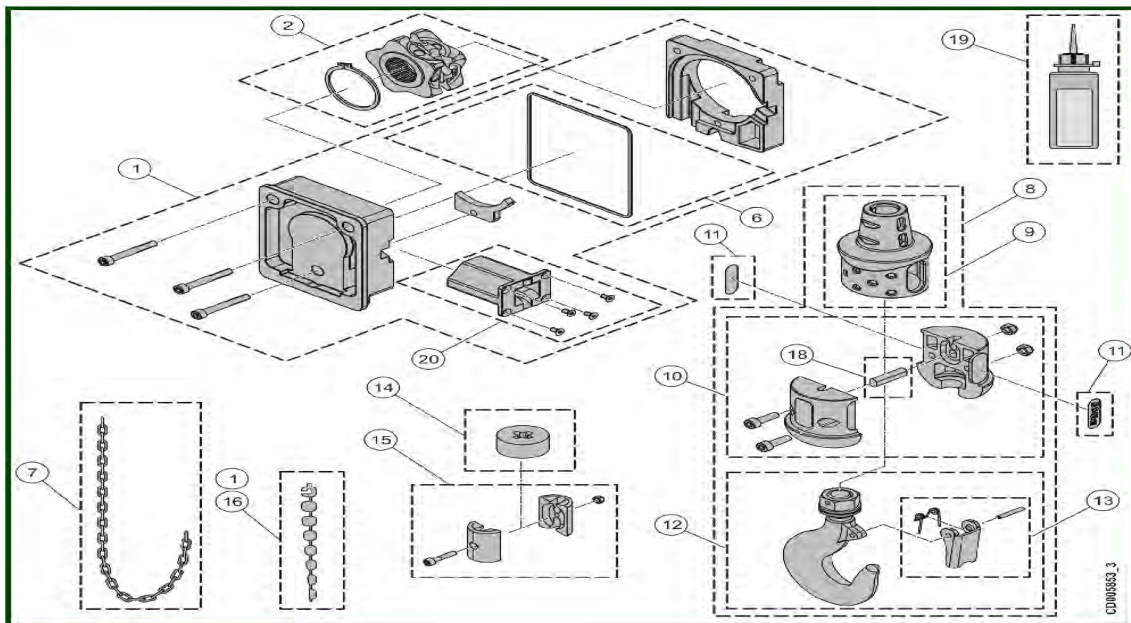

ITEM	REFERENCE	DESCRIPTION
1	VT0006387	Chain guide - Chain 7x20
2	VT0005851	Chain sprocket
6	VT0006368	Seal set
7	VT0006369	Black chain 7x20
8	VT0006370	Hook block 1 fall
9	VT0005855	Rubber chain stop
10	VT0006391	Hook component / 1 fall
11	VT0006388	Set of 10 load plates – Hoist 500 kg
11	VT0006389	Set of 10 load plates – Hoist 1000 kg
11	VT0006390	Set of 10 load plates – Hoist 2000 kg
12	VT0006372	Hook assembly 1 fall
13	VT0005903	Safety latch Rotary hook-1 fall
14	VT0008134	Rubber chain stop D40 T15 Replace old model rubber
14	VT0005863	Rubber chain stop-Old model 2 fall
15	VT0005864	Chain stop 2 falls Never use as chain stop side hook
16	VT0005575	Chain fitting tool
18	VT0006371	Pin 1 fall
18	VT0005882	Return sprocket 2 falls
19	VT0006025	Oil can
20	VT0008561	External chain guide

2.2) VERSION A - 2 FALL

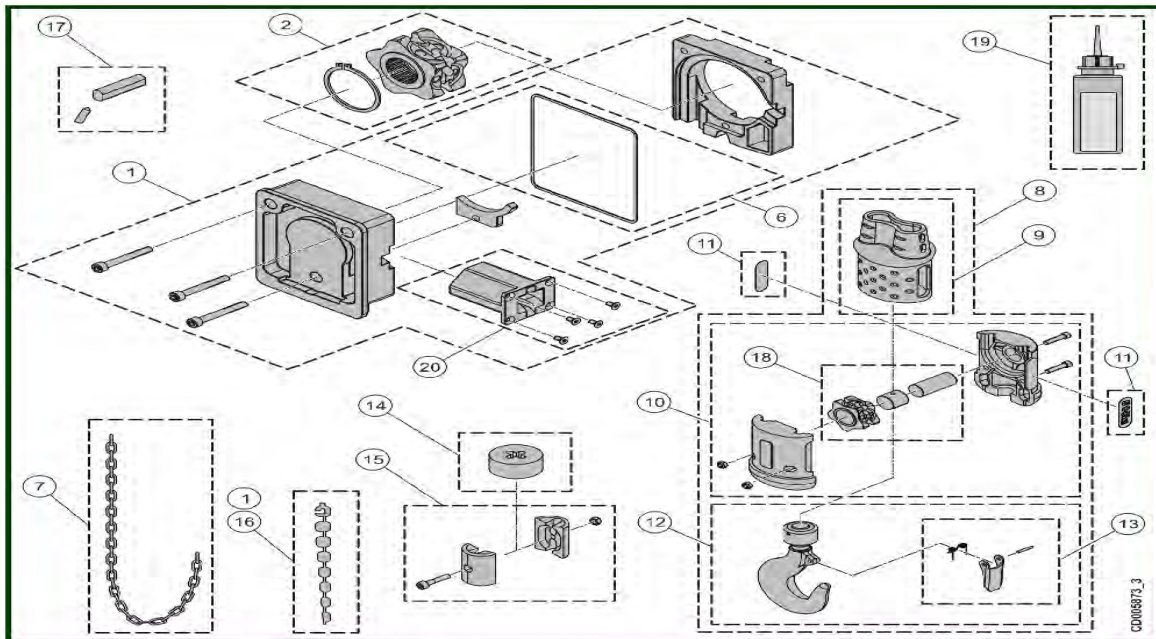

ITEM	REFERENCE	DESCRIPTION
1	VT0006387	Chain guide - Chain 7x20
2	VT0005851	Chain sprocket
6	VT0006368	Seal set
7	VT0006369	Black chain 7x20
8	VT0006373	Hook block 2 falls
9	VT0005868	Rubber chain stop 2 falls
10	VT0006392	Hook component 2 falls
11	VT0006388	Set of 10 load plates – Hoist 500 kg
11	VT0006389	Set of 10 load plates – Hoist 1000 kg
11	VT0006390	Set of 10 load plates – Hoist 2000 kg
12	VT0006374	STD hook assembly RSN08-7021 SR10 2 fall SR25 1 fall
13	VT0005902	Safety latch
14	VT0008134	Rubber chain stop D40 T15 Replace old model rubber
14	VT0005863	Rubber chain stop-Old model 2 fall
15	VT0005864	Chain stop - 2 falls Never use as chain stop side hook
16	VT0005575	Chain fitting tool
17	VT0006376	Fixing stop 2 falls
18	VT0005882	Return sprocket 2 falls
19	VT0006025	Oil can
20	VT0008561	External chain guide

2.3) VERSION B - 1 FALL GEAR LIMIT SWITCH & MAGNETIC

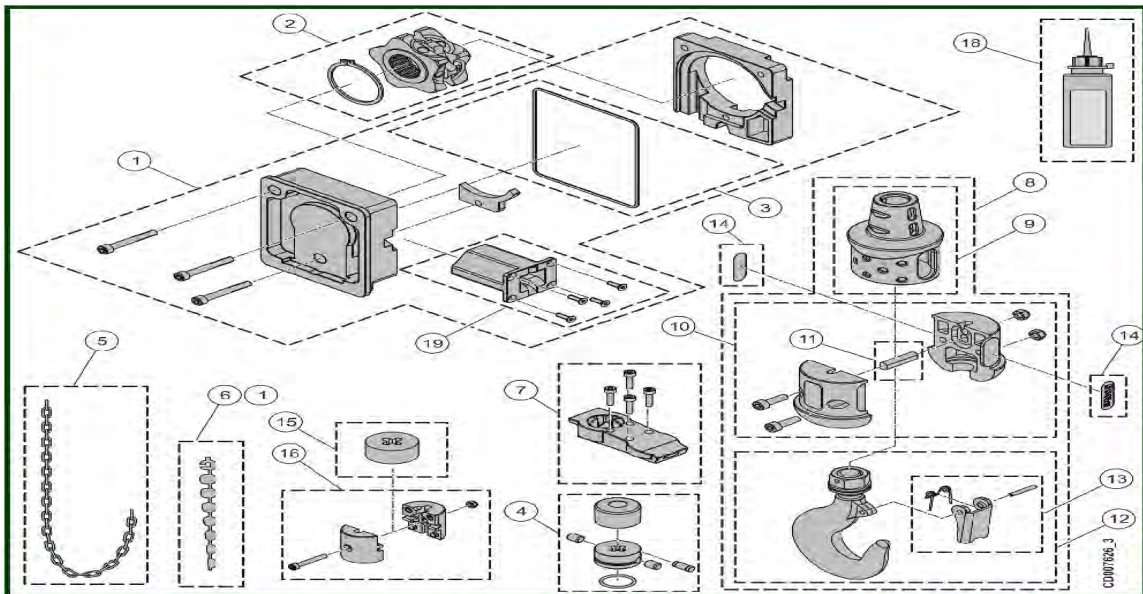

ITEM	REFERENCE	DESCRIPTION
1	VT0006387	Chain guide - Chain 7x20
2	VT0005851	Chain sprocket
3	VT0006368	Seal set
4	VT0007404	Limit switch activator
5	VT0006369	Black chain 7x20
6	VT0005575	Chain fitting tool
7	VT0007406	Set of chain entry
8	VT0006370	Hook block 1 fall
9	VT0005855	Rubber chain stop
10	VT0006391	Hook component 1 fall
11	VT0006371	Pin 1 fall
12	VT0006372	Hook assembly 1 fall
13	VT0005903	Safety latch Rotary hook-1 fall
14	VT0006388	Set of 10 load plates – Hoist 500 kg
14	VT0006389	Set of 10 load plates – Hoist 1000 kg
14	VT0006390	Set of 10 load plates – Hoist 2000 kg
15	VT0008134	Rubber chain stop D40 T15 Replace old model rubber
15	VT0005863	Rubber chain stop-Old model 2 falls
16	VT0007405	Slack fall stop
18	VT0006025	Oil can
19	VT0008561	External chain guide

2.4) B VERSION - 2 FALL - GEAR LIMIT SWITCH & MAGNETIC

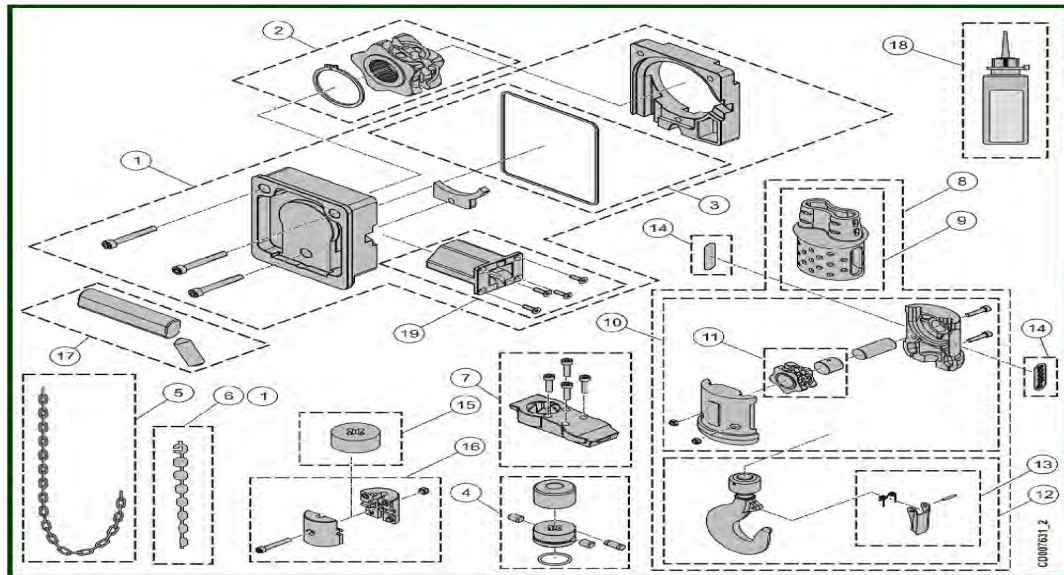

ITEM	REFERENCE	DESCRIPTION
1	VT0006387	Chain guide - Chain 7x20
2	VT0005851	Chain sprocket
3	VT0006368	Sea set
4	VT0007404	Limit switch activator
5	VT0006369	Black chain 7x20
6	VT0005575	Chain fitting tool
7	VT0007406	Set of chain entry
8	VT0006373	Hook block 2 fall
9	VT0005868	Rubber chain stop 2 fall
10	VT0006392	Hook component 2 fall
11	VT0005882	Return sprocket 2 fall
12	VT0006374	Standard hook assembly RSN08-7021 SR10 2 fall SR25 1 fall
13	VT0005902	Safety latch
14	VT0006388	Set of 10 load plates – Hoist 500 kg
14	VT0006389	Set of 10 load plates – Hoist 1000 kg
14	VT0006390	Set of 10 load plates – Hoist 2000 kg
15	VT0008134	Rubber chain stop D40 T15 Replace old model rubber
15	VT0005863	Rubber chain stop-Old model 2 fall
16	VT0007405	Slack fall stop
17	VT0006376	Fixing stop 2 fall
18	VT0006025	Oil can
19	VT0008561	External chain guide

3) GEAR

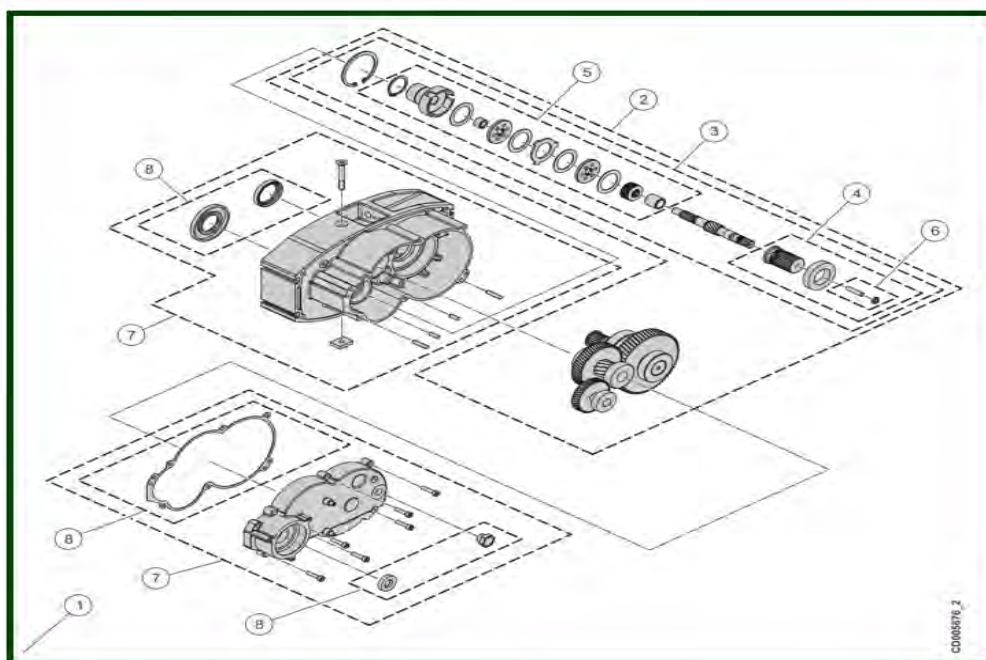

3.1) SIMPLE BRAKE

ITEM	REFERENCE	DESCRIPTION
1	VT0006394	Gear assembly - 4 & 8 n/min Single Brake
2	VT0006398	Gear / pinion set 8 m/min
3	VT0005896	Gear shaft & clutch 8m/min + 10m/min + 16m/min + 20m/min
4	VT0005897	Coupling - Side brake
5	VT0005894	Clutch
6	VT0005898	Screws set
7	VT0006375	Frame
8	VT0006527	Seal set
8	VT0006526	Seal set
10a	VT0006251	Gearwheel - Geared limit switch

3.2) DOUBLE BRAKE

ITEM	REFERENCE	DESCRIPTION
1	VT0006968	Gear assembly - 4 & 8 m/min – Double Brake
2	VT0006970	Gear / pinion set 8 m/min
3	VT0006969	Gear shaft/clutch 8 m/min + 10m /min + 16m /min + 20 m/min

4	VT0006525	Coupling - Side brake
5	VT0005894	Clutch
6	VT0005898	Screw set
7	VT0006375	Frame
8	VT0006527	Seal set
8	VT0006526	Seal set
10a	VT0006251	Gearwheel / Geared limit switch

4) MOTOR

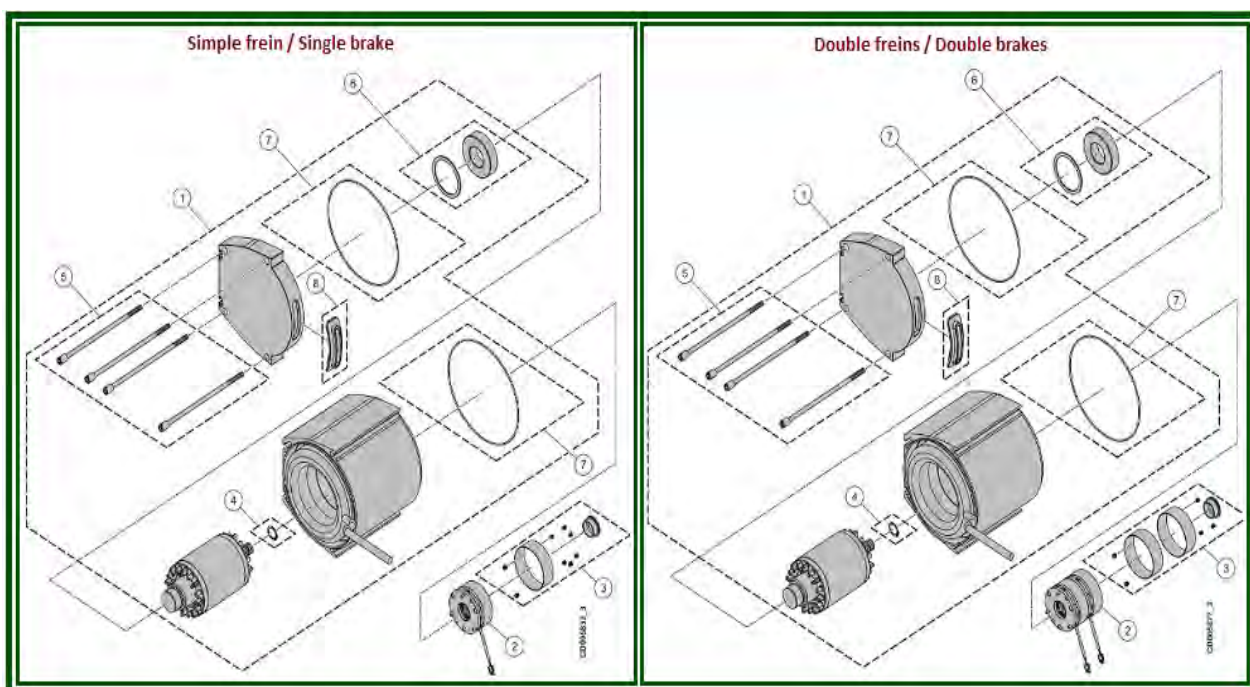

4.1) SINGLE BRAKE

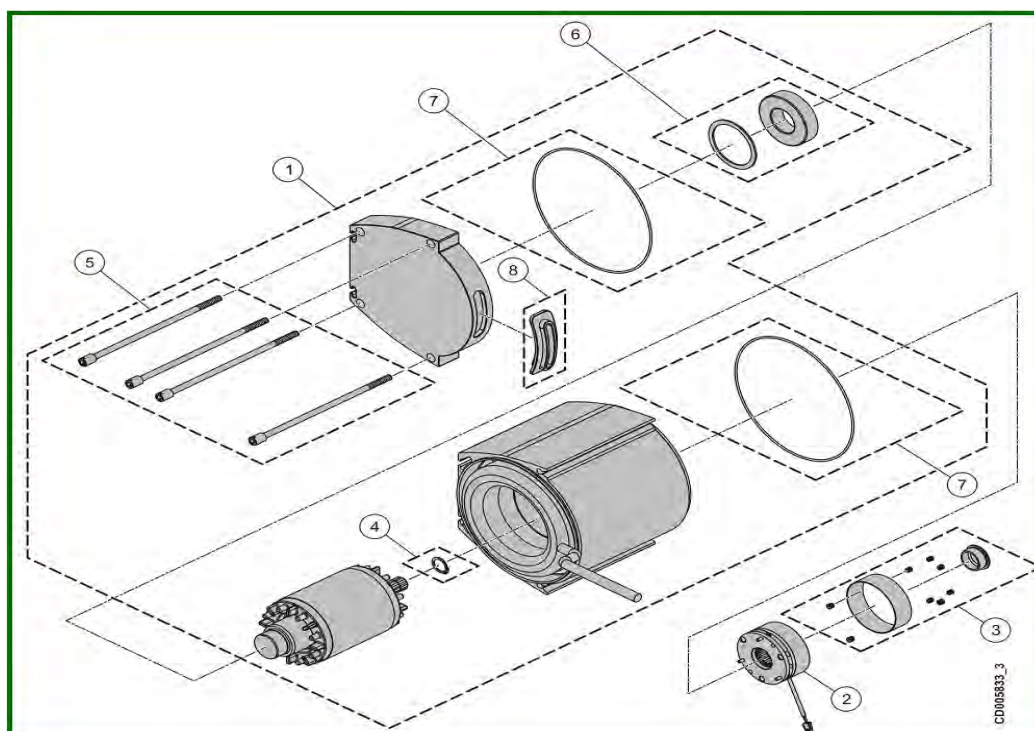

ITEM	REFERENCE	DESCRIPTION
1	VT0006381	Motor - 1 speed 220-240V - 50Hz - 1500
1	VT0006380	Motor - 1 speed 380-415V - 50Hz / 440-480 - 60Hz - 1500
1	VT0006378	Motor - 2 speed 220-240V - 50Hz - 3000
1	VT0006377	Motor - 2 speed 380-415V - 50Hz / 440-480V - 60Hz - 3000
2	VT0008037	Single brake 103V Since October 2015
2	VT0008038	Single brake 190V Since October 2015
3	VT0009215	Waterproof seal set for single brake
4	VT0005916	Retaining ring
5	VT0006530	Screw set
6	VT0006529	Bearing set
7	VT0006528	Seal set for motor
8	VT0009244	Grommet

4.2) DOUBLE BRAKE

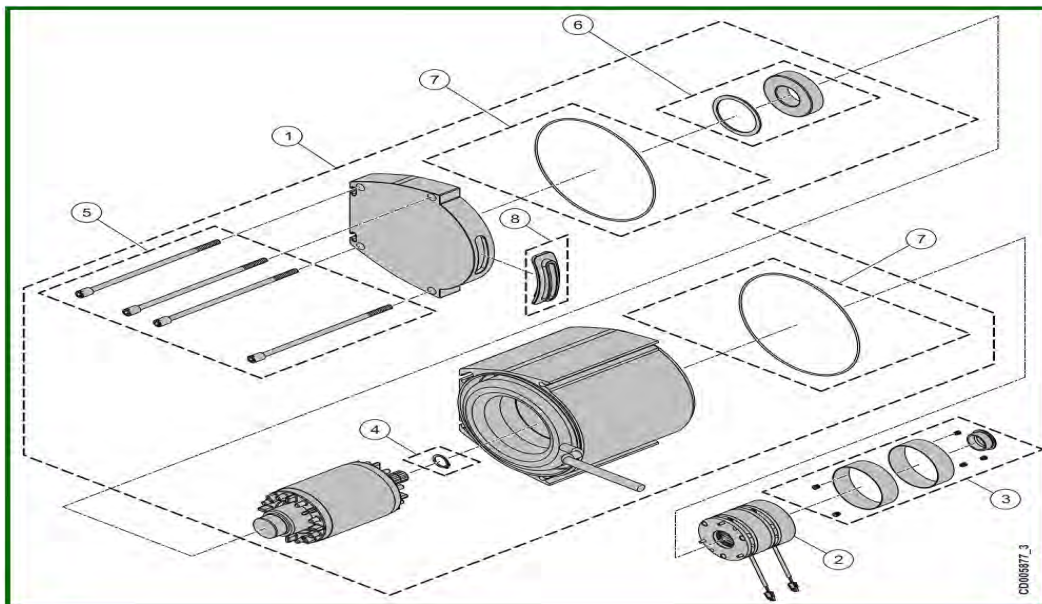

ITEM	REFERENCE	DESCRIPTION
1	VT0006381	Motor - 1 speed 220-240V - 50Hz - 1500
1	VT0006380	Motor - 1 speed 380-415V - 50Hz / 440-480 - 60Hz - 1500
1	VT0006378	Motor - 2 speed 220-240V - 50Hz – 3000
1	VT0006377	Motor - 2 speed 380-415V - 50Hz / 440-480V - 60Hz - 3000
2	VT0008039	Double brake 103 V - Since October 2015
2	VT0008040	Double brake 190 V - Since October 2015
3	VT0009216	Waterproof seal set for double brake

4	VT0005916	Retaining ring
5	VT0006530	Screw set
6	VT0006529	Bearing set
7	VT0006528	Seal set for motor
8	VT0009244	Grommet

5) ELECTRICAL PARTS

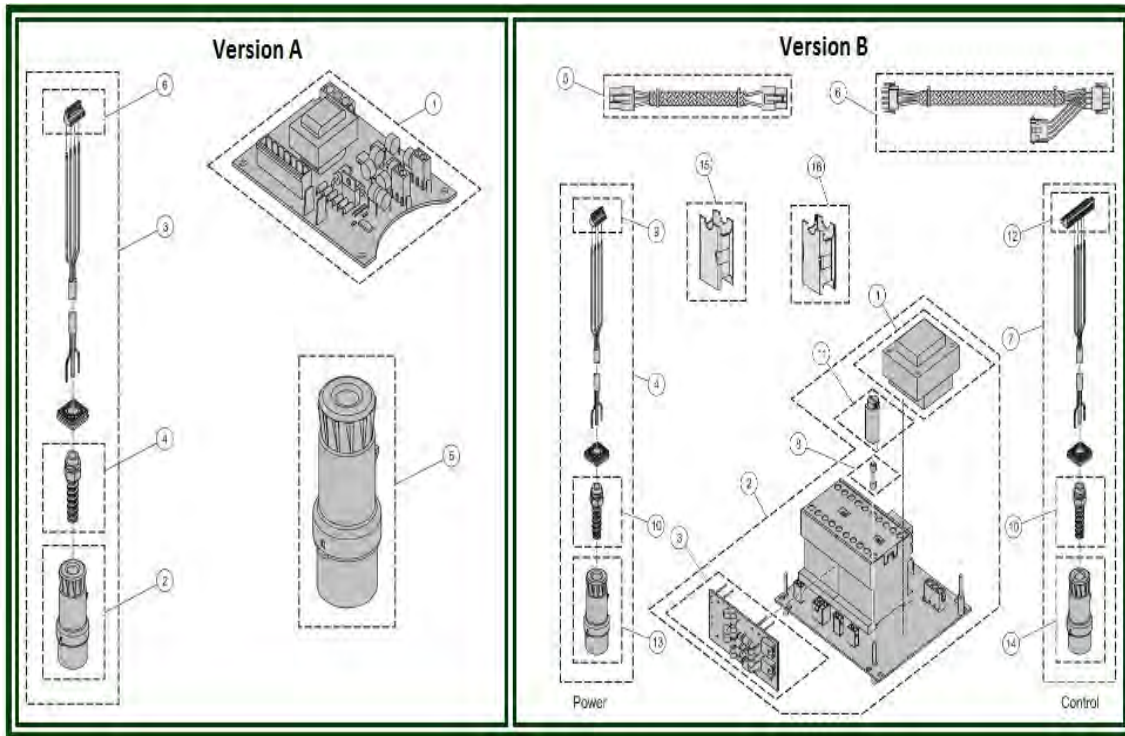

5.1) VERSION A

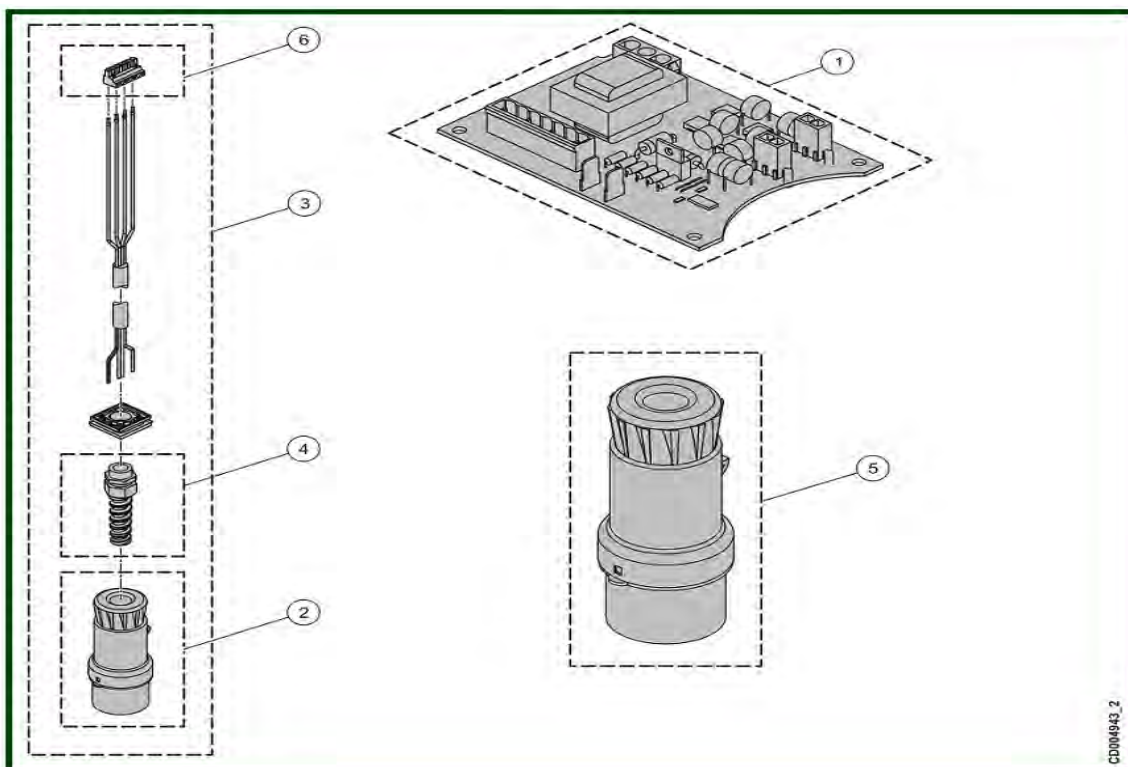

ITEM	REFERENCE	DESCRIPTION
1	VT0006000	ACF card 208-600V single speed
2	VT0006087	Power supply male blue plug 230V / 3P+T
2	VT0006086	Power supply male red plug 400V / 3P+T
3	VT0006078	Power supply male blue plug/cable 230V / 50-60Hz / 3P+T 0,5m
3	VT0006076	Power male red plug/cable 380-415V/50-60Hz-400V- 3P+T 0,5m
4	VT0006399	Spiral cable gland
5	VT0006085	Female blue plug 230V / 3P+T
5	VT0006001	Female red plug 400V / 3P+T
6	VT0005107	Power connector 4P

5.2) VERSION B

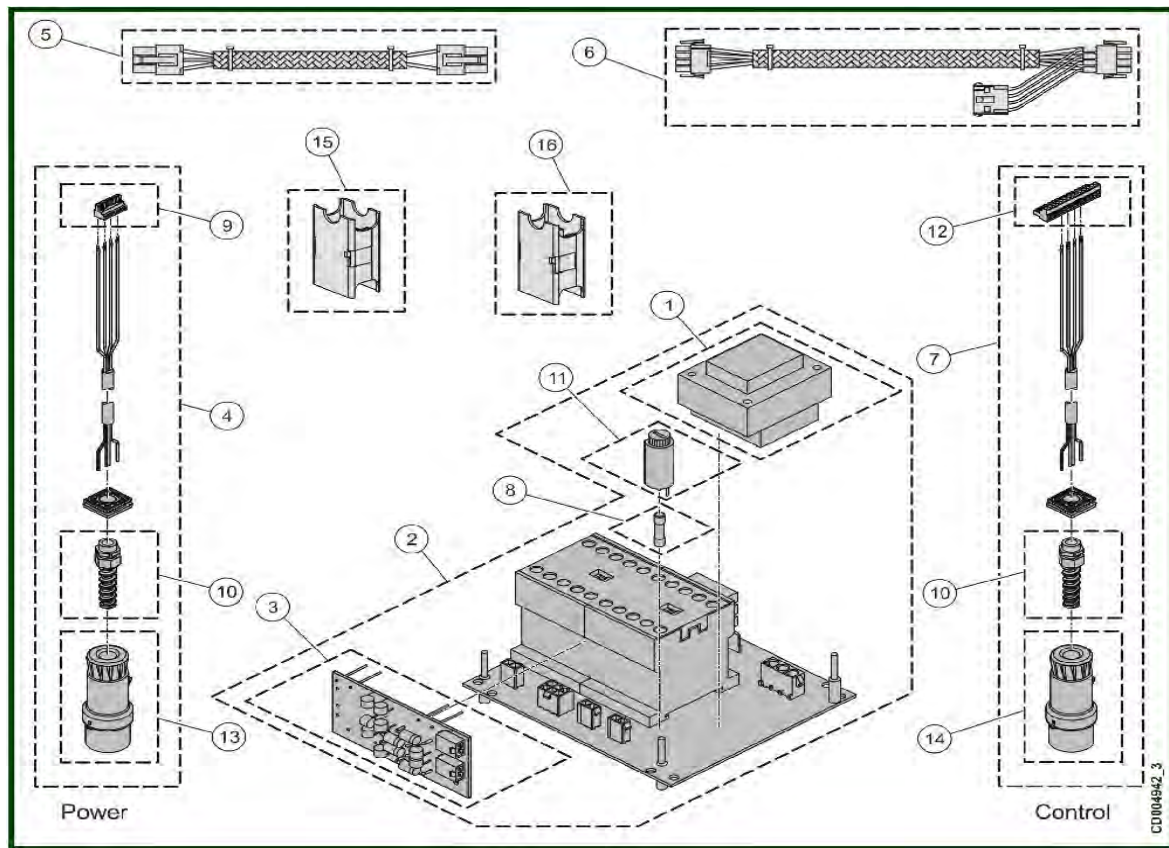

ITEM	REFERENCE	DESCRIPTION
1	VT0006193	Transformer 208V / 115V
1	VT0006407	Transformer 230V / 48V
1	VT0006408	Transformer 230V / 115V
1	VT0006192	Transformer 400V / 48V
1	VT0006406	Transformer 460V / 115V

2	VT0006097	Electrical board - 1 speed - 2 brakes 208V / 50-60HZ / 115V
2	VT0006404	Electrical board - 1 speed - 2 brakes 230V / 50HZ / 48V
2	VT0006405	Electrical board - 1 speed - 2 brakes 230V / 50HZ / 115V
2	VT0006099	Electrical board - 1 speed - 2 brakes 400V / 50HZ / 48V
2	VT0006098	Electrical board - 1 speed - 2 brakes 460V / 50-60HZ / 115V
3	VT0004947	Rectifier - 2 brakes 230V-690V
4	VT0006078	Power supply male blue plug/cable 230V/50-60Hz / 3P+T 0.5m
4	VT0006076	Power male red plug/cable 380-415V/50-60Hz-400V-3PT 0.5m
5	VT0004949	Wire harness - Plug control voltage
6	VT0004950	Wire harness - Plug power voltage
7	VT0006409	Control yellow plug with cable
8	VT0006194	Fuse set 48V
8	VT0006195	Fuse set 115V
9	VT0005107	Power connector 4P
10	VT0006399	Spiral cable gland
11	VT0006191	Fuse base
12	VT0006412	Control connector - 5 P
13	VT0006087	Power supply male blue plug 230V / 3P+T
13	VT0006086	Power supply male red plug 400V / 3P+T
14	VT0006761	Control yellow plug – Female 115V - 3P+T
15	VT0006410	Power adapter 208V-600V
16	VT0006411	Control adapter