

## SPARE PARTS CATALOGUE - SR5

To avoid errors, when ordering please specify:

- Complete type of hoist
- Date of manufacture and serial number
- Spare part code
- Spare part designation
- Additional information



### 1) FRAME

1.1) Rotary hook

1.2) Fixed hook

### 2) CHAIN GUIDE 5X14 + HOOKBLOCK

2.1) Inverted version

2.2) Industrial version

2.3) Magnetic limit switch

### 3) GEAR

3.1) 8 & 16 m/min - Standard limit switch & Magnetic

3.2) 8 & 16 m/min - Geared limit switch & Magnetic

### 4) MOTOR

4.1) Single brake

4.2) Double brakes

### 5) ELECTRICAL PARTS

5.1) Version A

5.2) Version B

# 1) FRAME

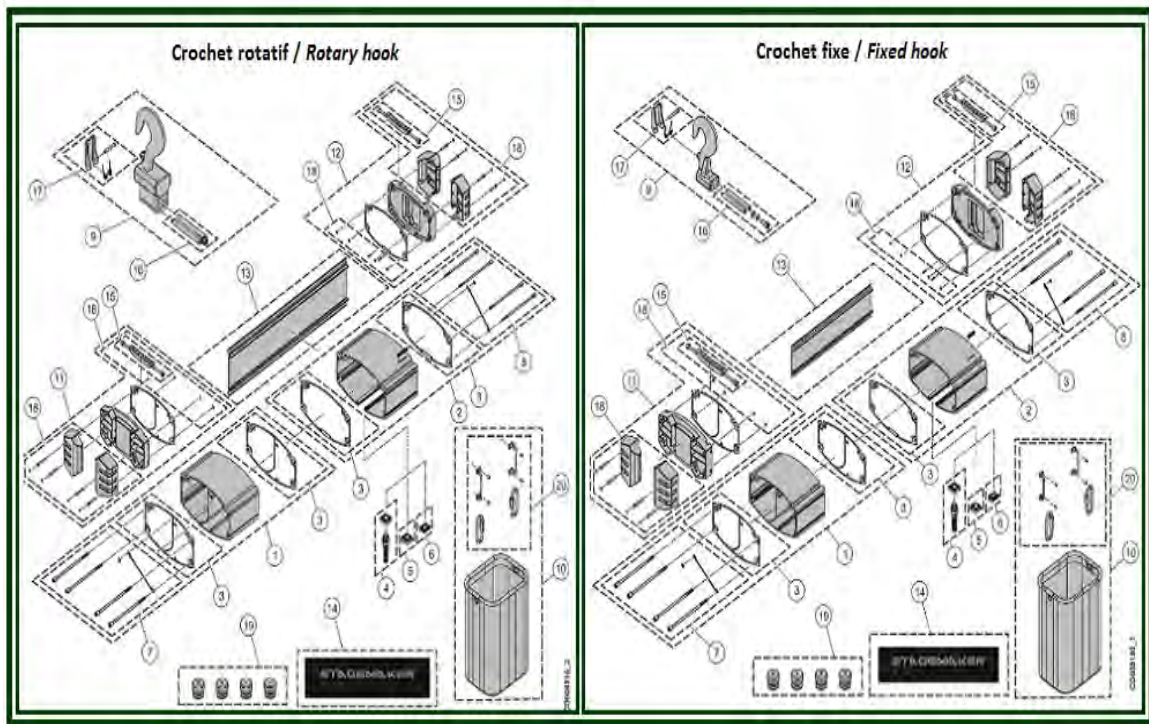

## 1.1) ROTARY HOOK

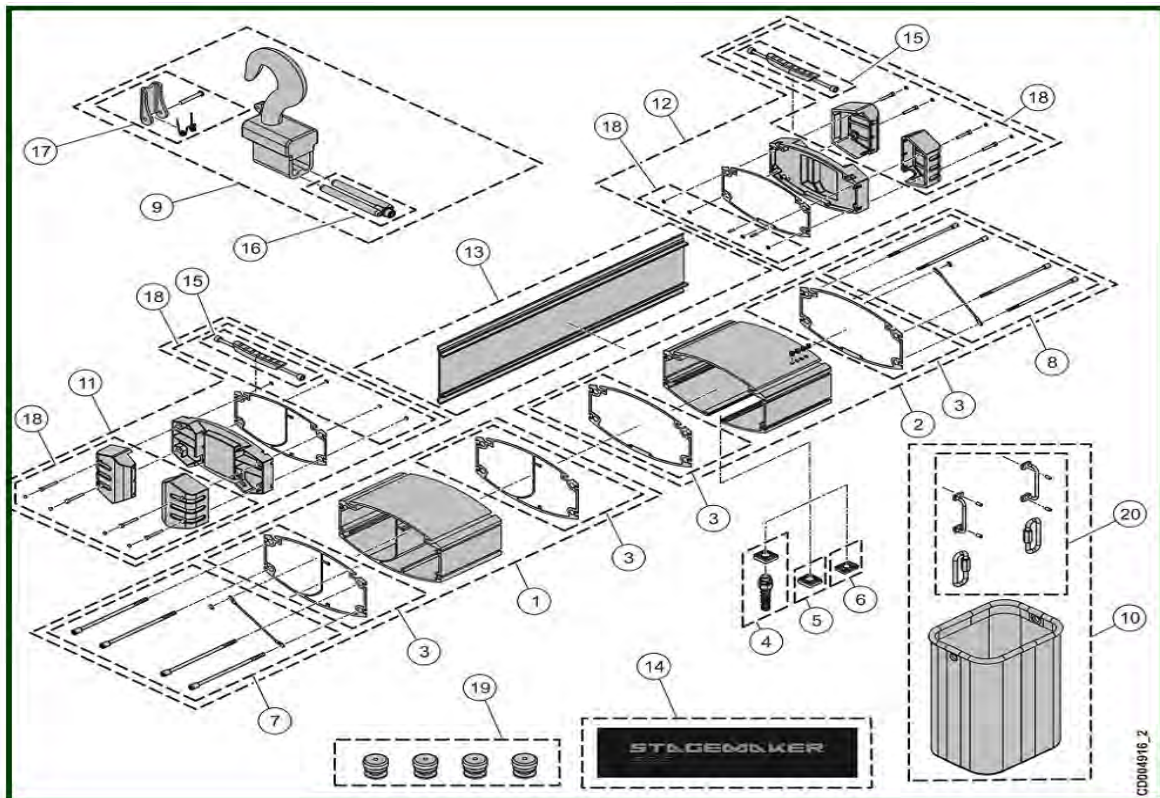

ITEM	REFERENCE	DESCRIPTION
1	VT0004555	Frame-Motor Standard Single & double brake/GLS Double brake
2	VT0007013	Housing set - Brake side GLS - 2 steps - Single brake
2	VT0007014	Housing set - Brake side GLS - 4 steps - Double brake

3	VT0004857	Seal set
4	VT0007033	Cable gland set with square cable entry PE ISO 25
5	VT0007034	End cap - Square cable entry PE ISO 25
6	VT0007035	End cap/rectangular cable entry PE ISO 25 Double brake FDC 4 step
7	VT0006328	Screw set M6L161-Motor side Standard + GLS Single/Double brake
8	VT0006327	Screw set M6L147 - Brake side Standard + GLS 2 steps Single brake
8	VT0007016	Screw set M6L180 - Brake side GLS Double brake
9	VT0006237	Rotating upper hook set
10	VT0007018	Chain bucket 20 m - Reverse
10	VT0006002	Chain bucket 30m for 5x14 - 50m for 4x11-Industrial/Normal
10	VT0007586	Chain bucket 40 m - Reverse
11	VT0006238	Cover set - Motor side
12	VT0006239	Cover set - Brake side (single/double brakes)
13	VT0006366	Housing Double brakes
13	VT0007019	Housing Single brake
14	VT0006038	Sticker – Brand Double brakes
14	VT0006007	Sticker– Brand Single brake
15	VT0006030	Set of 2 rubber handles (single/double brake)
16	VT0004862	Shaft set
17	VT0005901	Hook assembly Standard
18	VT0006035	Handle + Protection set
19	VT0006090	Set of 4 plug set
20	VT0006036	Fixing set of chain bucket 20 m - Reverse
20	VT0004860	Fixing set of chain bucket
-	VT0006091	Set of 10 load plates – Hoist 250 Kg
-	VT0006243	Set of 10 load plates – Hoist 500 kg
-	VT0006241	Set of 10 stickers load – Hoist 125 Kg
=	VT0006026	Identification plate – Motor Serial number required
=	VT0006944	Rain cover

## 1.2) FIXED HOOK

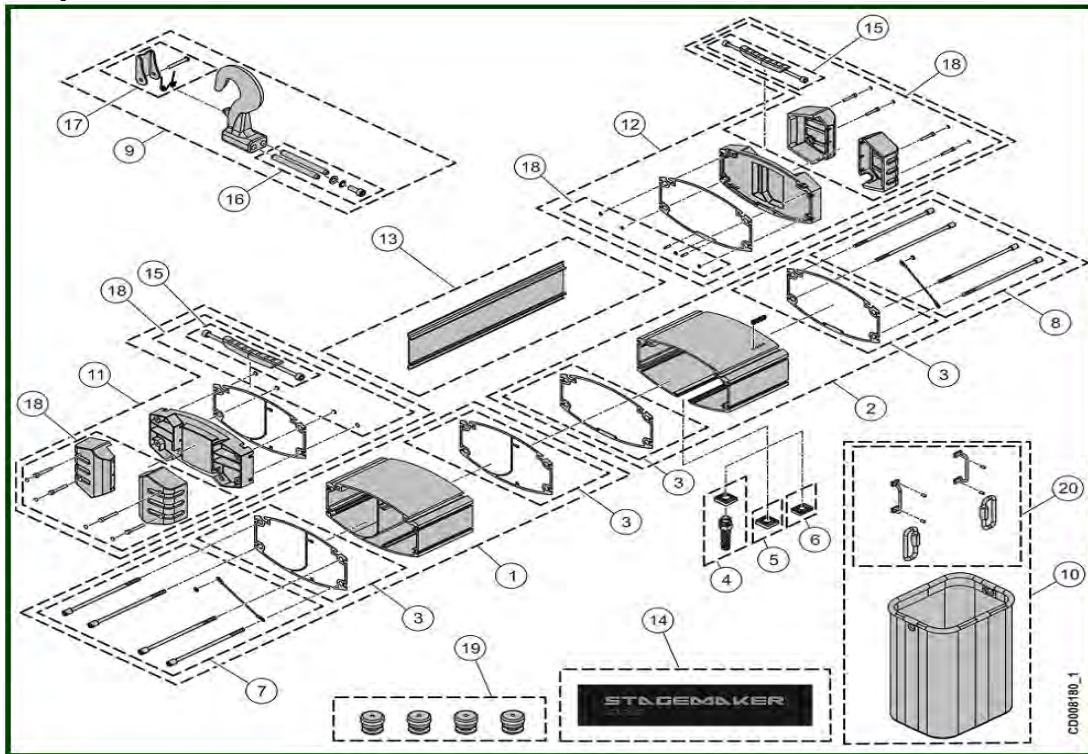

ITEM	REFERENCE	DESCRIPTION
1	VT0004555	Frame-Motor side Standard Single/double brake/GLS Double brake
2	VT0007013	Housing set - Brake side GLS - 2 steps - Single brake
2	VT0007014	Housing set - Brake side GLS - 4 steps - Double brakes
3	VT0004857	Seal set
4	VT0007033	Cable gland set with square cable entry PE ISO 25
5	VT0007034	End cap - Square cable entry PE ISO 25
6	VT0007035	Endcap/rectangular cable entry PE ISO/25 Double brake FDC 4 step
7	VT0006328	Screw set M6L161-Motor StF + GLS Single brake & Double brakes
8	VT0006327	Screw set M6L147 - Brake Standard + GLS 2 steps Single brake
8	VT0007016	Screw set M6L180 - Brake side GLS - Double brakes
9	VT0004967	Suspension hook set
10	VT0007018	Chain bucket 20 m - Reverse
10	VT0006002	Chain bucket 30m for 5x14 - 50m for 4x11 - Industrial/Normal
10	VT0007586	Chain bucket 40 m - Reverse
11	VT0006238	Cover set - Motor side
12	VT0006239	Cover set - Brake side (single/double brakes)
13	VT0006366	Housing Double brakes
13	VT0007019	Housing Single brake



14	VT0006038	Sticker – Brand Double brakes
14	VT0006007	Sticker – Brand Single brake
15	VT0006030	Set of 2 rubber handles (single/double brakes)
16	VT0004862	Shaft set
17	VT0005901	Hook assembly Standard
18	VT0006035	Handle + Protection set
19	VT0006090	Set of 4 plug set
20	VT0006036	Fixing set of chain bucket 20 m - Reverse
20	VT0004860	Fixing set of chain bucket
-	VT0006091	Set of 10 load plates – Hoist 250 Kg
-	VT0006243	Set of 10 load plates – Hoist 500 kg
-	VT0006241	Set of 10 stickers load – Hoist 125 Kg
=	VT0006026	Identification plate - Motor
=	VT0006944	Rain cover - Serial number required

## 2) CHAIN GUIDE 5X14 + HOOK BLOCK

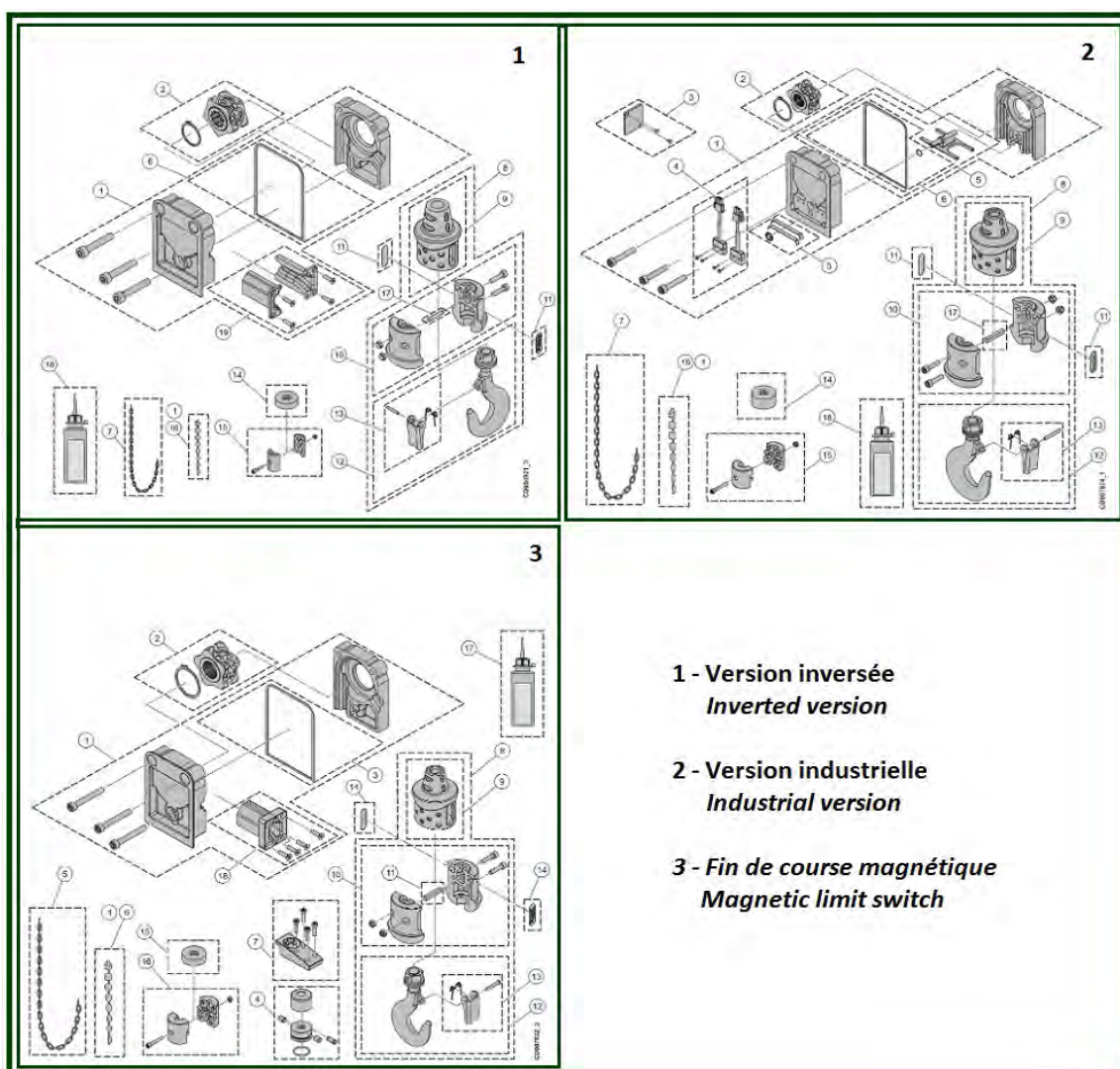

## 2.1) INVERTED VERSION

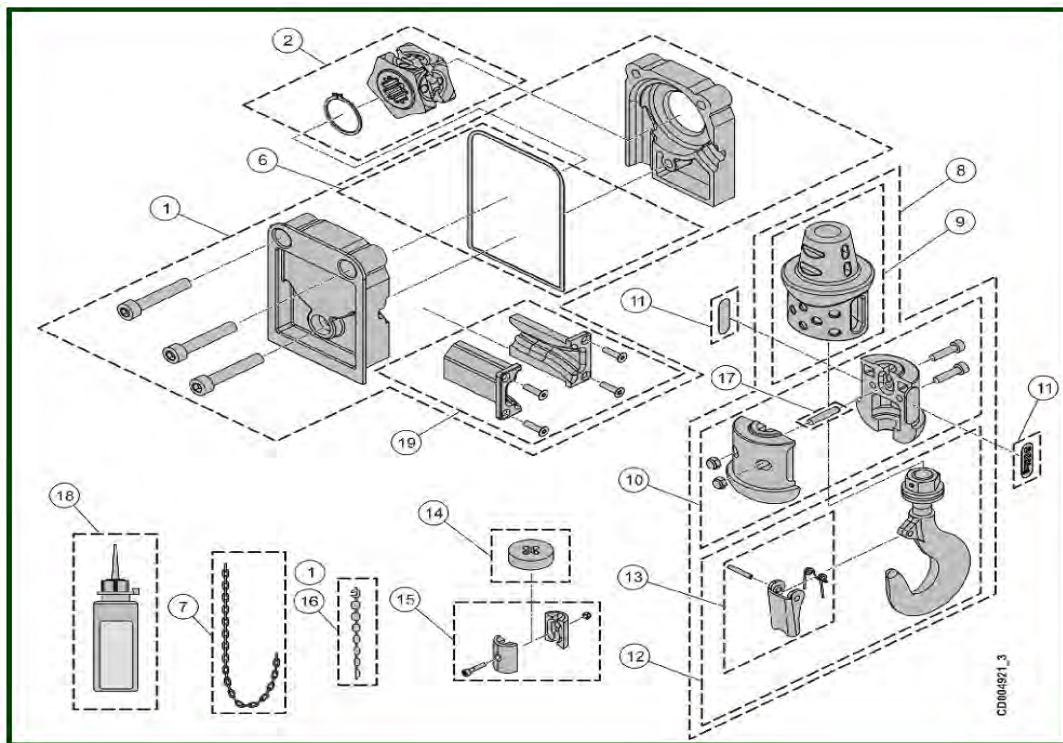

ITEM	REFERENCE	DESCRIPTION
1	VT0006064	Chain guide - Chain 5x14 Inverted version
2	VT0005106	Chain sprocket
6	VT0006272	Seal L102,5W76,5T0,5
7	VT0006023	Black chain 5x14
8	VT0007021	Complete hook block 1 fall
9	VT0004971	Rubber chain stop
10	VT0006063	Hook component
11	VT0006031	Set of 10 load plates – Hoist 250 kg - 4 m/min
11	VT0006041	Set of 10 stickers load – Hoist 500 Kg
12	VT0006042	Hook assembly
13	VT0004968	Safety latch set Single brake-Standard hook 0,12T-0,25T
14	VT0008153	Buffer D40T10
15	VT0004877	Chain stop L34W34H50
16	VT0005574	Chain fitting tool
17	VT0006240	Shaft
18	VT0007025	Oil can
19	VT0008549	External chain guide

## 2.2) INDUSTRIAL VERSION

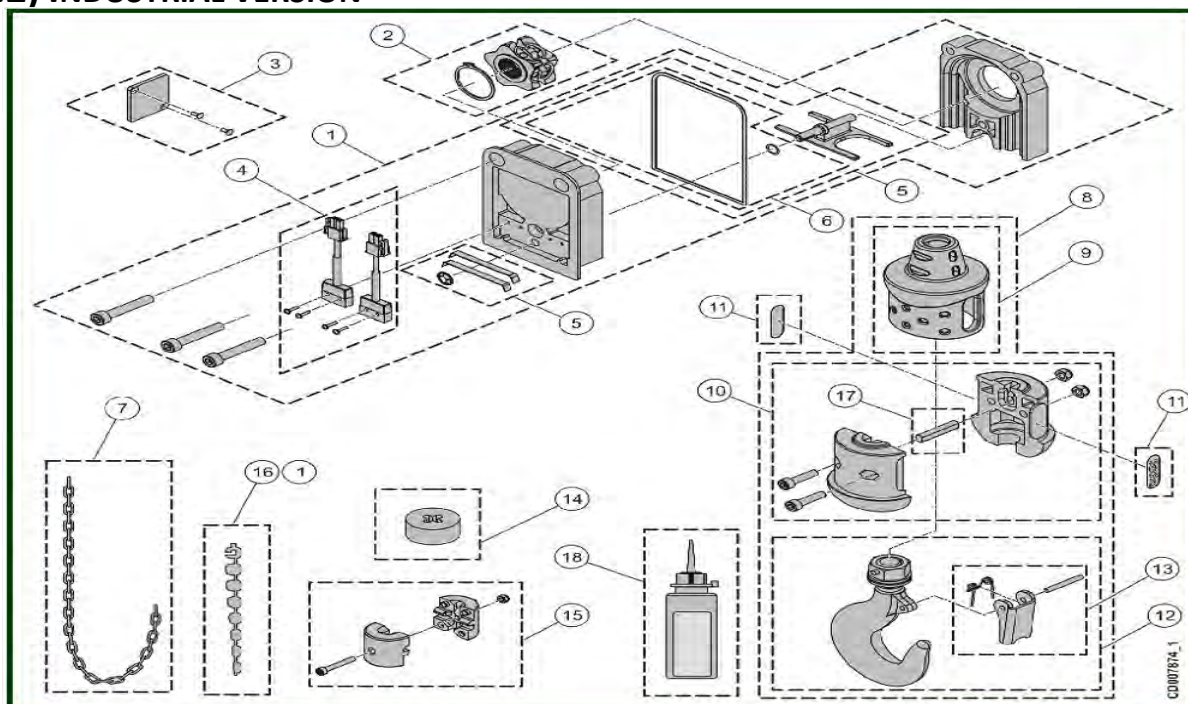

ITEM	REFERENCE	DESCRIPTION
1	VT0004875	Chain guide - Chain 5x14 v
2	VT0005106	Chain sprocket
3	VT0004870	Cap Chain guide
4	VT0004724	Switch set
5	VT0004872	Limit switch activator
6	VT0004871	Seal set
7	VT0006023	Black chain 5x14
8	VT0007021	Complete hook block 1 fall
9	VT0004971	Rubber chain stop
10	VT0006063	Hook component
11	VT0006031	Set of 10 load plates – Hoist 250 kg - 4 m/min
11	VT0006041	Set of 10 stickers load – Hoist 500 Kg
12	VT0006042	Hook assembly
13	VT0004968	Safety latch set Single brake-Standard hook 0,12T-0,25T
14	VT0008153	Buffer D40T10
15	VT0004877	Chain stop L34W34H50
16	VT0005574	Chain fitting tool
17	VT0006240	Shaft
18	VT0007025	Oil can

## 2.3) MAGNETIC LIMIT SWITCH

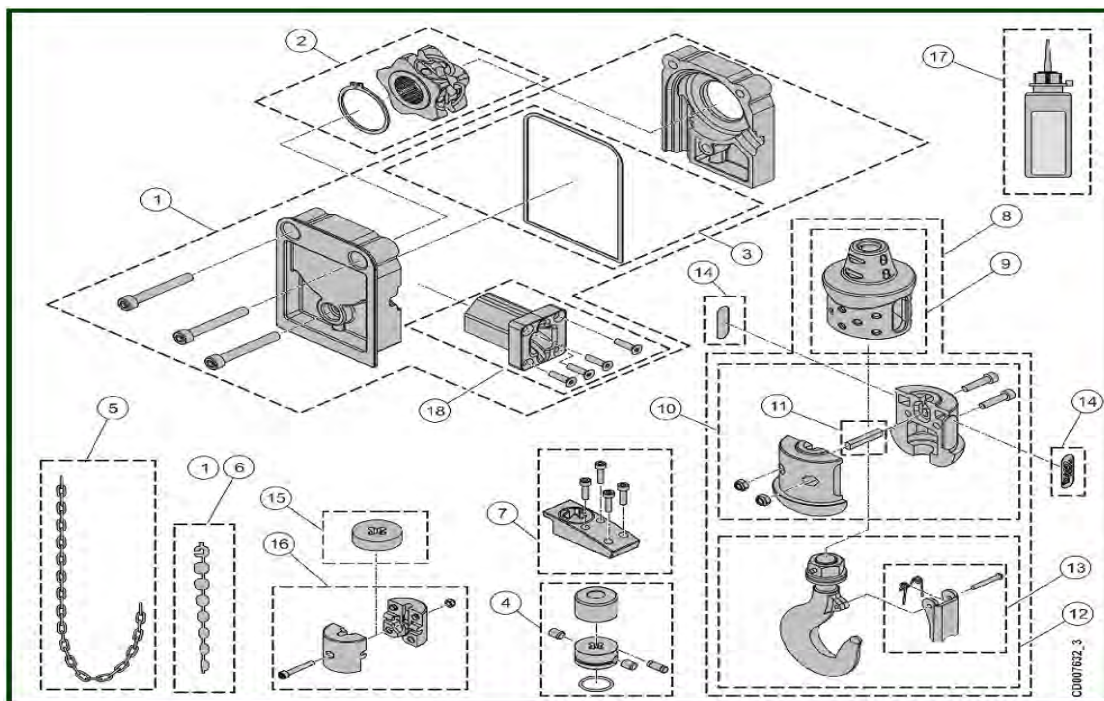

ITEM	REFERENCE	DESCRIPTION
1	VT0006064	Chain guide - Chain 5x14 Inverted version
2	VT0005106	Chain sprocket
3	VT0006272	Seal L102,5W76,5T0,5
4	VT0007407	Limit switch activator
5	VT0006023	Black chain 5x14
6	VT0005574	Chain fitting tool
7	VT0007408	Set of chain entry
8	VT0007021	Complete hook block 1 fall
9	VT0004971	Rubber chain stop
10	VT0006063	Hook component
11	VT0006240	Shaft
12	VT0006042	Hook assembly
13	VT0004968	Safety latch set Single brake-Std hook 0,12T-0,25T
14	VT0007577	Set of 10 stickers load – Hoist 250 Kg
14	VT0007579	Set of 10 stickers load – Hoist 500 Kg
15	VT0008153	Buffer D40T10
16	VT0004877	Chain stop L34W34H50
17	VT0006025	Oil can
18	VT0008549	External chain guide



### 3) GEAR

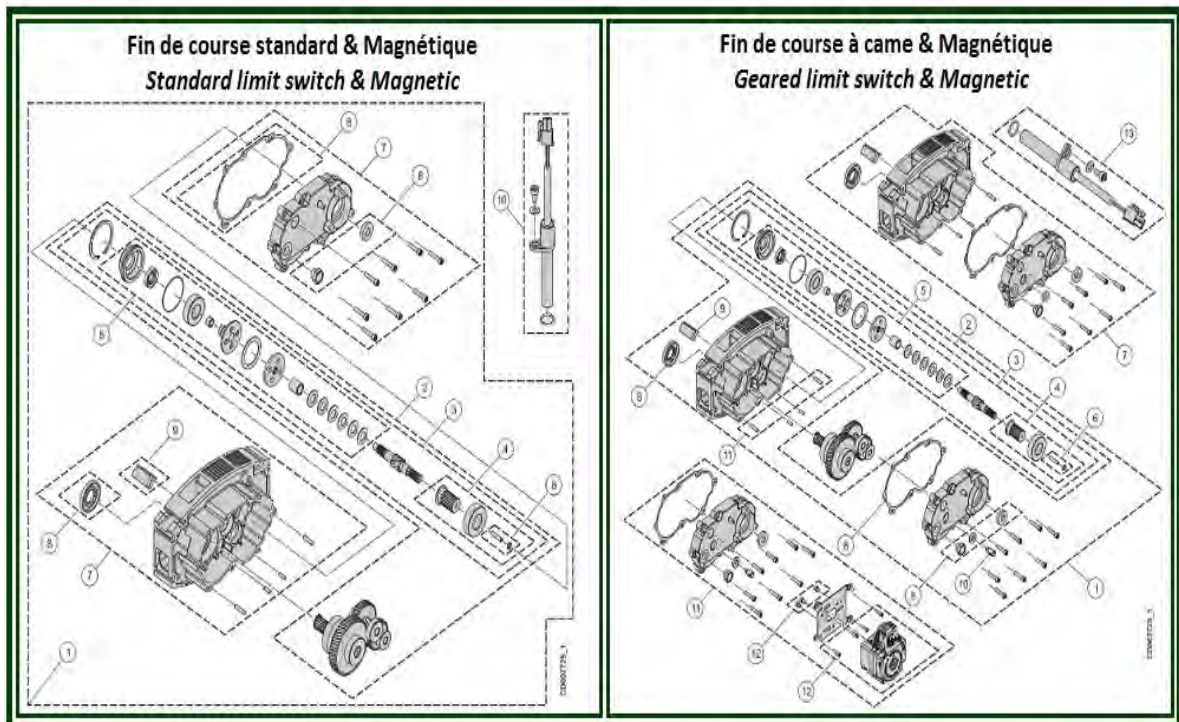

#### 3.1) 8 & 16 m/MIN - STANDARD LIMIT SWITCH & MAGNETIC

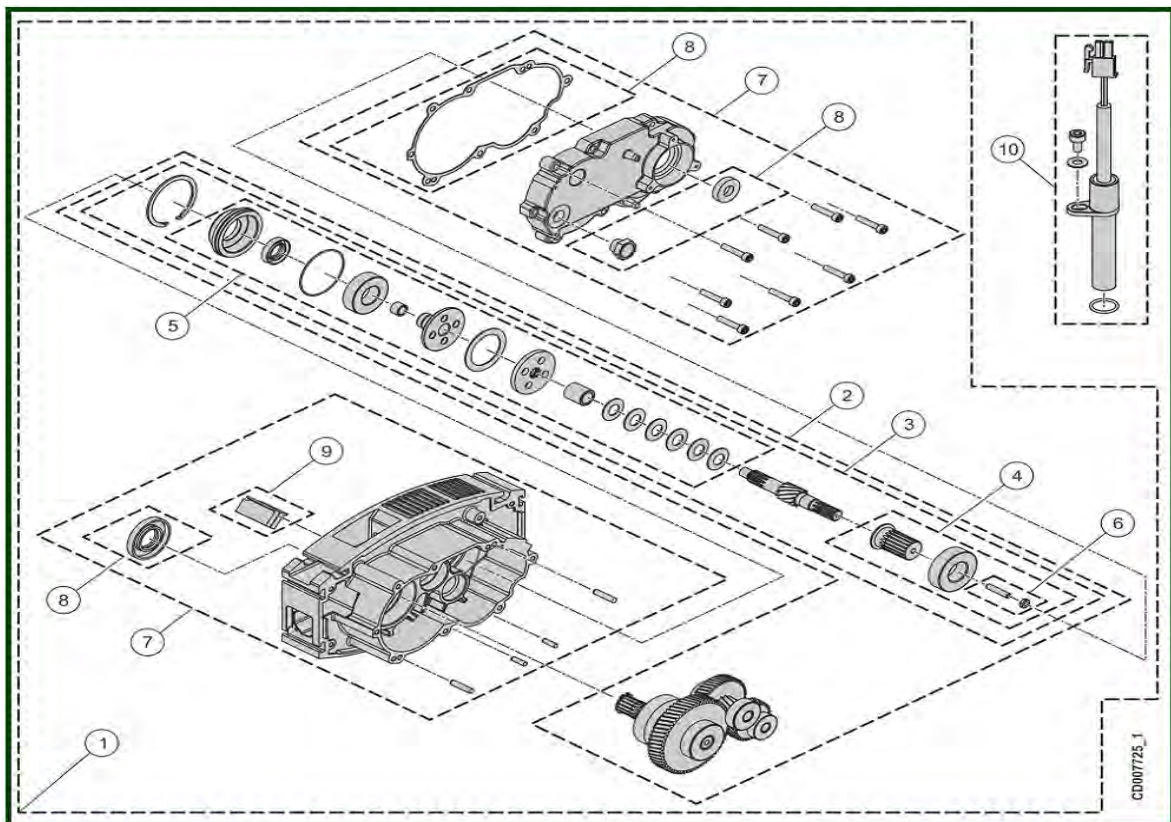

ITEM	REFERENCE	DESCRIPTION
1	VT0007003	Gear assembly - 8 m/min GLS & Standard - Single brake
1	VT0007001	Gear assembly - 8 m/min Standard - Double brake

1	VT0007002	Gear assembly - 16 m/min Standard - Double brake
1	VT0007000	Gear assembly - 16 m/min Standard - Single brake
2	VT0006468	Gear / Pinion set - 8 m/min Standard - Single brake
2	VT0006470	Gear / Pinion set - 16 m/min Standard - Single brake
3	VT0006503	Gear shaft with clutch - 8 m/min Double brakes
3	VT0004885	Gear shaft with clutch - 8 m/min Single brake
3	VT0006248	Gear shaft with clutch - 16 m/min Double brake
3	VT0007011	Gear shaft with clutch - 16 m/min Single brake
4	VT0006247	Coupling - Brake side Double brakes
4	VT0006246	Coupling - Brake side Single brake
5	VT0004887	Clutch
6	VT0006107	Screw set
7	VT0006997	Frame Standard
8	VT0004890	Seal set Standard
9	VT0004976	Grommet
10	VT0007547	Hoisting limit switch Magnetic

### 3.2) 8 & 16 M/MIN - GEARED LIMIT SWITCH & MAGNETIC

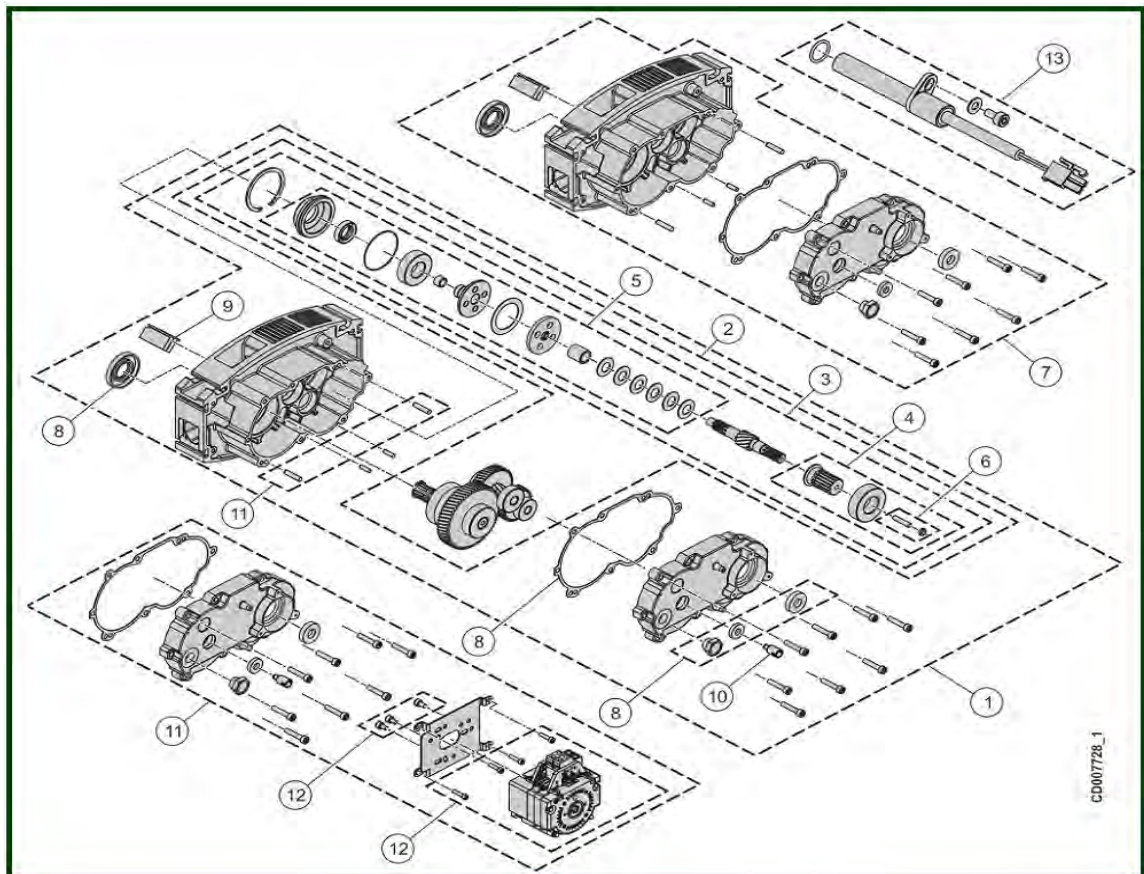

CD000728\_1

ITEM	REFERENCE	DESCRIPTION
1	VT0007003	Gear assembly - 8 m/min GLS & Standard - Single brake
1	VT0007005	Gear assembly - 8 m/min GLS - Double brakes
1	VT0007006	Gear assembly - 16 m/min GLS - Double brakes
1	VT0007004	Gear assembly - 16 m/min GLS - Single brake
2	VT0007009	Gear / Pinions set - 8 m/min GLS - Double brake
2	VT0007007	Gear / Pinions set - 8 m/min GLS - Single brake
2	VT0007010	Gear / Pinions set - 16 m/min GLS - Double brake
2	VT0007008	Gear / Pinions set - 16 m/min GLS - Single brake
3	VT0006503	Gear shaft with clutch - 8 m/min Double brakes
3	VT0004885	Gear shaft with clutch - 8 m/min Single brake
3	VT0006248	Gear shaft with clutch - 16 m/min Double brake
3	VT0007011	Gear shaft with clutch - 16 m/min Single brake
4	VT0006247	Coupling - Brake side Double brakes
4	VT0006246	Coupling - Brake side Single brake
5	VT0004887	Clutch
6	VT0006107	Screw set
7	VT0006998	Frame GLS
8	VT0006250	Seal set Rotating limit switch
9	VT0004976	Grommet
10	VT0006251	Gearwheel Geared limit switch
11	VT0006256	Geared limit switch-2 steps/Adaptor set Lift height 20M
11	VT0006255	Geared limit switch-4 steps/Adaptor set Lift height 20M
12	VT0006113	Geared limit switch/screw set 2 step VR02F=20m 1 fall-10m: 2 fall VR05F=25m: 1 fall-12.5m 2 fall VR10F=36m 1 fall-18m: 2 fall VR16F=48m: 1 fall-24m: 2 fall VR25F=56m 1 fall-28m: 2 fall
12	VT0006252	Geared limit switch with screw set 4 step VR02F=20m 1 fall-10m 2 fall VR05F=25m: 1 fall-12.5m 2 fall VR10F=36m 1 fall-18m 2 fall VR16F=48m: 1 fall-24m: 2 fall VR25F=56m 1 fall-28m 2 fall
13	VT0007547	Hoist limit switch Magnetic



## 4) MOTOR

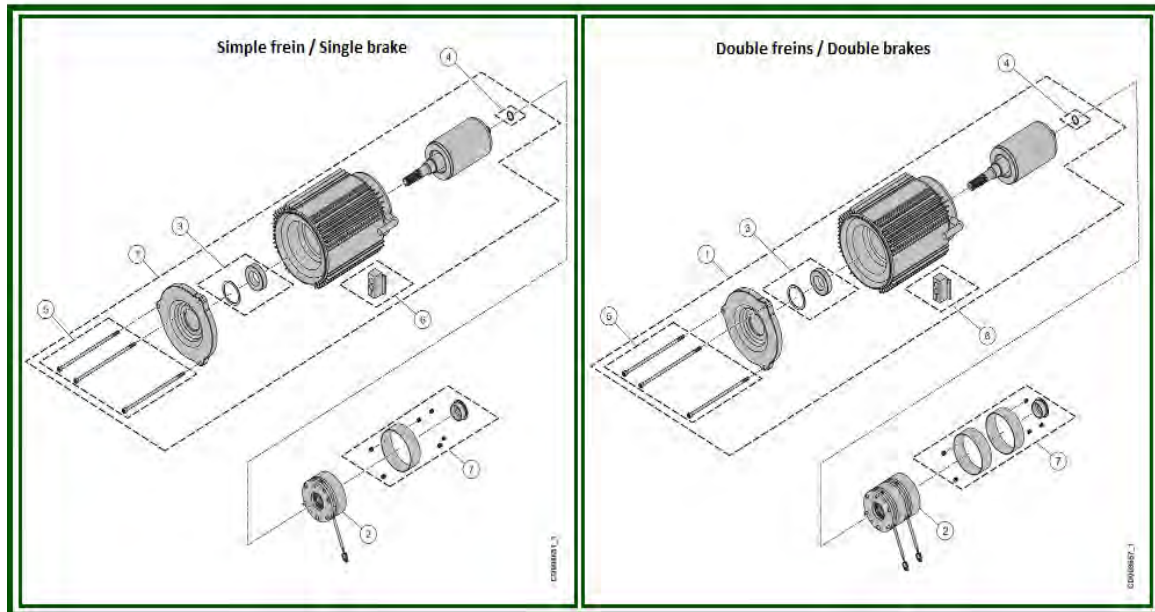

### 4.1) SINGLE BRAKE

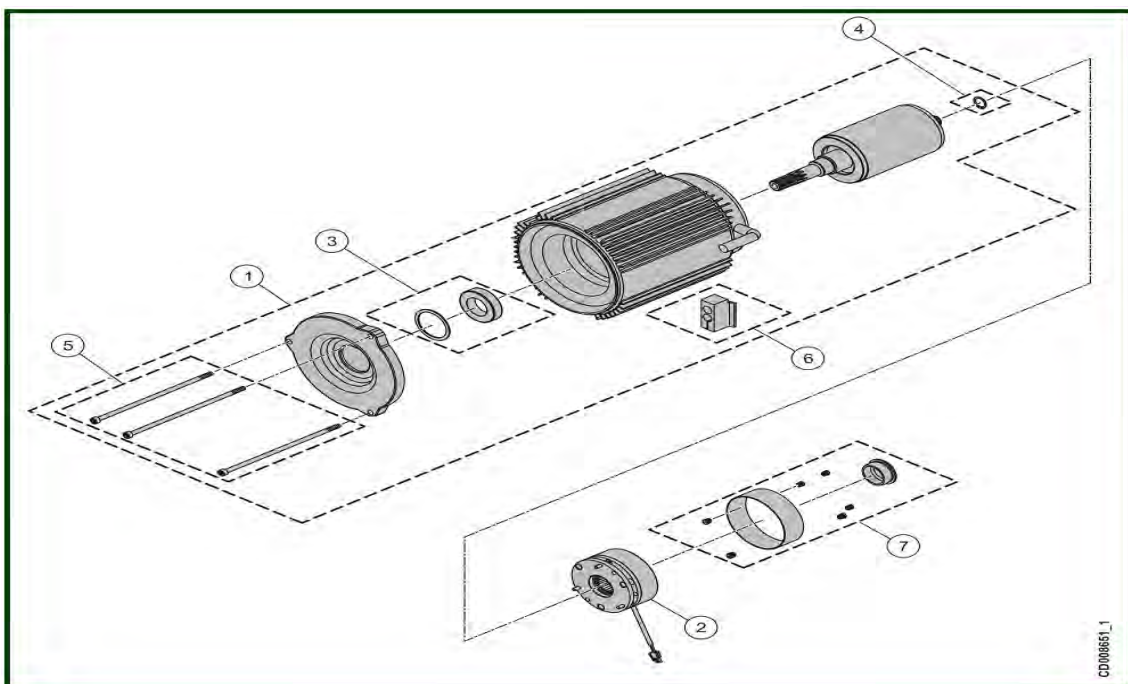

ITEM	REFERENCE	DESCRIPTION
1	VT0007052	Motor - 1 speed 208V-230V 60Hz 1500 - 4 m/min
1	VT0006266	Motor-1 speed 380V-415V 50Hz /440V-480V 60Hz 1500-4 m/min
1	VT0007054	Motor - 2 speed 208V-230V 60Hz 8m/min - 16m/min
1	VT0007053	Motor-2 sp 380V-415V 50Hz/440V-480V 60Hz 8m/min-16m/min
2	VT0008041	Single brake - 103V Since October 2015-week 41
2	VT0008042	Single brake - 190V Since October 2015-week 41



3	VT0006267	Bearing set
4	VT0004977	Retaining ring
5	VT0006485	Screws set M6x160
6	VT0004976	Grommet
7	VT0009220	Waterproof sealings set for the brake Single brake

## 4.2) DOUBLE BRAKE

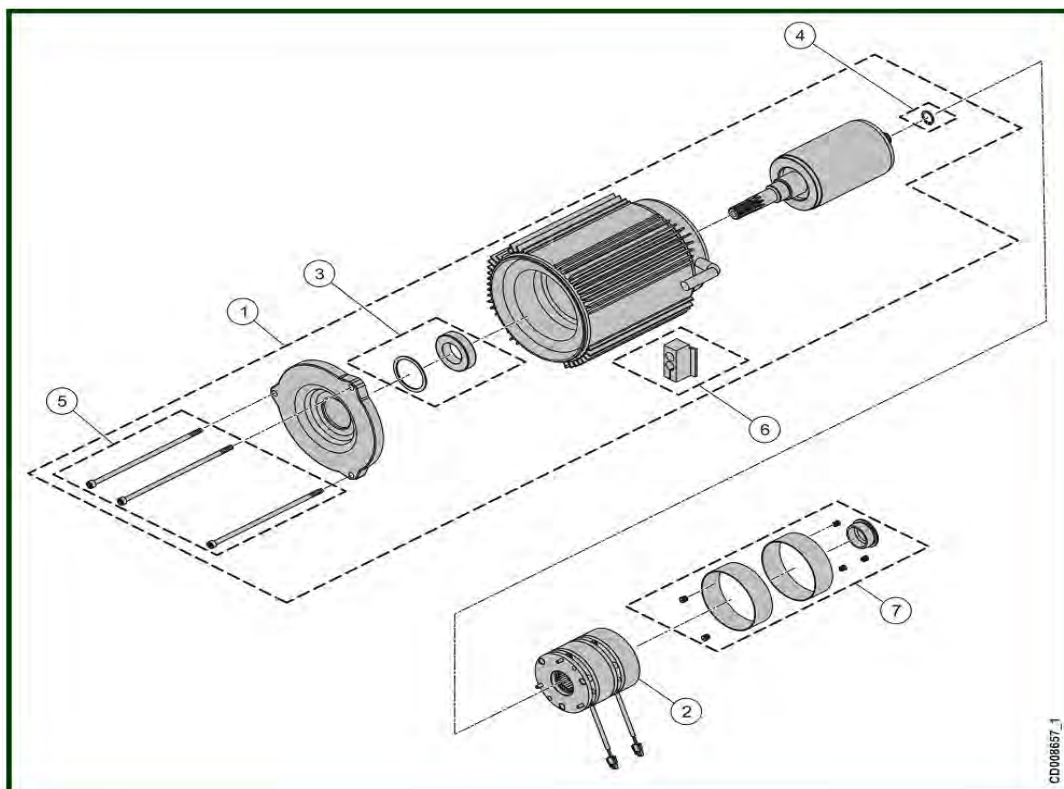

ITEM	REFERENCE	DESCRIPTION
1	VT0007052	Motor - 1 speed 208V-230V 60Hz 1500 - 4 m/min
1	VT0006266	Motor -1 SP 380V-415V 50 Hz/440V-480V 60Hz 1500-4m/min
1	VT0007054	Motor - 2 speed 208V-230V 60Hz 8m/min - 16m/min
1	VT0007053	Motor-2 SP 380V-415V 50Hz/440V-480V 60Hz 8m/min-16m/min
2	VT0008043	Double brakes - 103V Since October 2015-week 41
2	VT0008044	Double brakes - 190V Since October 2015-week 41
3	VT0006267	Bearing set
4	VT0004977	Retaining ring
5	VT0006485	Screw set M6x160
6	VT0004976	Grommet
7	VT0009221	Waterproof sealings set for the brake Double brakes

## 5) ELECTRICAL PARTS

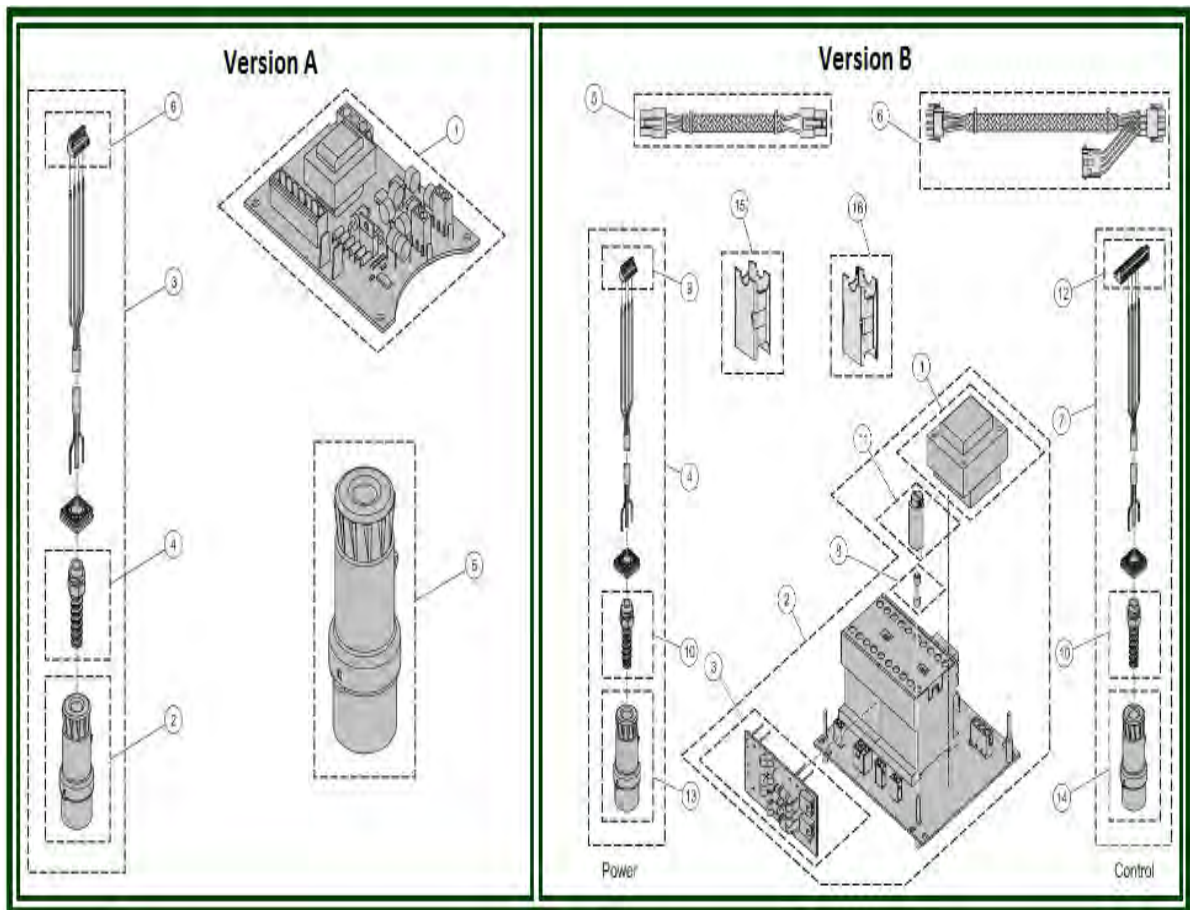

### 5.1) VERSION A

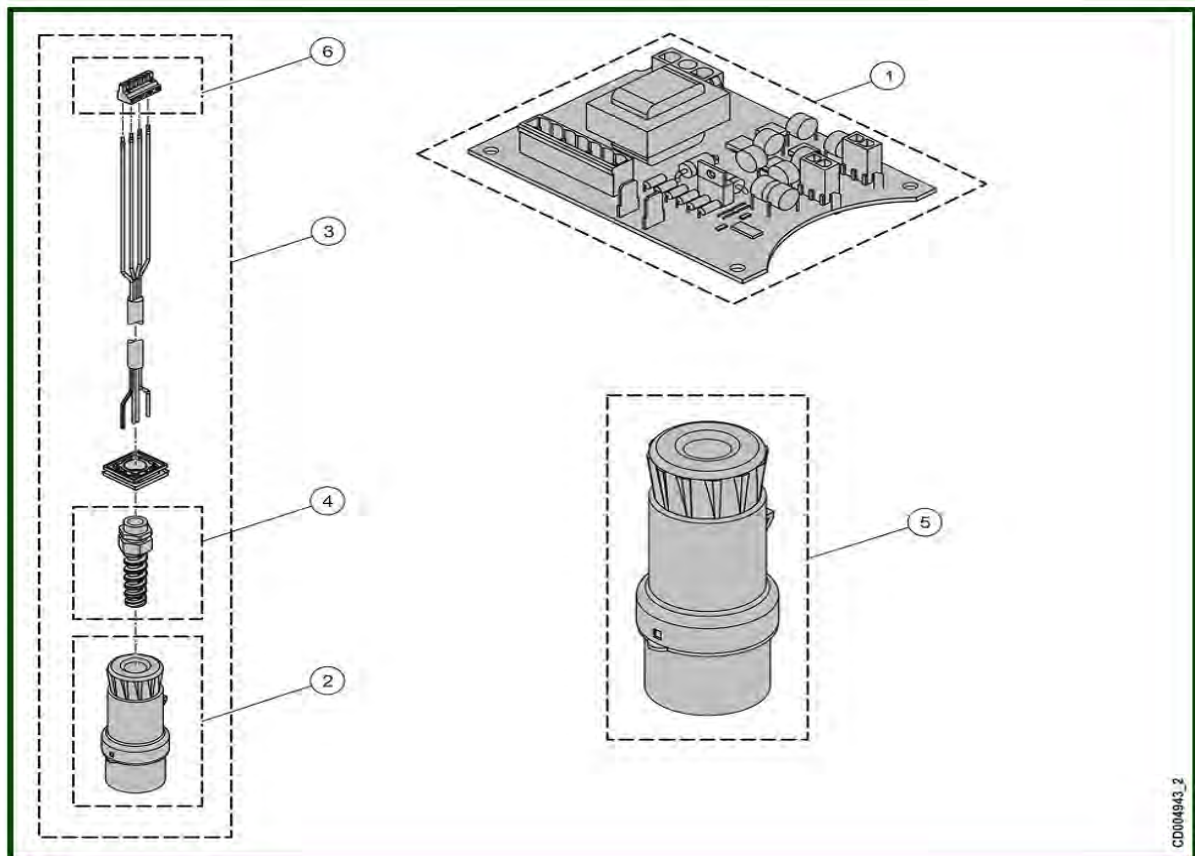

ITEM	REFERENCE	DESCRIPTION
1	VT0006000	ACF card 208-600V single speed
2	VT0006087	Power supply male blue plug 230V / 3P+T
2	VT0006086	Power supply male red plug 400V / 3P+T
3	VT0006078	Power supply male blue plug/cable 230V/50-60Hz / 3P+T 0,5m
3	VT0006076	Power male red plug/cable 380-415V/50-60Hz-400-3P+T 0,5m
4	VT0006399	Spiral cable gland
5	VT0006085	Female blue plug 230V / 3P+T
5	VT0006001	Female red plug 400V / 3P+T
6	VT0005107	Power connector 4P

## 5.2) VERSION B

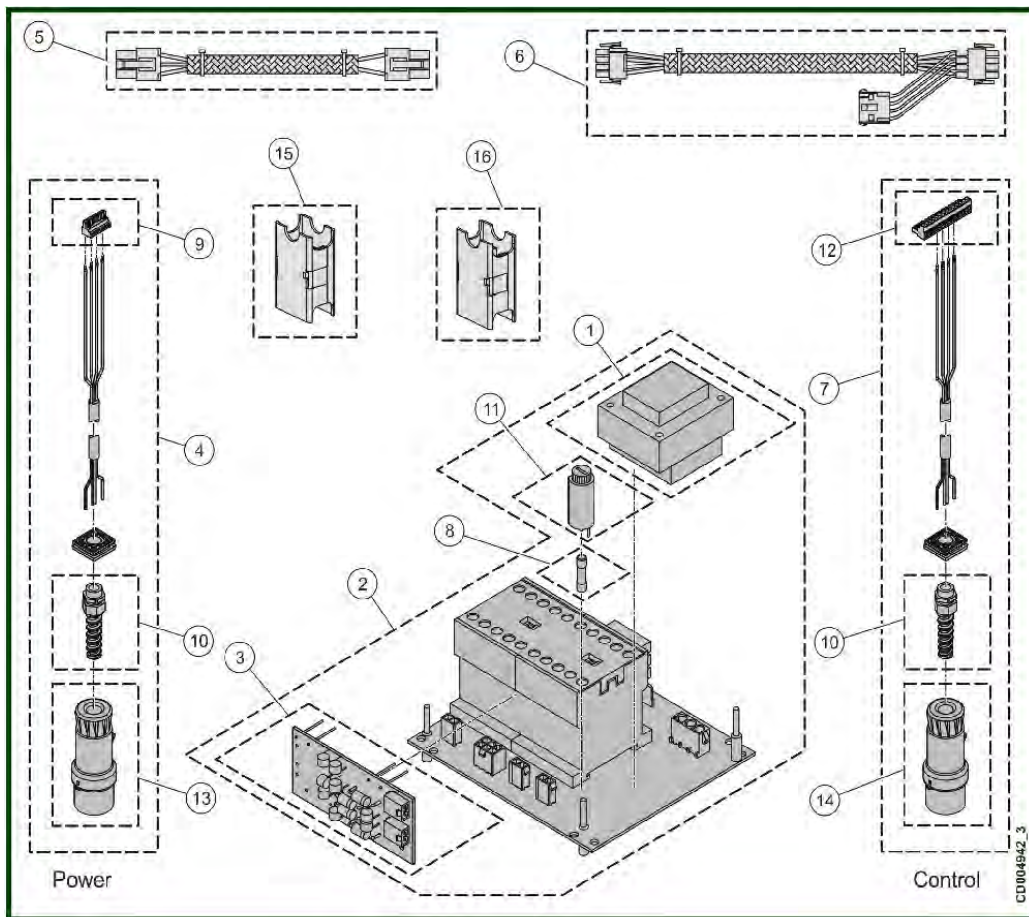

ITEM	REFERENCE	DESCRIPTION
1	VT0006193	Transformer 208V / 115V
1	VT0006407	Transformer 230V / 48V
1	VT0006408	Transformer 230V / 115V
1	VT0006192	Transformer 400V / 48V

1	VT0006406	Transformer 460V / 115V
2	VT0006097	Electrical board - 1 speed - 2 brakes 208V / 50-60HZ / 115V
2	VT0006404	Electrical board - 1 speed - 2 brakes 230V / 50HZ / 48V
2	VT0006405	Electrical board - 1 speed - 2 brakes 230V / 50HZ / 115V
2	VT0006099	Electrical board - 1 speed - 2 brakes 400V / 50HZ / 48V
2	VT0006098	Electrical board - 1 speed - 2 brakes 460V / 50-60HZ / 115V
3	VT0004947	Rectifier - 2 brakes 230V-690V
4	VT0006078	Power male blue plug/cable 230V/50-60Hz / 3P+T 0,5m
4	VT0006076	Power male red plug/cable 380-415V/50-60Hz-400-3P+T 0,5m
5	VT0004949	Wire harness - Plug control voltage
6	VT0004950	Wire harness - Plug power voltage
7	VT0006409	Control yellow plug with cable
8	VT0006194	Fuse set 48V
8	VT0006195	Fuse set 115V
9	VT0005107	Power connector 4P
10	VT0006399	Spiral cable gland
11	VT0006191	Fuse base
12	VT0006412	Control connector - 5 P
13	VT0006087	Power supply male blue plug 230V / 3P+T
13	VT0006086	Power supply male red plug 400V / 3P+T
14	VT0006761	Control yellow plug – Female 115V - 3P+T
15	VT0006410	Power adapter 208V-600V
16	VT0006411	Control adapter 24V-230V