

Spare parts catalogue for "VL02-VL05-XC1 – After June 2003"

To avoid errors, when ordering please specify:

- Complete type of hoist
- Date of manufacture and serial number
- Spare part code
- Spare part designation
- Additional information



1. HOISTING MOTOR AND CASING	2
1.1. Specific item for single phased Hoist.....	4
2. MECHANISM / BRAKE - THREE PHASES	5
2.1. Specific item for single phased Hoist.....	6
3. LIFTING ASSEMBLY.....	7
3.1. Precut chain.....	10
4. ELECTRIC STANDARD BOX	11
4.1. Specific item for single phased Hoist.....	13
5. Standard upper and lower limit switch	15
6. Cam operated limit switch - Option	16
7. CHV TROLLEY – SINCE 2003	17
7.1. Inverter motor TMU	20
7.2. Two speeds TMU motor	22
7.3. Chain travel.....	24
7.4. Right angle motor	25
8. LOW HEADROOM TROLLEY – SINCE JUIN 2003	26
8.1. LHT trolley.....	27
8.2. Coupling cross member & lower suspension	28
8.3. Flanges adjustments.....	30
8.4. Travelling machinery 1 & 2 – Variation speed.....	31
8.5. Travelling machinery – Two speeds	32

1. HOISTING MOTOR AND CASING

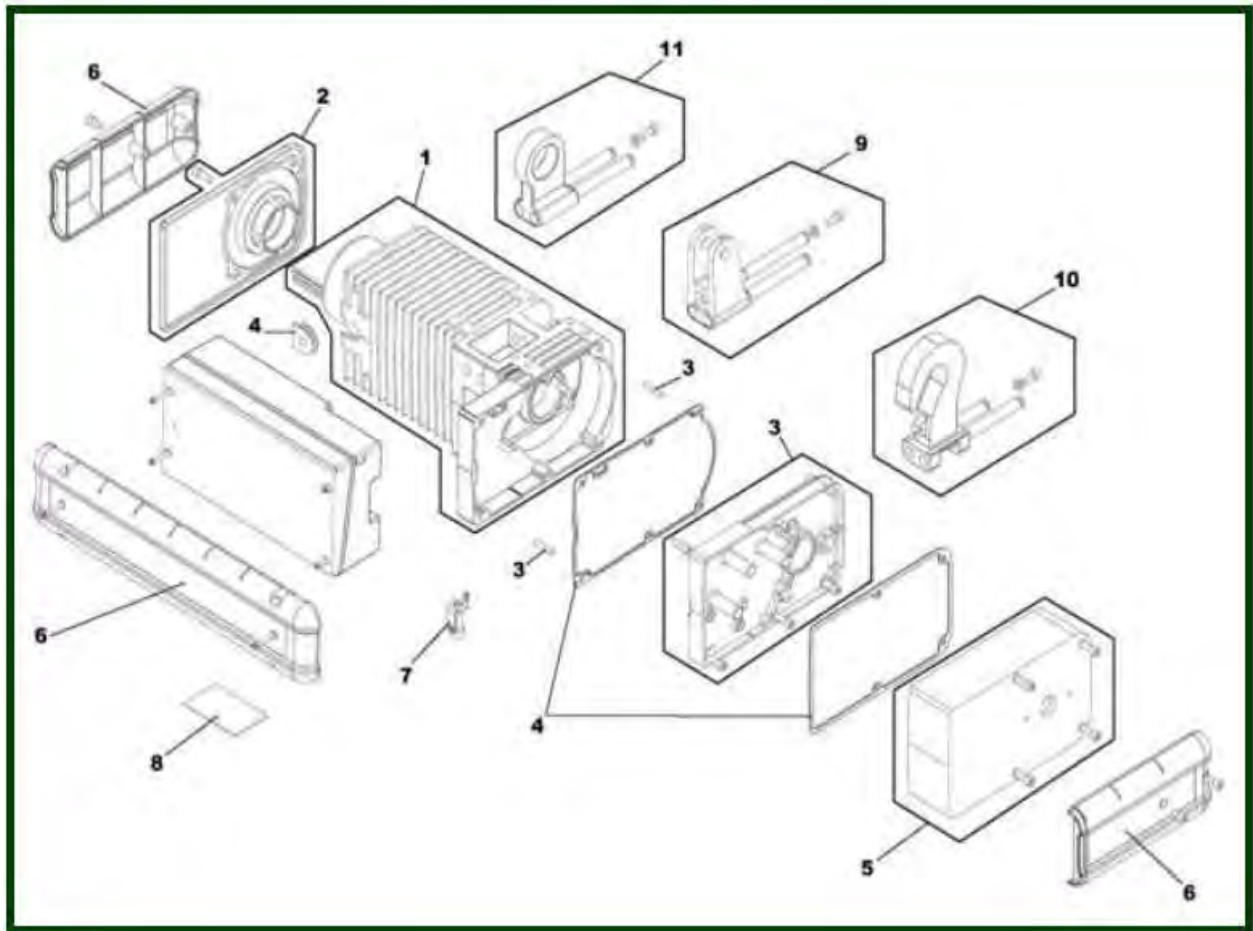

Item	Reference	Description	Observation	Quantity
1	<u>52308704</u>	Casing assembled with stator	230V 50Hz BIM.2&8P	1
1	<u>52308697</u>	Casing assembled with stator	230V 50Hz 3PH.2&8P	1
1	<u>52308705</u>	Casing assembled with stator	230V 60Hz BIM.2&8P	1
1	<u>52308699</u>	Casing assembled with stator	230V 60Hz 3PH.2&8P	1
1	<u>52308709</u>	Casing assembled with stator	230V 460V 60Hz BIM.2P	1
1	<u>52308710</u>	Casing assembled with stator	230V 400V 60Hz BIM.4P	1
1	<u>52308696</u>	Casing assembled with stator	400V 50Hz 3PH.2&8P	1
1	<u>52308707</u>	Casing assembled with stator	400V 50Hz BIM.4P	1
1	<u>52308703</u>	Casing assembled with stator	400V 60Hz BIM.2&8P	1
1	<u>52308698</u>	Casing assembled with stator	400V 60Hz 3PH.2&8P	1
1	<u>52308708</u>	Casing assembled with stator	500V 50Hz BIM.4P	1
1	<u>52308700</u>	Casing assembled with stator	500V 50Hz 3PH.2&8P	1
1	<u>52308706</u>	Casing assembled with stator	500V 50Hz 2V BIM	1
2	<u>52308741</u>	Motor flange assy		1
3	<u>52308742</u>	Gear cover set		1
4	<u>52308768</u>	Set of sealings		1
5	<u>52308747</u>	Brake cover set		1
6	<u>2216051</u>	Marking & covers set	VL5	1
6	<u>2216053</u>	Marking & covers set	XC1	1
6	<u>52328161</u>	Marking & covers set	XC1 RNUR	1
7	<u>2218000</u>	Push button station fixing point		1
8	<u>2219938</u>	Set of 10 load plates - Hoist	125 kg	1
8	<u>2219917</u>	Set of 10 load plates - Hoist	160 kg	1
8	<u>2219918</u>	Set of 10 load plates - Hoist	250 kg	1
8	<u>2219919</u>	Set of 10 load plates - Hoist	320 kg	1
8	<u>2219920</u>	Set of 10 load plates - Hoist	500 kg	1
8	<u>2219921</u>	Set of 10 load plates - Hoist	630 kg	1
8	<u>2219922</u>	Set of 10 load plates - Hoist	1 000 kg	1
9	<u>2229920</u>	Crosshead set + Shaft and screws	Parallel suspension : CHM Perpendicular mounting : CHR	1
9	<u>2229921</u>	Crosshead set + Shaft and screws	Parallel suspension : CHR Perpendicular suspension: CHM	1
10	<u>2219954</u>	Ensemble crochet	Parallel suspension	1
10	<u>2219955</u>	Ensemble crochet	Perpendicular suspension	1
11	<u>52308832</u>	Suspension eye CHD		1
-	<u>2212017</u>	Safety latch - Steel plate type - 025T	1 & 2 falls - Since 2000	1
-	<u>52308744</u>	Cap - Brake side		1
-	<u>52308852</u>	Rain cover		1
-	<u>VT0006026</u>	Identification plate	Serial number request	1

1.1. Specific item for single phased Hoist

Item	Reference	Description	Observation	Quantity
1	<u>52316246</u>	Casing assembled with stator	115V 50Hz - Single phase	1
1	<u>52316249</u>	Casing assembled with stator	115V 60Hz - Single phase	1
1	<u>52316245</u>	Casing assembled with stator	230V 50Hz - Single phase	1
1	<u>52316247</u>	Casing assembled with stator	230V 60Hz - Single phase	1
1	<u>52316247</u>	Casing assembled with stator	230V 60Hz BIM - Single phase	1

2. MECHANISM / BRAKE - THREE PHASES

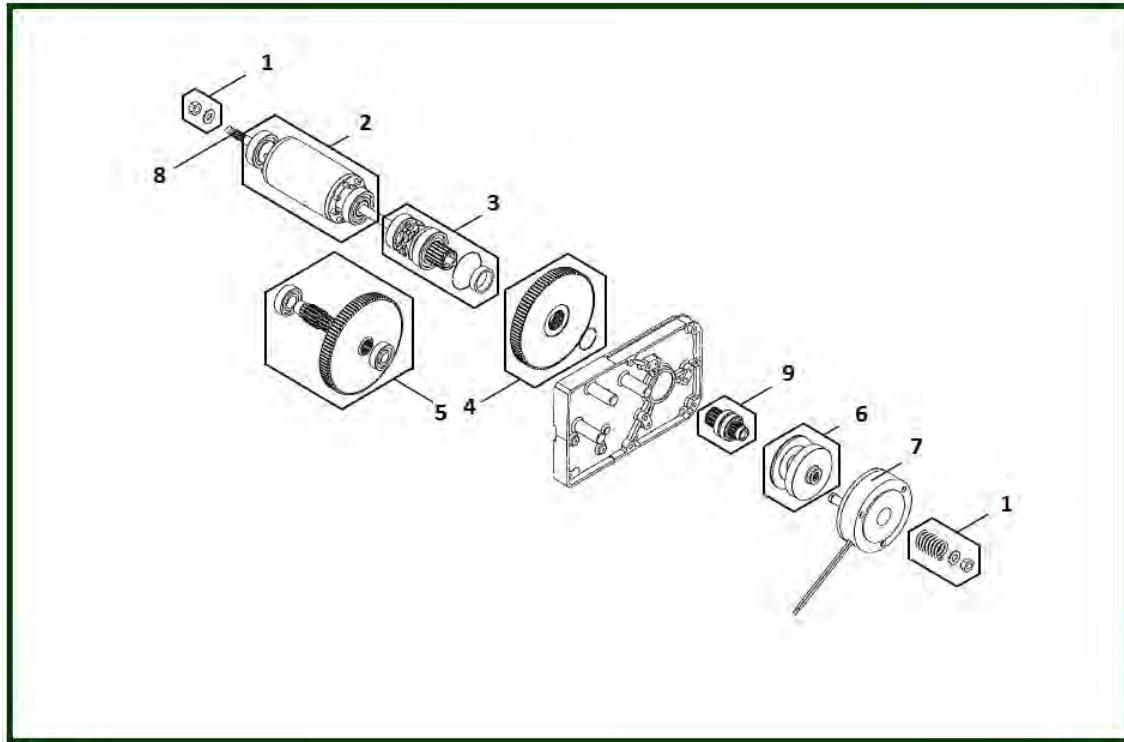

Item	Reference	Description	Observation	Quantity
1	2211016	Clutch spring set with motor shaft		1
2	52305652	Ensemble rotor		1
3	52305659	Chain sprocket assembly		1
4	52305473	Gear wheel set	8 m/mn	1
4	52308850	Gear wheel set	16 m/mn	1
5	52308771	Gear assembly	8 m/mn	1
5	52315180	Gear assembly	16 m/mn	1
6	52355493	Clutch set	To 125 kg - 1 fall	1
6	52308772	Clutch set	Higher than 125 kg - 1 fall	1
7	52305489	Brake	190VDC/400VAC	1
7	52305488	Brake	100VDC/230VAC	1
7	52305490	Brake	230VDC/500V-575VAC	1
7	52313462	Brake	330VDC/690VAC	1
8	52305461	Motor shaft		1
9	52305658	Pinion set		1

2.1. Specific item for single phased Hoist

Item	Reference	Description	Observation	Quantity
2	<u>52315793</u>	Rotor assembly - Single phase		1
6	<u>52315403</u>	Clutch set		1
-	<u>52319772</u>	Bush kit	Brake side - C6	1

3. LIFTING ASSEMBLY

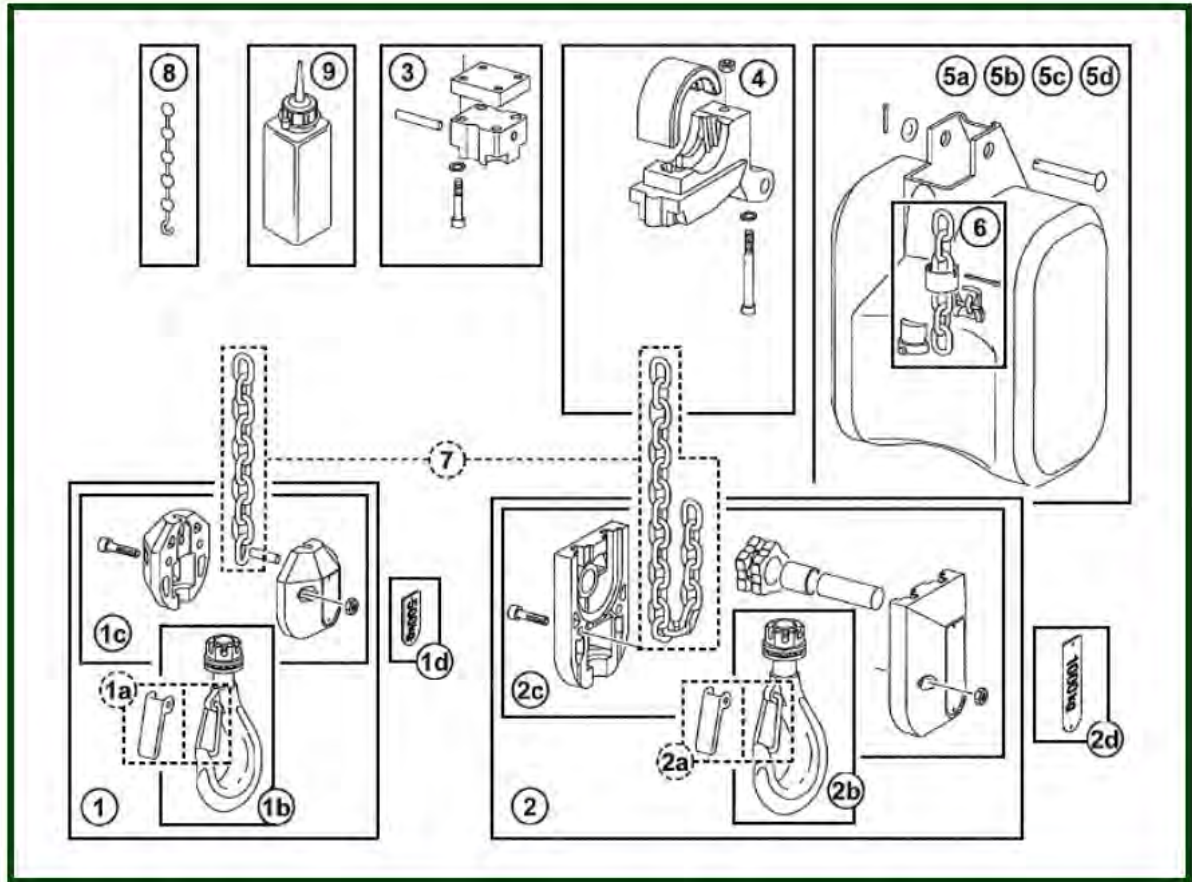

Item	Reference	Description	Observation	Quantity
1	2219902	Lower standard hook block assembly	1 fall - C5 - Short-Long	1
1	52371855	Lower hook block assembly Stainless steel type	1 fall	1
1	2212018	Lower hook block assembly Self-locking type	1 fall - 500 kg	1
1a	A001512	Safety latch - Steel wire type	1 fall - 2 falls - PHR - 500 kg	1
1a	2212016	Safety latch - Steel	Upper hook - 1 fall	1
1b	2217015	Lifting hook Self-locking type	1 fall - 2 falls	1
1b	2212011	Lifting steel standard hook	1 fall - 0.5 T	1
1b	52370687	Lifting hook - Stainless steel type	1 fall	1
1c	2219985	Set of 2 half-casings with axle and screws	1 fall	1
1d	2219937	Set of 10 load plates - 1 fall	125 kg	1
1d	2219906	Set of 10 load plates - 1 fall	160 kg	1
1d	2219908	Set of 10 load plates - 1 fall	320 kg	1
1d	2219907	Set of 10 load plates - 1 fall	250 kg	1
1d	2219909	Set of 10 load plates - 1 fall	500 kg	1
2	52371856	Hook block - Stainless steel	2 falls - 500kg-1Bm/2m	1
2	52371857	Hook block - Stainless steel	2 falls - 630 kg -1Bm	1
2	2212020	Hook block - Standard type	2 falls	1
2	2212028	Hook block - Self-locking type	2 falls - 1000 kg	1
2a	A001515	Safety latch - Steel wire type 025 or 012	1 fall - 2 falls - PHR : 1000 kg	1
2a	2212017	Safety latch - Steel plate type - 025T	1 fall - 2 falls - Since 2000	1
2b	2247015	Lifting hook Self-locking type	C06 : 2 falls - C10 : 1 fall	1
2b	52370688	Lifting hook - Inox	500kg-1Bm/2m C06 : 2 falls - C10 : 1 fall	1
2b	52370689	Lifting hook - Inox	630kg-1Bm - C06 : 2 falls- C10 : 1 fall	1
2b	2217004	Lifting hook standard - 025T	C05 : 2 falls - C10 : 1 fall	1
2c	2219987	Set of 2 half-casings, axle, return sprocket, and screws		1
2d	2219910	Set of 10 load plates - 2 falls	320 kg	1
2d	2219911	Set of 10 load plates - 2 falls	500 kg	1
2d	2219912	Set of 10 load plates - 2 falls	630 kg	1
2d	2219913	Set of 10 load plates - 2 falls	1000 kg	1
3	52309350	Chain anchor assembly		1
4	52305660	Lower chain guide with micro Switch		1
4a	52305498	Rubber buffer		1

5a	<u>2219990</u>	Chain bucket	8 m	1
5b	<u>2249925</u>	Chain bucket	C05 : 16 m - C10 : 8 m	1
5c	<u>2249926</u>	Chain bucket	C05 : 30 m - C10 : 16 m	1
5d	<u>2249932</u>	Chain bucket	C05 : 50 m - C10 : 30 m	1
5e	<u>2211036</u>	Chain bucket for windmill	C05 : 80 m - C10 : 50 m	1
6	<u>2211050</u>	Slack fall stop assembly		1
7	<u>2213500V</u>	Galvanized load chain - 4.8x12.5		1
7	<u>2213501V</u>	Black load chain - 4.8x12.5		1
7	<u>2213502V</u>	Stainless steel chain - 4.8x12.5	Be careful at load capacity	1
8	<u>2211045</u>	Load chain mounting tool		1
9	<u>9995008</u>	Oil can	125 ml	1
-	<u>52309351</u>	Upper and lower chain guide assembly with rubber buffer	Option – Without limit	1
-	<u>52265593</u>	Micro switch		1

3.1. Precut chain

Item	Reference	Description	Observation	Quantity
	<u>53019924</u>	Galvanized load chain - 4.8x12.5	3,2 meters	1
	<u>53019930</u>	Galvanized load chain - 4.8x12.5	4 meters	1
	<u>53019932</u>	Galvanized load chain - 4.8x12.5	5 meters	1
	<u>53019937</u>	Galvanized load chain - 4.8x12.5	6 meters	1
	<u>53019938</u>	Galvanized load chain - 4.8x12.5	7 meters	1
	<u>53019943</u>	Galvanized load chain - 4.8x12.5	8 meters	1
	<u>53019945</u>	Galvanized load chain - 4.8x12.5	9 meters	1
	<u>53019949</u>	Galvanized load chain - 4.8x12.5	10 meters	1
	<u>53019956</u>	Galvanized load chain - 4.8x12.5	11 meters	1
	<u>53019958</u>	Galvanized load chain - 4.8x12.5	12 meters	1
	<u>53019851</u>	Black load chain - 4.8x12.5	15 meters	1
	<u>53019860</u>	Black load chain - 4.8x12.5	18 meters	1
	<u>53019865</u>	Black load chain - 4.8x12.5	20,5 meters	1
	<u>53019862</u>	Black load chain - 4.8x12.5	20 meters	1
	<u>53019870</u>	Black load chain - 4.8x12.5	21 meters	1
	<u>53019875</u>	Black load chain - 4.8x12.5	25 meters	1
	<u>53019876</u>	Black load chain - 4.8x12.5	26 meters	1
	<u>53019877</u>	Black load chain - 4.8x12.5	100 meters	1

4. ELECTRIC STANDARD BOX

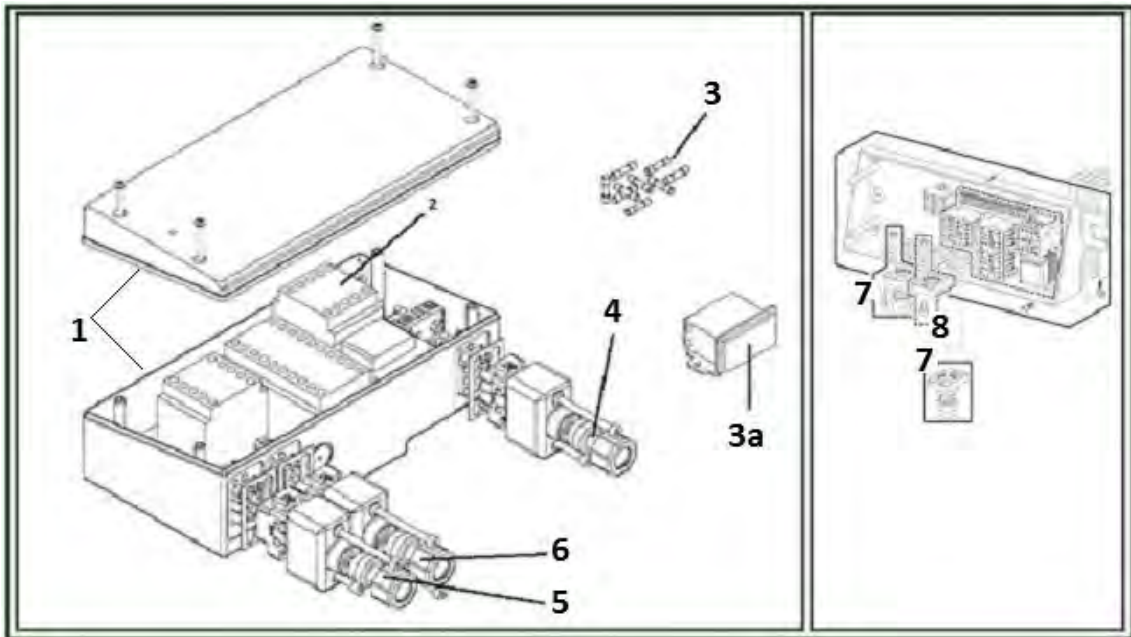

Item	Reference	Description	Observation	Quantity
1	<u>52308791</u>	Electric cubicle assembly		1
2	<u>833098</u>	Brake control module Mains switching control type	230 & 400V Steel cubicle automotive	1
2	<u>833096</u>	Brake control module Mains switching control type	500V E type hoist only	1
2	<u>52312252</u>	Electric cubicle subassy with X21 plug 2HS+2CT+2LT+ES	Equipment model C only C5 hoist only - Long	1
2	<u>52341348</u>	PC board + cubicle	400V-24V 50-60 Hz	1
2	<u>2213003</u>	PC board - 2HS+ES	230V-48V 50-60Hz	1
2	<u>2213015</u>	PC board - 2HS+ES	230V-115V 60Hz	1
2	<u>2213037</u>	PC board - 2HS+ES	690V-48V 50-60Hz	1
2	<u>2213012</u>	PC board - 2HS+ES	575V-48V 50-60Hz	1
2	<u>2213025</u>	PC board - 2HS+ES	400V-115V 50-60Hz	1
2	<u>2213013</u>	PC board - 2HS+ES	460V-48V 50-60Hz	1
2	<u>2213011</u>	PC board - 2HS+ES	500V- 48V 50-60Hz	1
2	<u>2213014</u>	PC board - 2HS+ES	460V-115V 60Hz	1
2	<u>2213004</u>	PC board - 2HS+ES	400V-48V 50-60 Hz	1
2	<u>2213018</u>	PC board - 2HS+ES - Reconnectable	230-460V-115V 60Hz	1
2	<u>2213017</u>	PC board - 2HS+ES - Standard	230-460V-115V 60Hz	1
3	<u>2219988</u>	Set of 10 fuses	48V	1
3	<u>52314754</u>	Set of 10 fuses	115V	1
3a	<u>52305692</u>	Hour counter	48V 50Hz	1
3a	<u>52305693</u>	Hour counter	48V 60Hz	1
3a	<u>52305694</u>	Hour counter	115V 60Hz	1
4	<u>2249945</u>	Push button station plug set	M+F Standard	1
5	<u>2249982</u>	Power supply plug		1
6	<u>2249946</u>	Trolley plug set	TDU - M+F Standard	1
7	<u>2249947</u>	Cable gland assembly		1
8	<u>2219814</u>	Plug cover set		1

4.1. Specific item for single phased Hoist

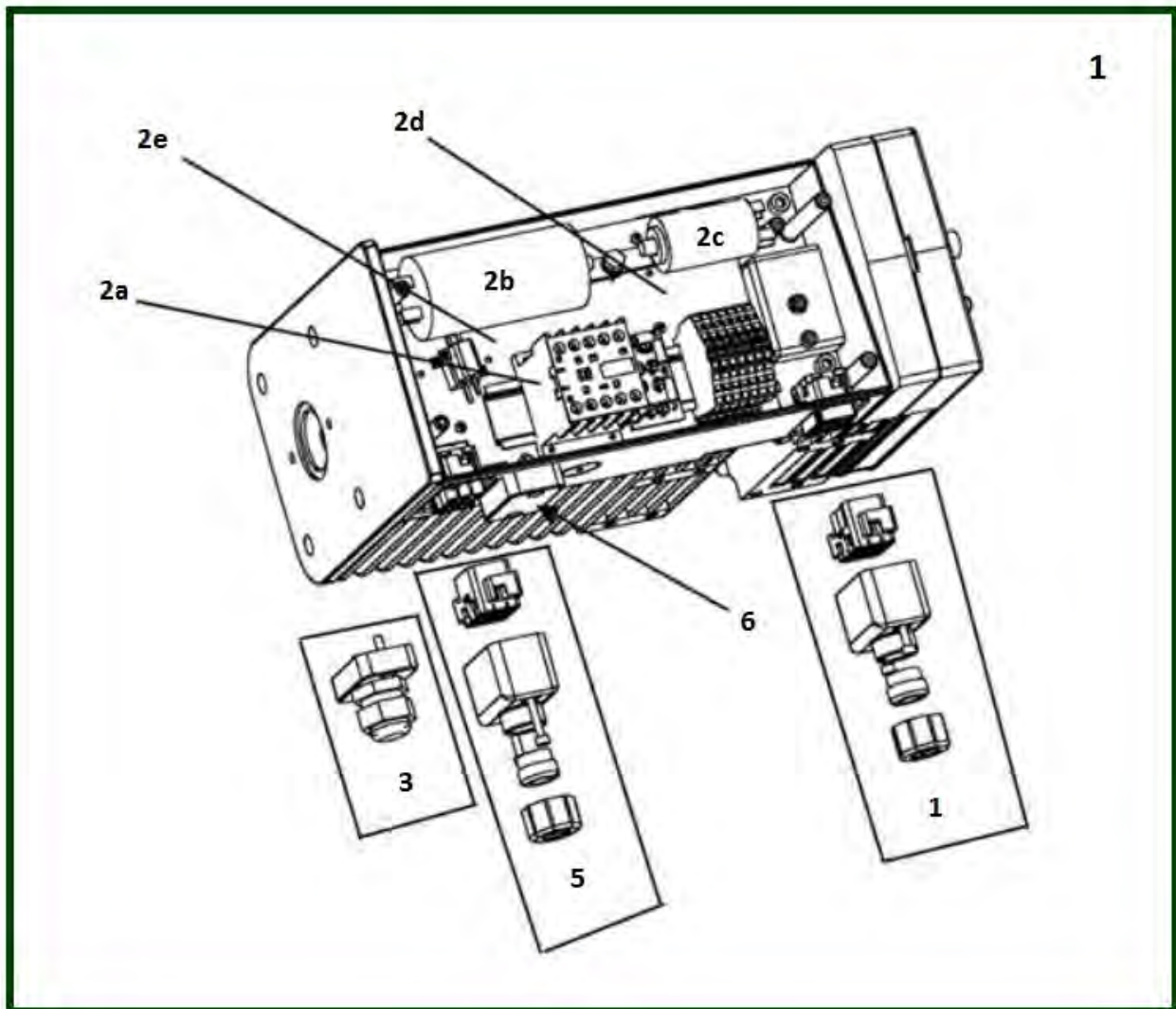

Specific item for single phased Hoist

Item	Reference	Description	Observation	Quantity
1	52308791	Electric cubicle assembly		1
2a	52314663	Main contactor KAU	115V - 50-60 Hz	1
2a	1113098	Main contactor KAU	230V - 50-60 Hz	1
2b	52309098	Contacteur	115V - 60 Hz	1
2b	52314640	Condenser 40uF Single phase	230V - 50-60 Hz	1
2c	52314641	Condenser 5uF Single phase	230V - 50-60 HZ	1
2d	2243060	Rectifier 230-400V/460V/500V/575V	C05-C25 Standard hoist or stagemaker E type hoist (direct voltage)	1
2e	52297342	Resistor 15W- 220 V Single phase	47 Ohms	1
3	2249947	Cable gland assembly		1
4	2249945	Push button station plug set	M+F Standard	1
5	2249982	Power supply plug		1
6	2219814	Plug cover set		1
-	52314707	PC board Single phase	115V 60Hz	1

5. Standard upper and lower limit switch

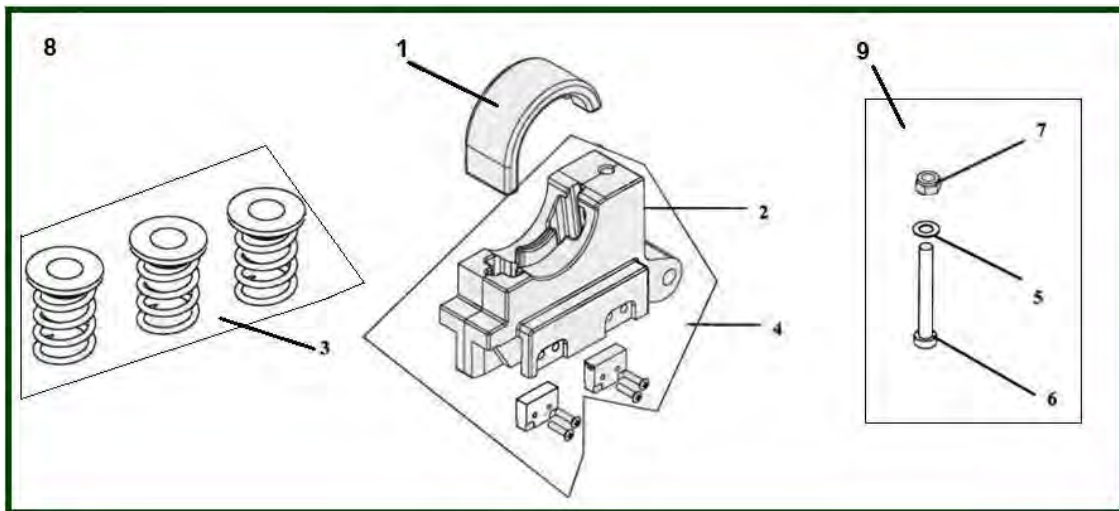

Item	Reference	Description	Observation	Quantity
1	2214011	Upper chain guide		1
2	52305493	Lower chain guide		1
3	52293583	Set of 3 springs		1
4	52305660	Lower chain guide with micro Switch		1
8	52315430	Complete Limit switch		1
9	52315431	Screw set		1
-	52341045	Limit switch set		1
-	52326175	Micro-switch standard & CSA type	After 12/2005	1

6. Cam operated limit switch - Option

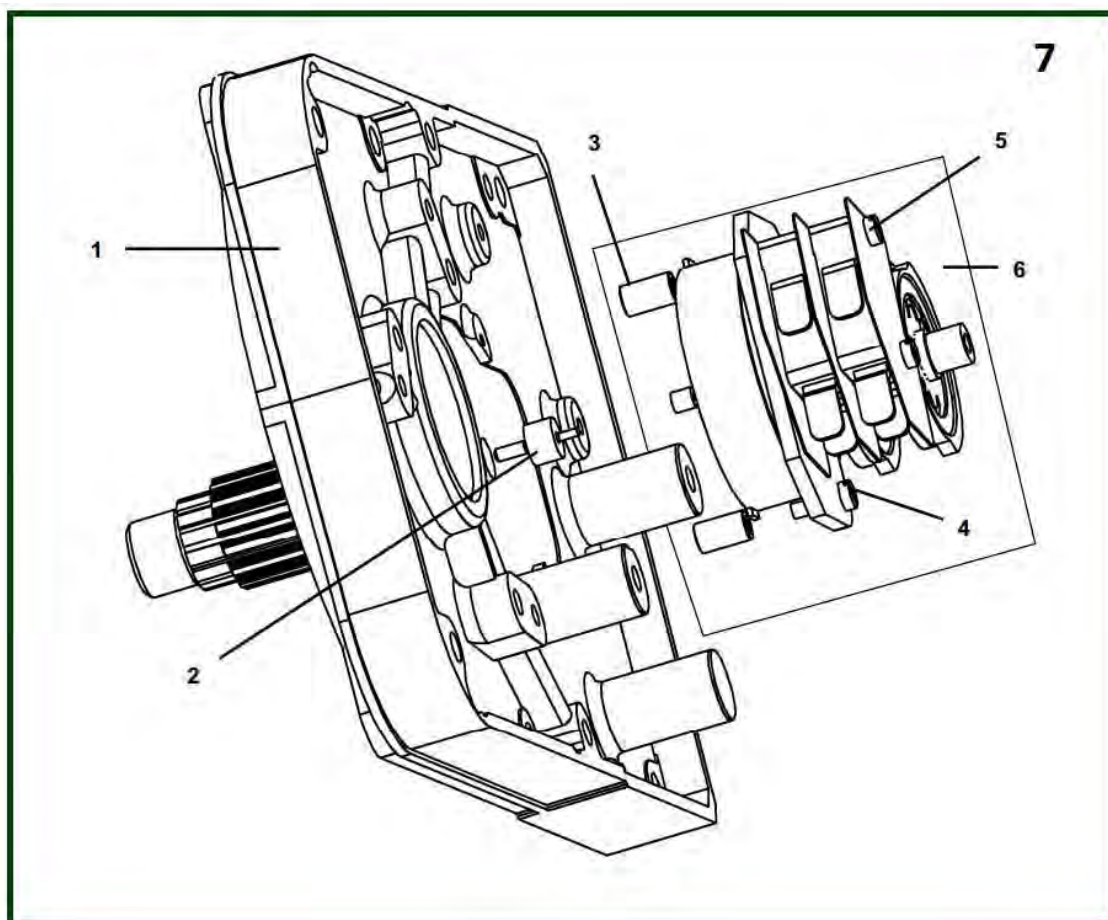

Item	Reference	Description	Observation	Quantity
1	52305505	Flange only	-	1
2	52305507	Shaft	From 8 m to 36 m	1
3	52315475	Limit switch fixing kit assembly + spacer	3+4+5	1
6	52424442	Limit switch + shaft - 2 cams	From 0 m to 8 m	1
6	52314755	Limit switch + shaft - 2 cams	From 9 m to 36 m	1
7	52868947	Complete operated limit switch - 2 cams	From 0 m to 8 m	1
7	52315474	Complete operated limit switch - 2 cams	From 9 m to 36 m	1
	52305510	Brake housing limit switch for 4 cams only		1

7. CHV TROLLEY – SINCE 2003

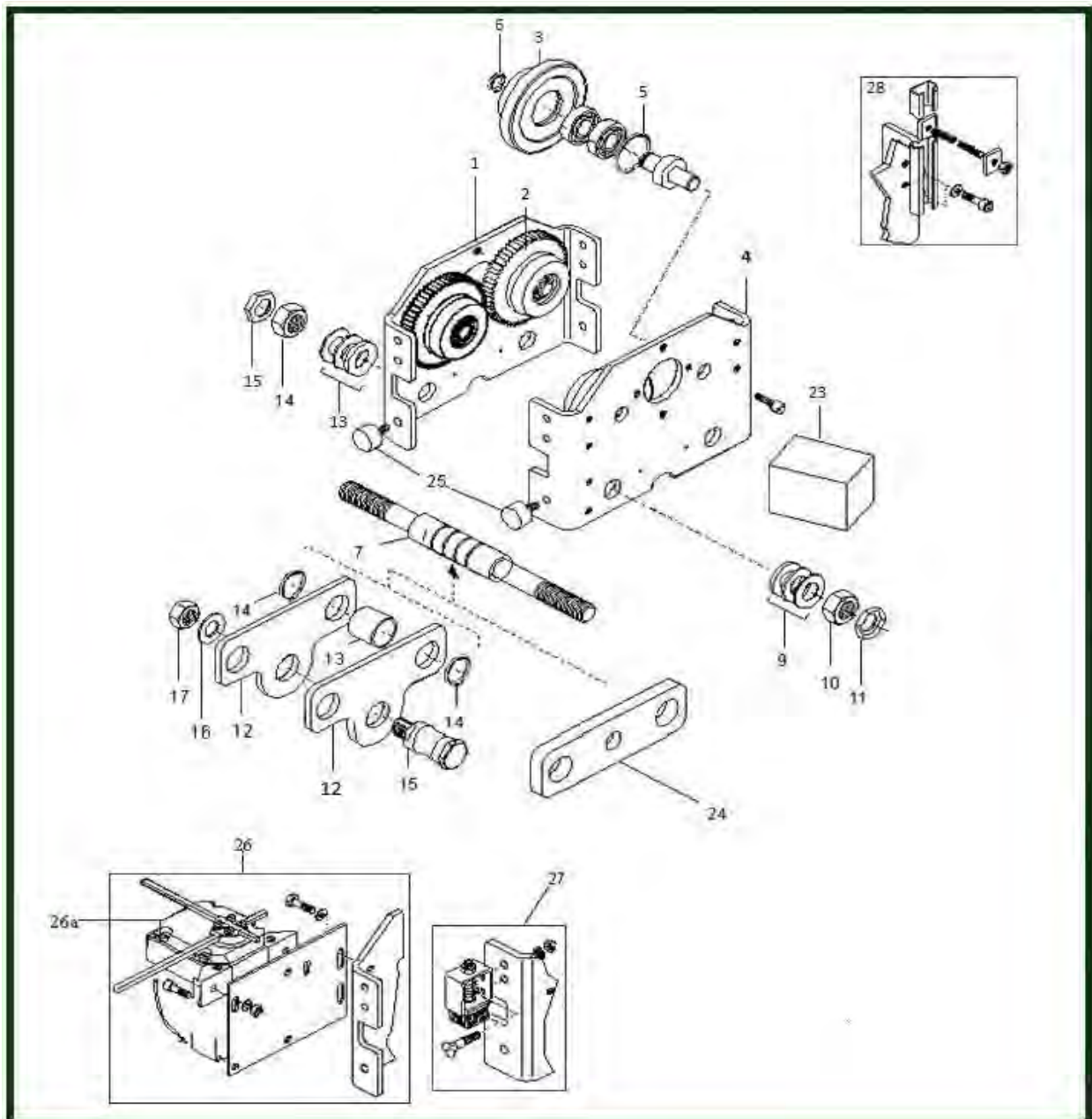

CHV TROLLEY – Since 2003

Item	Reference	Description	Observation	Quantity
1	<u>558901</u>	Side plate (drive) motor	C1	1
2	<u>558909</u>	Driving wheel assembly without shaft	C1 - Ø 62 - 93 mm	2
3	<u>558908</u>	Travel wheel assembly without shaft	C1 - Ø 62 - 93 mm	2
4	<u>558900</u>	Side plate (free) module	C1	1
6	<u>400076</u>	External circlips	C1	4
7	<u>52343304</u>	Tie rod set beam - 58 to 100 mm	C1 - Monobloc tie road since 1999	2
7	<u>52343305</u>	Tie rod set beam - 106 to 150 mm	C1 - Monobloc tie road since 1999	2
7	<u>52343306</u>	Tie rod set beam - 155 to 200 mm	C1 - Monobloc tie road since 1999	2
7	<u>52343307</u>	Tie rod set beam - 206 to 248 mm	C1 - Monobloc tie road since 1999	2
7	<u>52343308</u>	Tie rod set beam - 260 to 307 mm	C1 - Monobloc tie road since 1999	2
7	<u>52343309</u>	Tie rod set beam - 308 to 310 mm	C1 - Monobloc tie road since 1999	2
9	<u>832111</u>	Washers M20,5x40 - th : 2mm	C1	1
9	<u>832110</u>	Washers M20x40 - th : 3mm	C1	1
10	<u>831523</u>	HM Nut	C1	4
11	<u>831575</u>	Nut PAL M20	C1	4
12	<u>558940</u>	Coupling part	C1	1
13	<u>558943</u>	Sleeve	C1	2
14	<u>100051</u>	External circlips - Ø 30	VS2...O (VSX)	4
15	<u>558946</u>	Shaft de suspension	C1	1
16	<u>400762</u>	Washer	C1 - Rope Ø 12 mm	1
17	<u>831598</u>	Nylstop nut M18		1
23	<u>558907</u>	Counterweight	C1	1
24	<u>2222002</u>	Perpendicular adaptation part	C1	1
25	<u>53904973</u>	Bumper - D40x20	C1-C2-C3-C5	1
26	<u>601800</u>	Limit switch module - 2 steps	Complete assy	1
26	<u>601801</u>	Limit switch set direction	1 step	1
26a	<u>601802</u>	Limit switch - 1 step		1
26a	<u>1123046</u>	Limit switch - 2 steps		1
27	<u>7661106Q</u>	Earth brush	C1-C2-C3 - D & DA - 75 amp.	1
27	<u>5531802D</u>	Earth brush support	C1-C2-C3	1

28	<u>602910</u>	Line drive ironwork - 170 mm	<3200kg <5000kg	1
28	<u>601806</u>	Line drive ironwork - 235 mm	<3200kg <5000kg	1
28	<u>602911</u>	Line drive ironwork - 400 mm	<3200kg <5000kg	1
28	<u>601807</u>	Line drive ironwork - 435 mm	<3200kg <5000kg	1
28	<u>558997</u>	Ram for line drive ironwork 235 mm	<3200kg <5000kg	1
28	<u>558999</u>	Ram for line drive ironwork 435 mm	<3200kg <5000kg	1
-	<u>601805</u>	Limit switch	1 for 1 step - 2 for 2 steps	1
-	<u>7215453J</u>	Screw CHC 8x16	<3200kg <5000kg	2

7.1. Inverter motor TMU

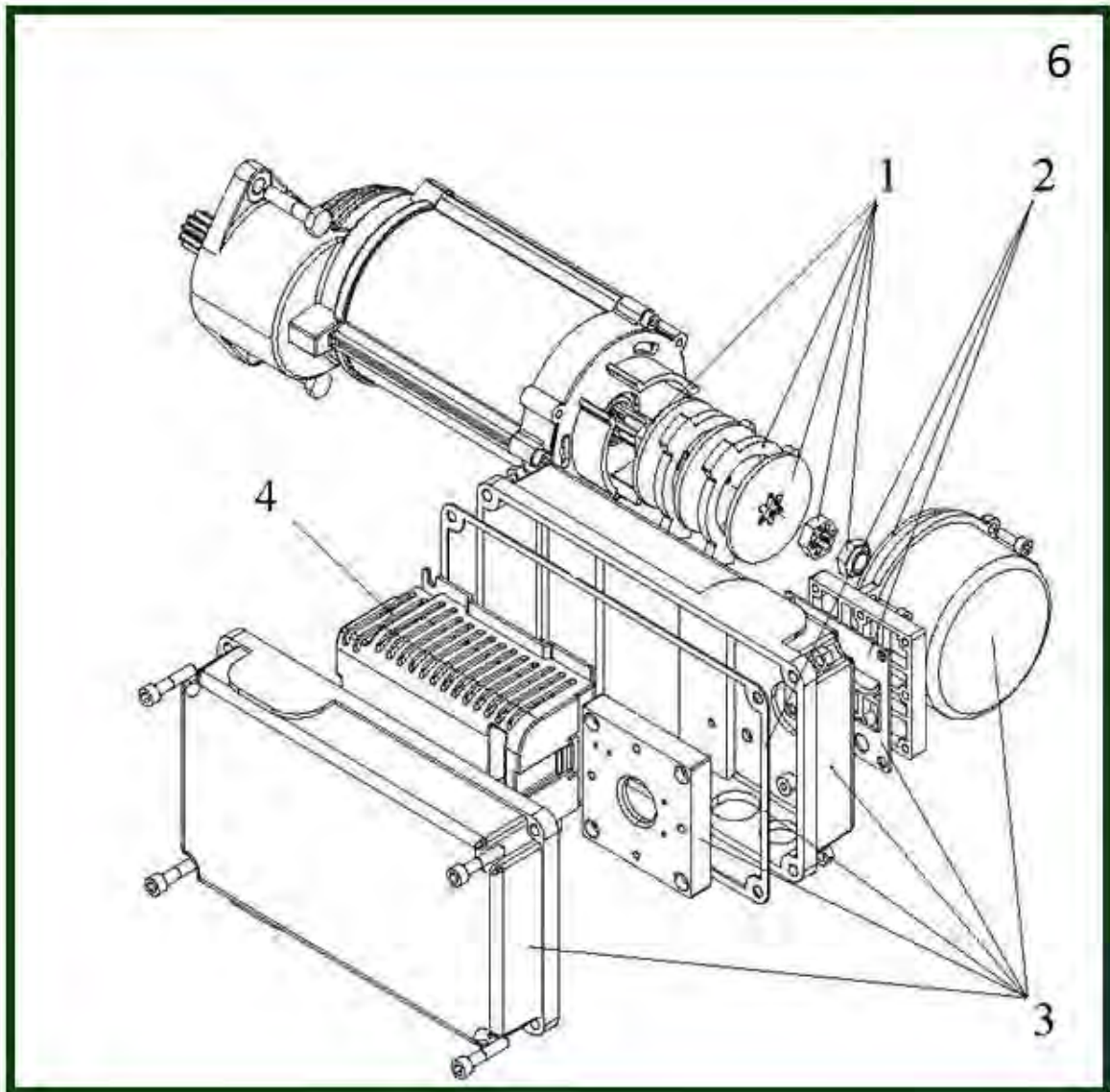

Item	Reference	Description	Observation	Quantity
1	<u>52296293</u>	Brake repair set	M06-001V	1
2	<u>52300292</u>	Sealing set	M06-008V	1
3	<u>52300291</u>	Terminal box	M06-007V	1
4	<u>52300287</u>	Inverter 48 V + filter	M06-003V	1
4	<u>52300288</u>	Inverter 115 V + filter	M06-004V	1
6	<u>52299089</u>	Motor TMU 400V/48VAC 50Hz/1T	C01 trolley only Load < = 1000 kg	1
6	<u>52304882</u>	Motor TMU 400V/48VAC 50Hz/5T	Load > 1000 kg – Short & long	1
6	<u>52299090</u>	Motor TMU 400V/115VAC 50Hz/1T	C01 trolley only Load < = 1000 kg	1
6	<u>52304881</u>	Motor TMU 400V/115VAC 50Hz/5T	Load > 1000 kg – Short & long	1
-	<u>52297959</u>	Connection Cable	CCG CELCP-04	1
-	<u>52303806</u>	Control panel	T50E-TE07	1
-	<u>52389055</u>	TMU transformer cubicle assy		1
-	<u>52833976</u>	Upgrade set		1
-	<u>52303807</u>	Transformer set	460 to 525 V --> 400 V	1
-	<u>52303808</u>	Transformer set	600 to 690 V --> 400 V	1
-	<u>52297191</u>	Reducer	GEL105PT1B0	1
-	<u>52305058</u>	Rain cover	All models C1 to C5	1

7.2. Two speeds TMU motor

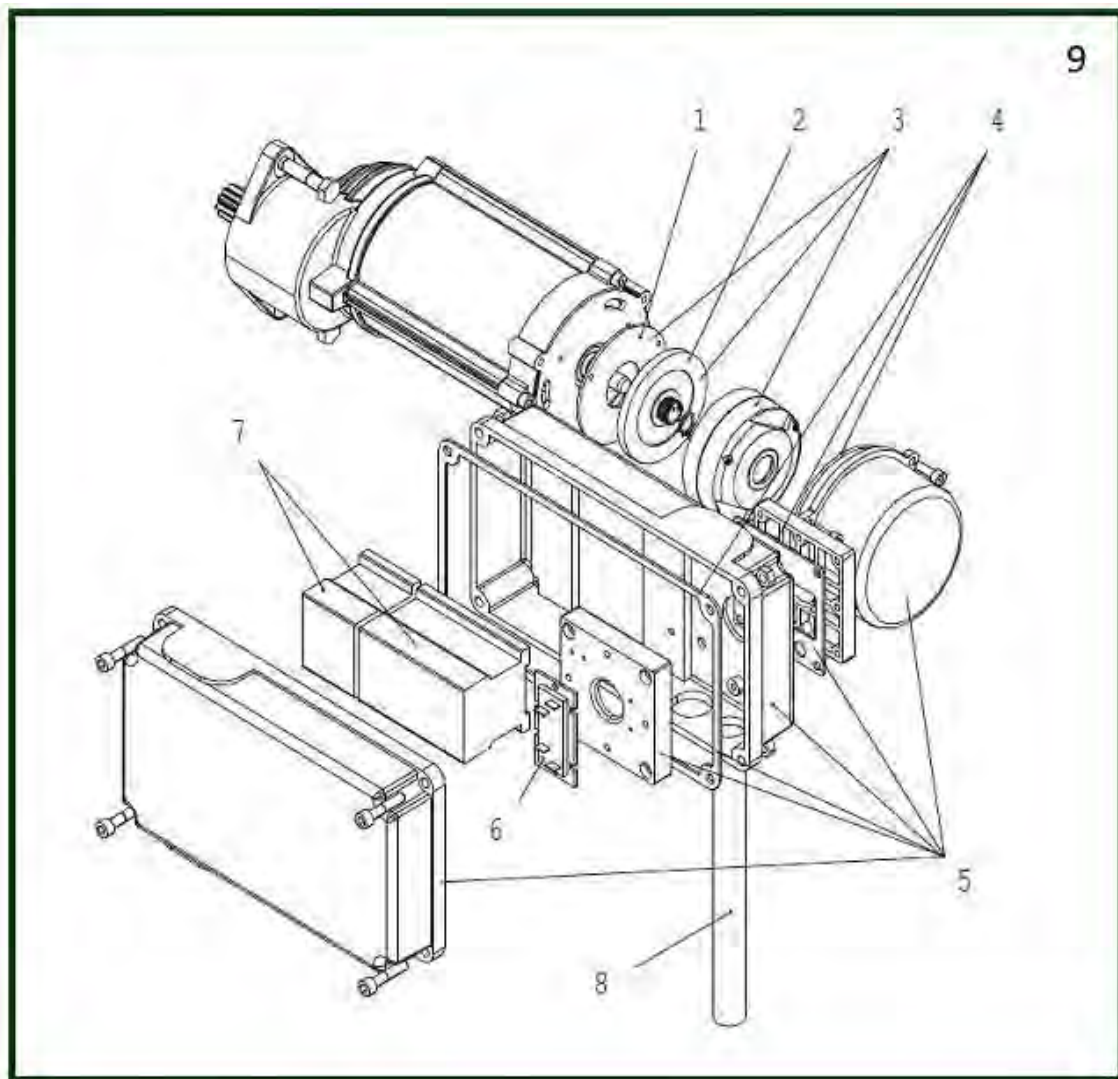

Two speeds TMU motor

Item	Reference	Description	Observation	Quantity
1	<u>52269590</u>	Friction plate		1
2	<u>52269587</u>	Brake disc		1
3	<u>52318378</u>	Brake disc 180V	MF 06MA104	1
3	<u>52318416</u>	Brake disc 240V	MF 06MA104	1
3	<u>52318424</u>	Brake disc 290V	MF 06MA104	1
4	<u>52300292</u>	Sealing set	M06-008V	1
5	<u>52300291</u>	Terminal box	M06-007V	1
6	<u>15823007</u>	Rectifier	Motor 220V	1
6	<u>15823006</u>	Rectifier	Motor 380 to 550V	1
7	<u>1113023</u>	Reversing contactor 400V/48V	LC2ECO9E (7531023V)	1
7	<u>1123052</u>	Reversing contactor	110V	1
7	<u>1113097</u>	Reversing contactor	230V	1
7	<u>1113098</u>	Main contactor KAU	230V - 50-60 Hz	1
7	<u>1113021</u>	Selector contactor	48V	1
7	<u>1123050</u>	Selector contactor	110V	1
8	<u>52297959</u>	Connection Cable	CCG CELCP-04	1
9	<u>52306137</u>	Motor TMU - 2 speeds	230V/48V/50Hz	1
9	<u>52306028</u>	Motor TMU - 2 speeds	230V/115V/60Hz	1
9	<u>52308946</u>	Motor TMU - 2 speeds	400V/48V/50Hz	1
9	<u>52308947</u>	Motor TMU - 2 speeds	500V/48V/50Hz	1
9	<u>52306027</u>	Motor TMU - 2 speeds	575V/115V/60Hz	1
9	<u>52320497</u>	Motor TMU - 2 speeds + bi metal	400V/48V/50Hz	1
-	<u>52305058</u>	Rain cover	All models C1 to C5	1

7.3. Chain travel

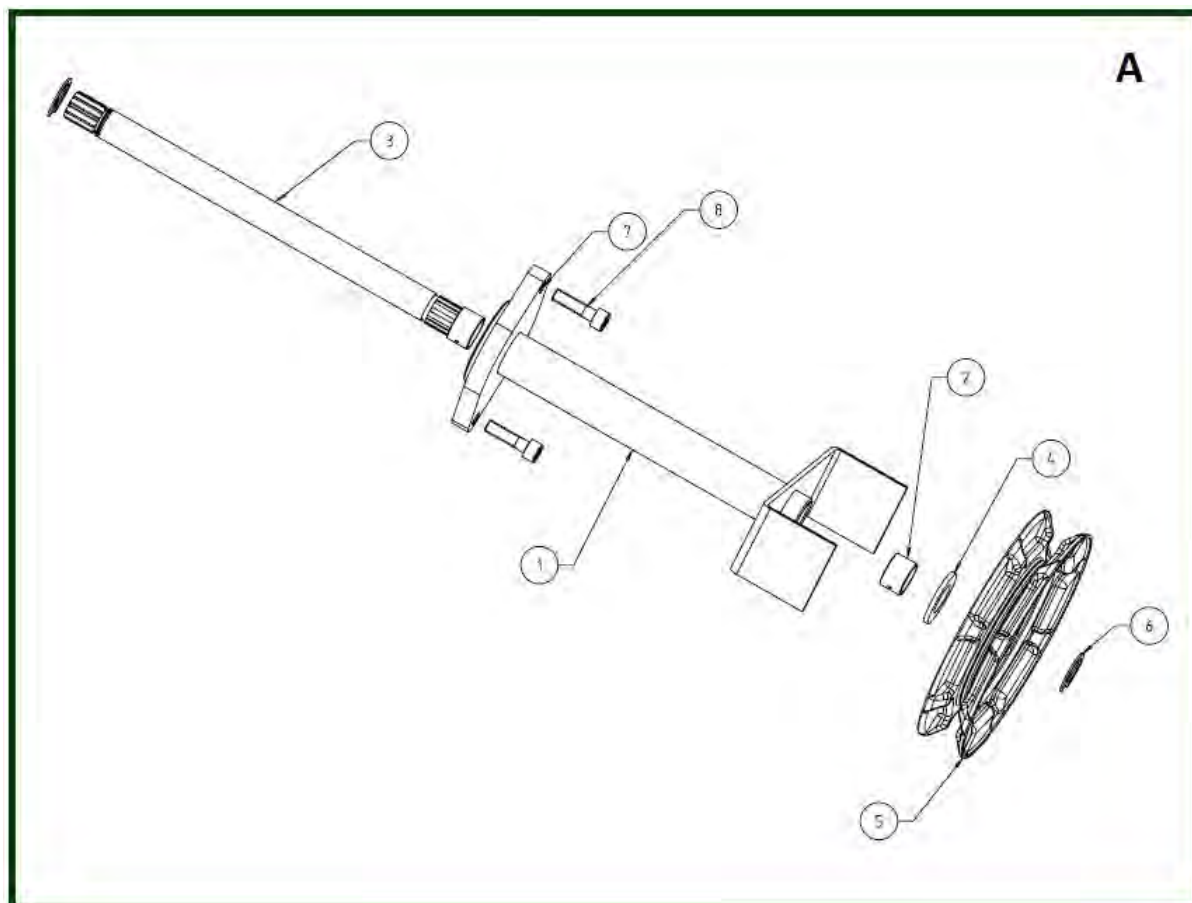

Item	Reference	Description	Observation	Quantity
1	53155221	CHM shaft		1
2	52845788	Radial sliding bearing		1
3	53155216	Axle		1
4	52294797	Plain washer	M20	1
5	52724779	Travelling hand wheel - Ø 165 mm	3,2T	1
6	52846624	Circlips D.20X1.2mm		1
7	52738485	Contact washer		1
8	52286823	Screw M8x30		1
	820003	Galvanized chain - 5x27.1		1
	53020194	Precut galvanized chain - 5x27.1	9,8 m	m
A	53155441	Chain operated manual travelling	For C1 to C5	1

7.4. Right angle motor

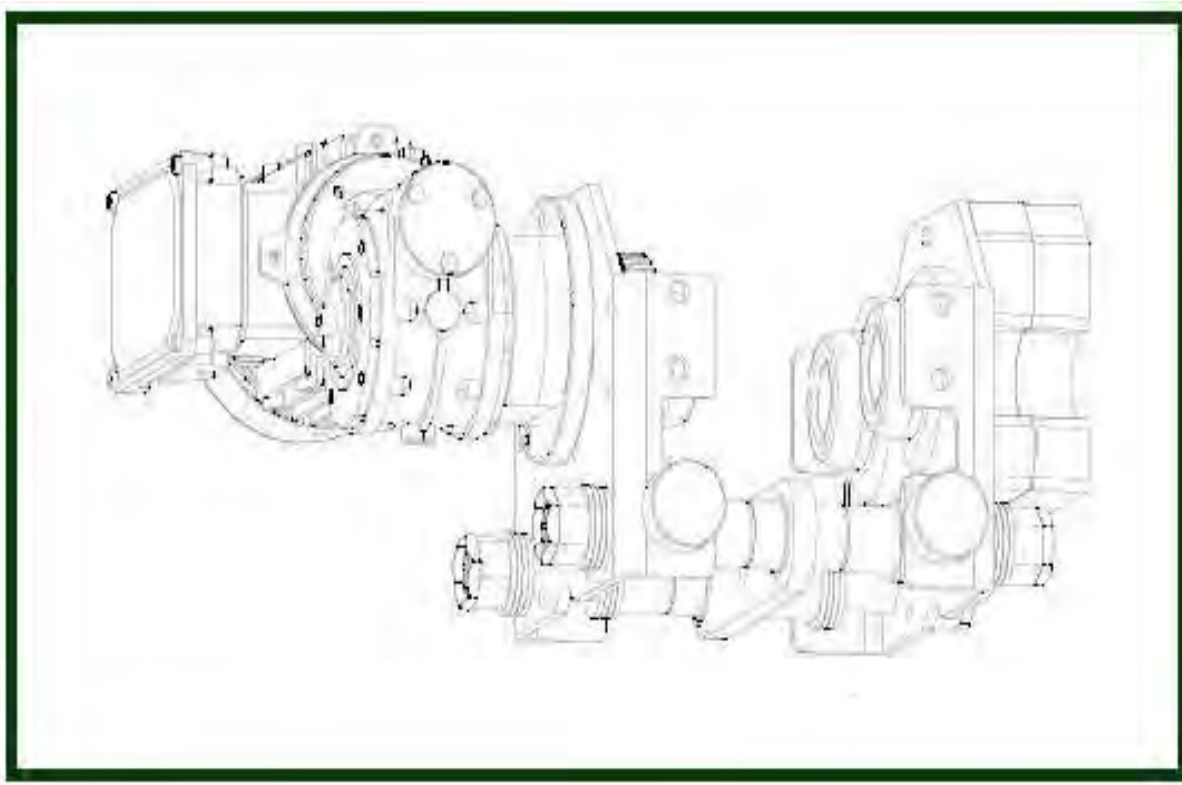

Item	Reference	Description	Observation	Quantity
	<u>551037</u>	Cubicle + Mac2 pcb		1
	<u>2216904</u>	Adaptation set for right angle travelling machinery	Pinion, flange, screws	1
	<u>556972</u>	Right angle traveling machinery	Speed 10 & 2.5m/min For C1-C2-C3	1
	<u>2133033</u>	CI board	2CT MAC	1

8. LOW HEADROOM TROLLEY – SINCE JUIN 2003

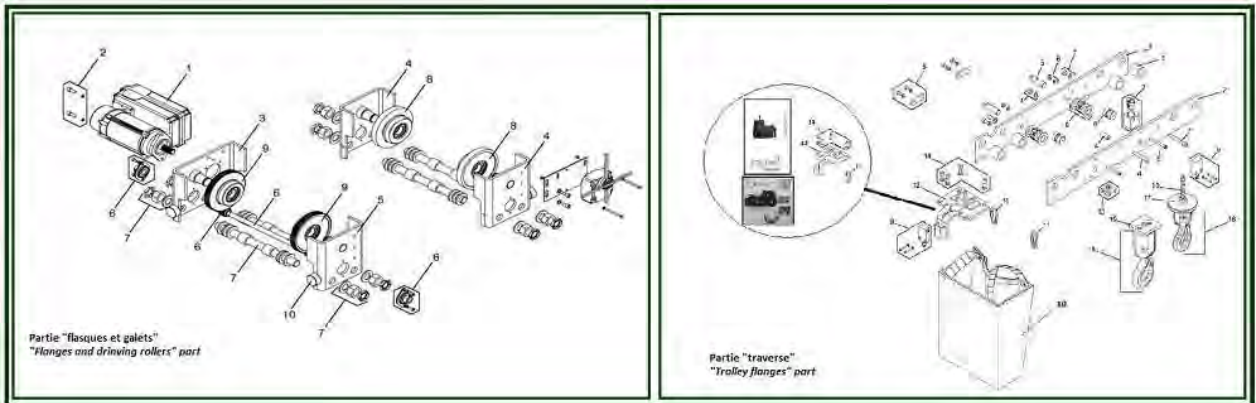

8.1. LHT trolley

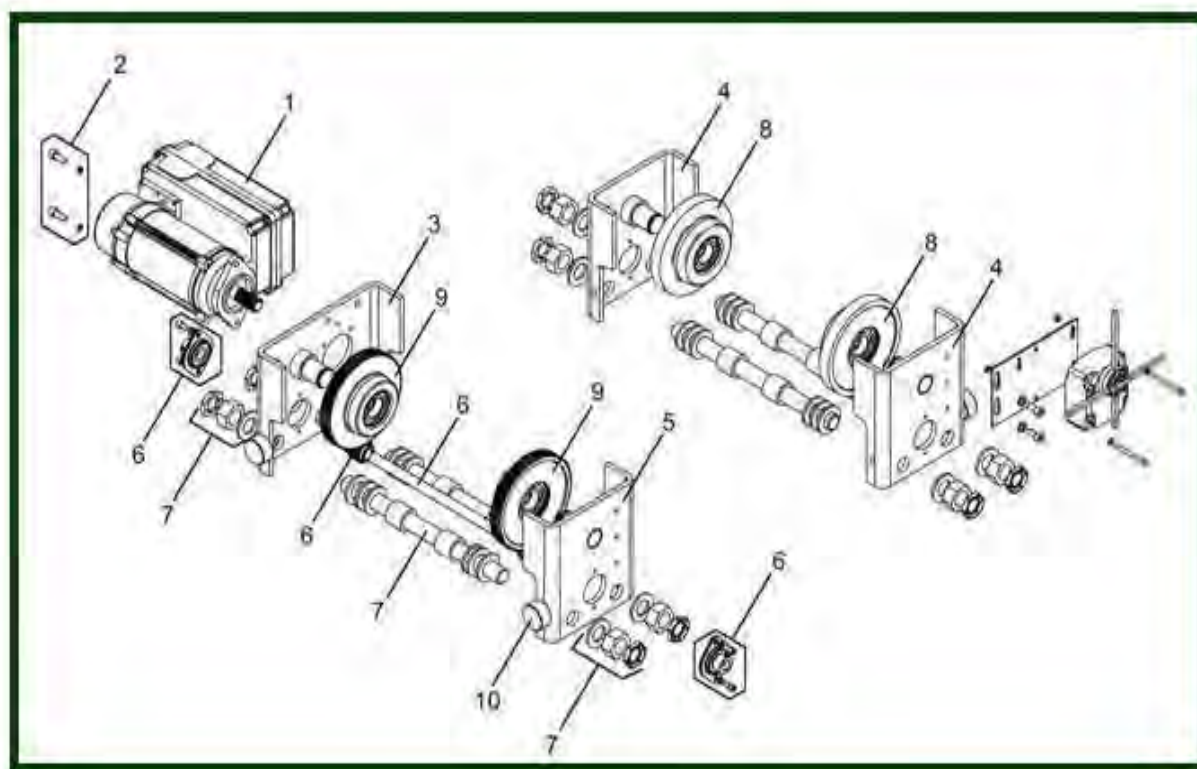

Item	Reference	Description	Observation	Quantity
2	52311193	Motor fixing screw and washer	Short & Long	2
3	52299590	Motor side flange + welded shaft		1
4 & 5	52299589	Synchro flange + welded shaft	Gear side flange (item 4) => Qty : 2 Synchro flange (item 5) => Qty : 1	1
6	52311194	Shaft assembly		1
7	556902	Kit rod	58 to 110 mm	1
7	556903	Kit rod	113 to 170 mm	1
7	556904	Kit rod	178 to 240 mm	1
7	556905	Kit rod	248 to 310 mm	1
8	558928	Travel wheel idler without shaft	C03 - C10 Ø 100x150 mm - Standard	2
9	558929	Travel wheel driving	C03 - C10 Ø 100x150 mm - Standard	2
10	558993	Rubber stopper	C02 - C03 - C05 - C10	4
-	601805	Limit switch	1 for 1 steps - 2 for 2 steps	1

8.2. Coupling cross member & lower suspension

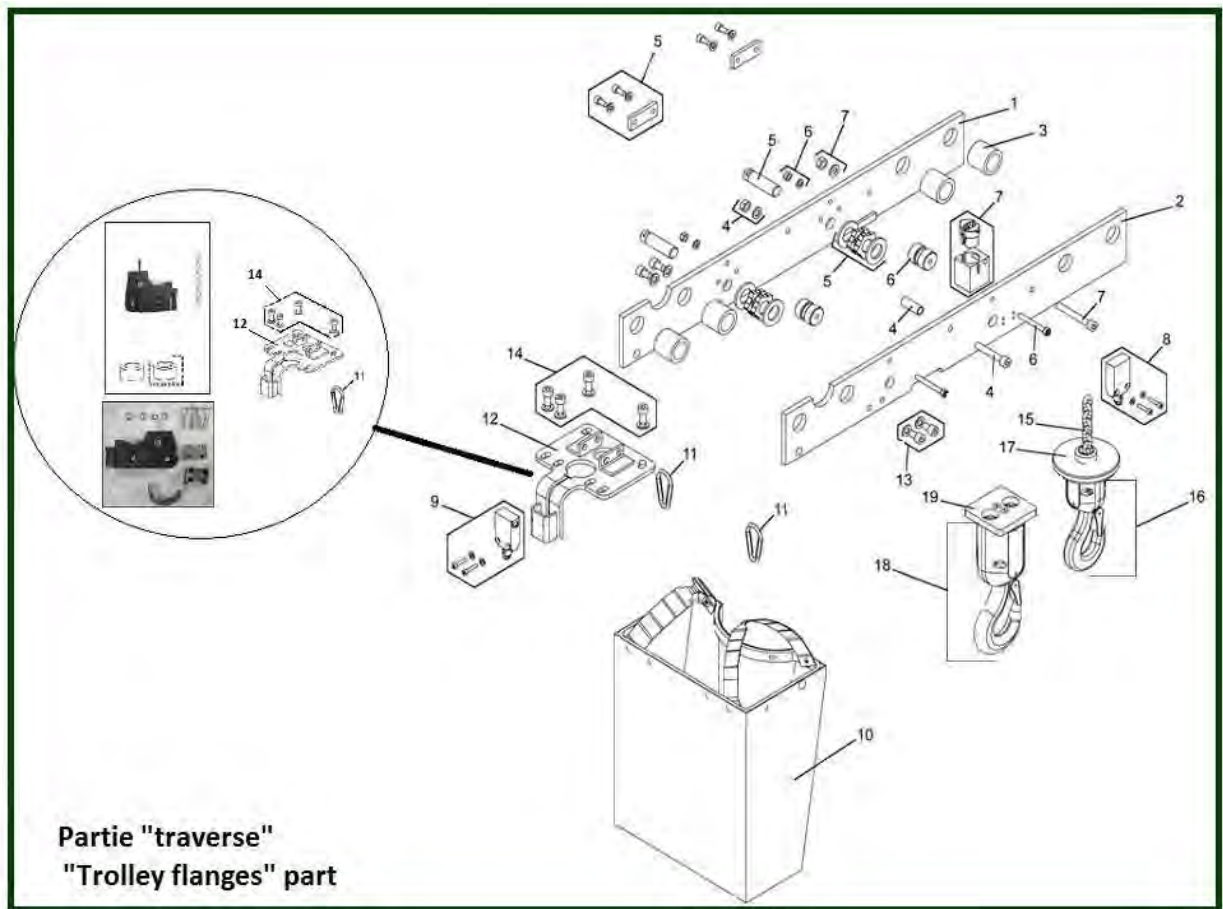

Coupling cross member & lower suspension

Item	Reference	Description	Observation	Quantity
1	<u>2214502</u>	Motor crosshead	Short	1
1	<u>2214512</u>	Motor crosshead	Long	1
2	<u>2214501</u>	Idle crosshead	Short	1
2	<u>2214511</u>	Idle crosshead	Long	1
3	<u>558968</u>	Spacer tube - Ø 35 mm	C2 – Short & Long	4
4	<u>556938</u>	Spacer tube - Ø 12 mm	Long	3
5	<u>52304652</u>	Return sprocket assembly	Short-Long	2
6	<u>52311198</u>	Diabolo set	Short = > Qty : 1 Long = > Qty :2	1
7	<u>2214506</u>	Fixed point assembly	Short-Long	1
8 & 9	<u>52311200</u>	Limit switch set - HPR		1
10	<u>52333407</u>	Chain bag	C1: 40 m - C5: 20 m With carabiner version A since May 2006	1
10	<u>52386341</u>	Chain bag	C5 : 40 m - C10 : 20 m	1
11	<u>830870</u>	Chain bucket fixing	Short-Long	2
12	<u>52336084</u>	Hoist support plate + lower plastic guide	Short-Long	1
13	<u>52311201</u>	Plate and crossmember mounting assembly	Short-Long	1
14	<u>52311202</u>	Hoist fixing set	Short-Long	1
15	<u>2213500V</u>	Galvanized load chain - 4.8x12.5		1
16	<u>2219902</u>	Lower hook block assembly	1 fall - Short-Long	1
17	<u>556939</u>	Counterweight for hook	1 fall – Short-Long	1
18	<u>2219903</u>	Lower hook block assembly standard	2 falls – Short-Long	1
19	<u>52311204</u>	Counterweight for hook	2 falls – Short-Long	1
-	NC F AG	Brake with fittings	Not supplied anymore replaced by 52309591	1
-	<u>601805</u>	Limit switch	1 for 1 steps - 2 for 2 steps	1

8.3. Flanges adjustments

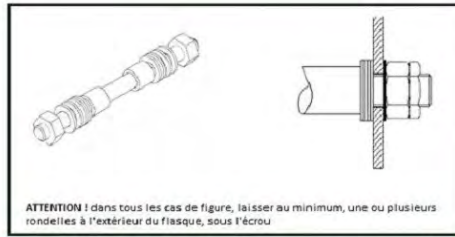

Largeur de fer	Longueur des tirants M24	Quantité + Longueur des bagues de réglage*	Quantité de rondelle*	
			ep 4 mm	ep 2mm
58	260mm	2 x 32mm	2	2
64			4	1
66			4	2
72			6	1
73			6	2
74			6	2
81			8	2
82			8	2
89			10	2
90			10	2
91			10	3
98			12	2
100			12	3
106			14	2
108	14	3		
110	16	0		
113	325mm	4 x 32mm	0	1
118			2	0
119			2	0
120			2	1
125			2	3
126			4	0
131			4	2
133			6	0
135			6	1
137			6	1
140			6	3
143			8	0
146			8	2
147			8	3
149	8	3		
150	10	0		
155	10	2		
158	12	0		
160	12	1		
166	14	0		
168	14	1		
170	14	2		
178	390 mm	2 x 96 mm + 2 x 32 mm	0	2
180			0	3
185			2	1
186			2	2
188			2	3
190			4	0
198			6	0
200			6	1
206			8	0
210			8	2
215			10	0
218			10	2
220			10	3
226			12	2
240	16	1		
248	2	1		
260	4	3		
268	6	3		
280	10	1		
288	12	1		
300	14	3		
302	16	0		
303	16	1		
304	16	1		
305	16	2		
306	16	2		
307	16	3		
308	16	3		
309	18	0		
310	18	0		

* Quantité de rondelles à répartir de chaque côté du tirant

8.4. Travelling machinery 1 & 2 – Variation speed

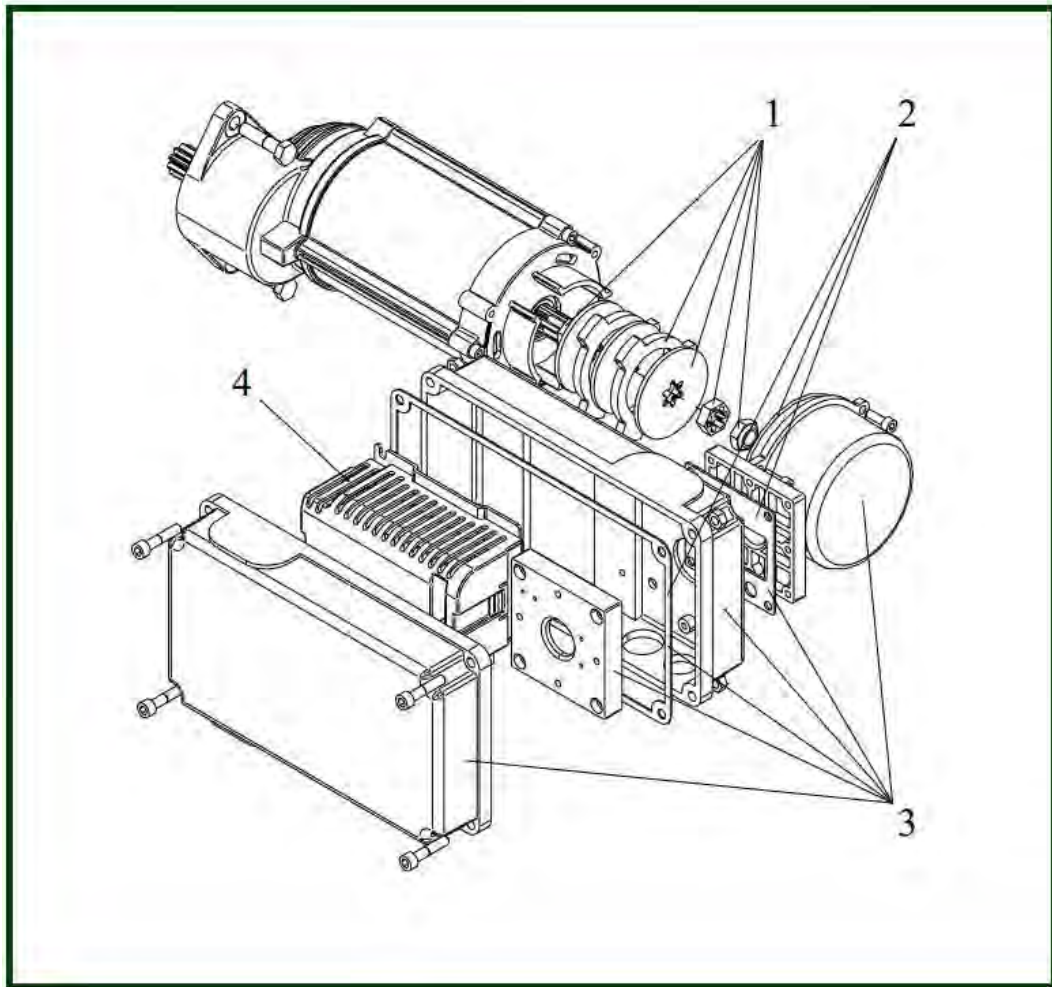

Item	Reference	Description	Observation	Quantity
1	52296293	Brake repair set	M06-001V	1
2	52300292	Sealing set	M06-008V	1
3	52300291	Terminal box	M06-007V	1
4	52300287	Inverter 48 V + filter	M06-003V	1
4	52300288	Inverter 115 V + filter	M06-004V	1
-	52297959	Connection Cable	CCG CELCP-04	1
-	52304882	Motor TMU 400V/48VAC 50Hz/5T	Load > 1000 kg - Short & long - C10	1
-	52304881	Motor TMU 400V/115VAC 50Hz/5T	Load > 1000 kg - Short & long - C10	1
-	52297191	Reducer	GEL105PT1B0	1

8.5. Travelling machinery – Two speeds

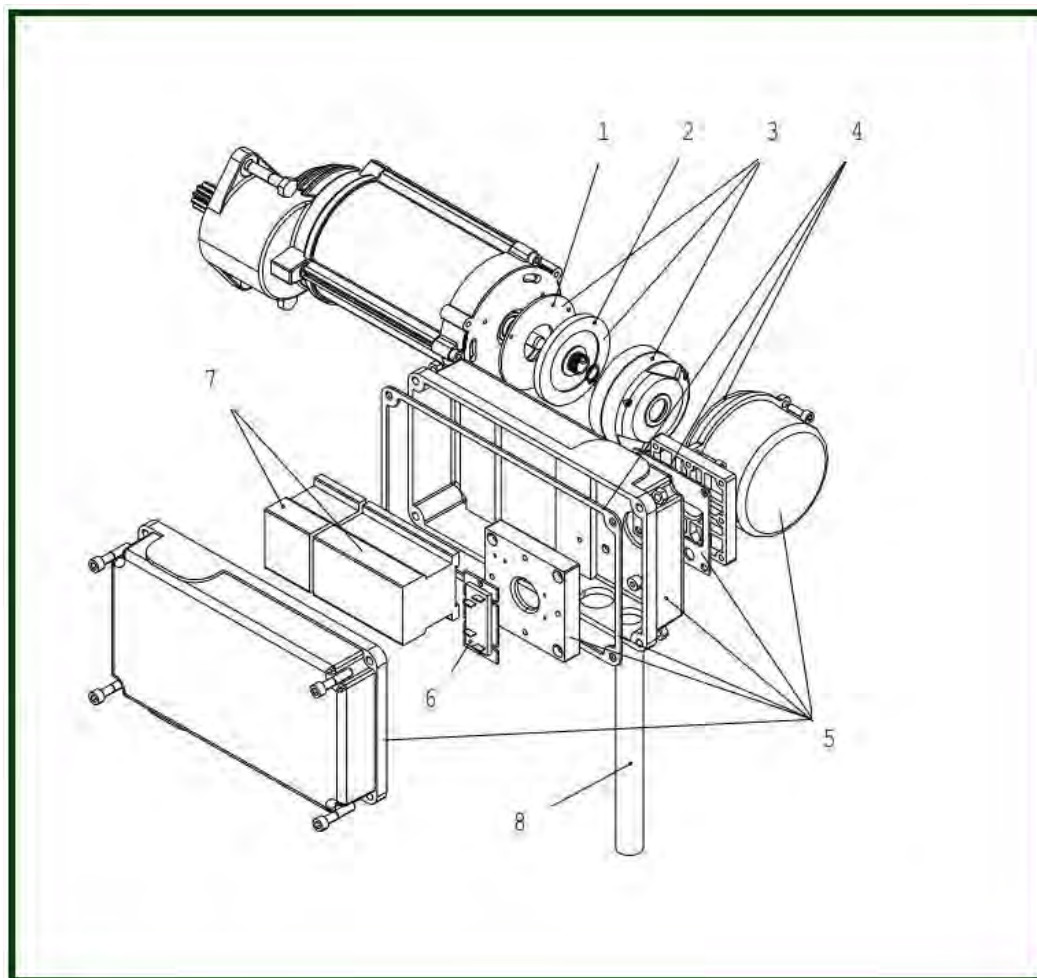

Item	Reference	Description	Observation	Quantity
1	52269590	Friction plate		1
2	52269587	Brake disc		1
3	52269582	Brake disc 180V	MF 06MA104	1
3	52269583	Brake disc 240V	MF 06MA104	1
4	52300292	Sealing set	M06-008V	1
5	52300291	Terminal box	M06-007V	1
6	60010152	Brake control module	NM181NR2V	1
6	60003169	Brake control module	NM181NR4V	1
7	52306792	Reversing contactor - 48V	M06-010V	1
7	52306794	Reversing contactor - 110V	M06-011V	1
7	52306795	Selector contactor - 230V	M06-012V	1
8	52297959	Connection Cable	CCG CELCP-04	1