

# TIRLIFT 2

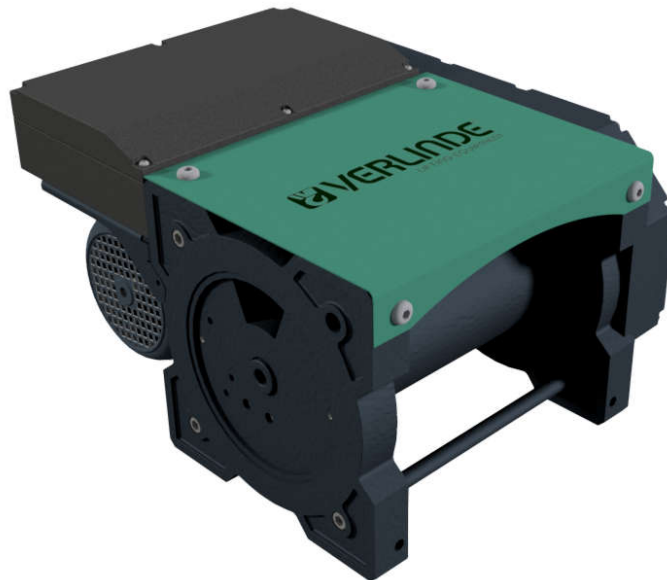

---

Owner's Manual

---

**Electric winches**

**250 to 1500 kg**

**Contents**

1. Conditions of use .....	p. 3
2. Safety instructions.....	p. 4
3. Warranty .....	p. 5
4. Reception of the equipment .....	p. 5
5. Obligatory regulatory checks by the user .....	p. 6
6. Presentation of the machines.....	p. 7
6.1 Technical description	
6.2 Operation	
6.3 Available models	
6.4 Dimensions and fastenings	
6.5 Accessories	
6.6 FEM classification	
6.7 Variable speed drive	
7. Handling – Storage .....	p. 14
8. Assembly and start-up .....	p. 14
8.1 Securing the winch	
8.2 Wire rope exits	
8.3 Change to initial assembly	
8.4 Set-up	
8.5 Electrical connections	
9. Servicing and maintenance.....	p. 25
9.1 Winches	
9.2 Ropes	
9.3 Hooks	
9.4 Brake	
10. Taking out of use .....	p. 27
11. Spare parts .....	p. 28
12. Operating faults.....	p. 29
13. Tests.....	p. 30
14. Declaration of EC conformity.....	p. 30
15. Appendices .....	p. 32

## 1 - Conditions of use

All users must read the set-up instructions carefully before using the product for the first time. These instructions should enable the user to familiarise themselves with the winch and use it to its full capacity. The set-up instructions contain important information about how to use the winch safely and correctly. Compliance with these instructions helps to avoid danger, reduce repair costs, reduce stoppage time and improve the reliability and service life of the winch. The instruction manual must always be available in the place where the winch is being used. In addition to the set-up instructions and regulations concerning the prevention of accidents, the work safety and professional regulations in force in each country must also be respected.

This equipment is governed by European regulations and more specifically Directive 2006/42/EC on machinery, EMC Directive 2004/108/EC and LVD 2006/95/EC, as well as the EN 14492/1 standard.

These winches are designed to move loads using a suitable steel rope. They have been designed to perform lifting and pulling operations within the defined load capacity limit and with safety factor 5 (static against sudden failure).

- For use in lifting, the European regulation makes certain equipment obligatory, such as a limit switch system and, for loads of 1,000 kg or more, a load limiter.
  - The operator must check the presence of this equipment (available as an option from the manufacturer) before using the product for lifting purposes.
  - The capacity indicated on the winch corresponds to the maximum capacity of use (MCU); in no event should this capacity be exceeded.
  - **THIS WINCH CAN UNDER NO CIRCUMSTANCES BE USED TO LIFT PEOPLE.**
  - Do not begin moving the load until you have attached it correctly and checked that all personnel are outside the danger zone.
  - Before use, the operator must always check that the machine, rope, hook, markings and moorings are in good working order.
  - The operator must check that the load is attached in such a way that the winch, the rope and the load place neither the operator nor any other person is in danger.
  - The winches can be used at ambient temperatures ranging from -10°C to +50°C. Please consult the manufacturer in the event of extreme conditions of use.
- Important: In the event of an ambient temperature below 0°C, the brake must be tested to ensure that there are no operating faults resulting from the freezing conditions.
- The data concerning the heat-resistance of the steel rope and its fastenings must be available on request from the manufacturer and must be respected.
  - VERLINDE cannot accept any liability for the consequences resulting from the use or installation of equipment not provided for in the present instructions or for the consequences of removal, modification or replacement of original parts or components with parts or components from other sources without the written agreement of VERLINDE.
  - The use of winches requires strict compliance with the accident prevention and safety measures in force in the country where they are used.

**YOU MUST ALSO RESPECT THE REGULATIONS APPLICABLE IN YOUR COUNTRY.**

## 2 - Safety instructions

Before using the equipment, check that there are no causes of overloading such as: adhesion to the ground, suction, jamming, etc. of the load.

As the operator of the winch, you are responsible for your own safety and the safety of your colleagues in the work zone of the machine.

The operator must respect all the following safety information, without exception, concerning the handling and operation of the winch as well as the references to other sections of this instruction manual. Failure to comply with these instructions increases the level of risk.

- Only the people designated by the company are authorised to operate the winch
- Before using the winch for the first time, familiarise yourself with its conditions of use. To this end, read the present instruction manual carefully and in its entirety and perform all the operations described herein one after the other.
- Inform your departmental manager or the safety officer of any malfunction so that the fault can be repaired immediately.
- Respect the directives of the industrial accident prevention organisations such as, in France, the Caisse Régionale d'Assurance Retraite et de la Santé au Travail (C.A.R.S.A.T.) and the Health and Safety Committee (HSC) of your company, if one exists.
- Scrupulously respect all information in the sections concerning the CONDITIONS OF USE (section §1) and the WORK ROPE (section §8.5.4).
- The operator(s) must have an unimpeded view of the load.
- Please ensure that the operator is qualified to operate the machine in the conditions provided for in this manual. This will ensure the safety of both people and the environment.
- Do not lift or transport loads when there are personnel inside the danger zone.
- Do not authorise the personnel to walk under a suspended load.
- Do not leave a load suspended or with the rope taut unsupervised.

In addition to the above instructions, we must warn you against all incorrect use or handling listed below. **It is dangerous and prohibited to:**

- **unwind the drum completely (keep 2 to 3 residual windings).**
- **pull at an angle.**
- **swing the load.**
- **use ropes of a different diameter and texture to those specified in this instruction manual (FEM 1 Am – ISO M4 for 250 and 600 kg, FEM 1 Bm – ISO M3 for 350, 500, 800, 990 and 1500 kg).**
- **use damaged ropes or ropes with splices.**
- **grab or touch a moving rope or a rotating drum.**
- **use hooks without a latch, which do not correspond to the loads indicated on the winch or which are in poor condition.**
- **insert objects into moving parts.**
- **work on loaded winches or when the rope is taut.**
- **use the winch rope as a towing chain.**
- **drum on the control box (overheating of the motor and electrical equipment).**
- **Place hands or clothes, etc. in contact with moving parts, in particular the areas where the rope is wound in/out.**



### **3 - Warranty**

Our electric winches are guaranteed for 2 years from the date of shipment (ex-works). The seller undertakes to repair any operating fault resulting from a fault in the design, execution, components or materials themselves.

The warranty does not cover wear and tear or damage resulting from a lack of regular or periodic maintenance. It does not cover damage resulting from a lack of supervision, incorrect handling or an incorrect use of the machines, in particular overloading, pulling at an angle, under or overvoltage or incorrect connection.

The warranty does not apply to any disassembly, modification or replacement of mechanical or electrical parts undertaken without our agreement or by a non-approved operator. The warranty only applies to the manufacturer's original spare parts. During the warranty period, the seller must replace or repair any parts recognised as faulty after inspection by the qualified and approved department, all free of charge.

The warranty excludes all other services or compensation.

Repairs undertaken within the scope of the warranty are, in principle, performed in the seller's workshops or the workshop of a representative approved by the manufacturer. When work is carried out on the equipment outside of their workshops, the seller must cover the labour costs related to the disassembly or reassembly of these parts if these operations are performed exclusively by their personnel or a representative approved by the manufacturer. The parts replaced become the property of the seller and must be returned to them at their own expense.

In the case of components with a particular relative importance not manufactured by the seller themselves and which bear the brand of a specialist manufacturer, the warranty, which may vary according to the manufacturer, is the same as that agreed by this manufacturer.

### **4 - Reception of the equipment**

- Make a visual inspection of the packaging to ensure that it is in good condition.
- In the event of a problem, issue the usual reserves.
- Check that the winch corresponds to your order.

## 5 - Obligatory regulatory checks by the user

The users are required to comply with the standards in force in their country.

With regard to France:

Order of 1<sup>st</sup> March 2004 relating to the verification of lifting machines and accessories:

The modifications to the regulation relating to the use and verification of lifting machines and accessories, which came into effect on 1<sup>st</sup> April 2005, impose new obligations on all users:

- The suitability inspection that involves checking that the lifting machine is suitable for the work that the user intends to carry out, as well as for the risks to which workers are exposed, and that the intended operations are compatible with the conditions of use for the machine defined by the manufacturer.
- The assembly and installation inspection that involves ensuring that the lifting machine is assembled and installed safely in accordance with the manufacturer's instruction manual,
- The general periodic visits that involve an inspection of the state of preservation and the operating tests.
- The commissioning or recommissioning inspections in the event of a change in the place of use, the configuration or the conditions of use on the same site; following the disassembly and subsequent reassembly of the lifting machine; after any major replacement, repair or transformation concerning the essential components of the lifting machine; or following any accident caused by the failure of an essential component of the lifting machine.
- The maintenance booklet (order of 2<sup>nd</sup> March 2004 applicable from 1<sup>st</sup> April 2005) which must be used to record the maintenance operations carried out in accordance with the recommendations of the manufacturer of the machine as well as any other inspection, maintenance operation, repair, replacement or modification carried out on the machine. For each operation, it is essential to record the date of the work, the names of the people and, where appropriate, the companies which carried out the work, the nature of the operation and, if it is a periodic operation, the frequency. If the operations involve the replacement of certain components of the machine, the references of these components are indicated.

The inspections must be carried out in accordance with a protocol and are intended to ensure preventive maintenance aimed at detecting any damage or defect liable to cause a hazard.

## 6 - Presentation of the machines

TIRLIFT 2 winches are lifting and pulling machines manufactured according to the standards and regulations in force.

### 6.1 Technical description

All versions

- Rigid steel and cast aluminium structure.
- Mechanically welded steel drum with wide flanges for safe and rational fastening of the rope.
- Single or three phase asynchronous motors.
- Watertight reducer in oil bath with helical gears.
- Single or three-phase standard power socket.
- Emergency stop as standard.
- Optional: integrated end limit switch.

Low Voltage versions only:

- 24 V or 190 V direct control electromagnetic brake.
- Electrical equipment under watertight cover.
- Very low voltage, 24 V remote control with socket – IP 65.
- 220/380 V three-phase control – IP 55 double insulation.

Speed variation versions only:

- 190 V direct control electromagnetic brake.
- Electrical equipment under watertight cover.
- Very low voltage, 24 V remote control – IP 65.

### 6.2 Operation:

The load and winding speed of the rope on the drum are obtained by reducing the rotation movement of the electric motor via a shaft mounted helical gear unit.

Outside the motor's operating phases, a mechanical automatic brake stops and keeps the load in position.

The brake for the speed variation and Low Voltage versions is independent and is electrically controlled.

In Low Voltage version, the motor is controlled on and off using a three-button wired remote control (up/down/emergency stop).

In the speed variation version, the motor rotation speed is adjusted using a potentiometer on the remote control. The acceleration and deceleration phases are managed by the machine to prevent sudden starts and stops (and progressive).

### 6.3 Available models

SWL (kg)	Type	Group	Motor type	Rope capacity	Motor power (kW)	Speed (m/min)	Speed type	Rope diameter
125	TC121M	2m	3 phases	56	0,75	21	1 speed	5
	TL121M	2m	3 phases	81	0,75	21	1 speed	5
	TC121MM	2m	1 phase	56	0,75	21	1 speed	5
	TL121MM	2m	1 phase	81	0,75	21	1 speed	5
250	TC221M	1Am	3 phases	56	1,1	21	1 speed	5
	TL221M	1Am	3 phases	81	1,1	21	1 speed	5
	TC214M	1Am	3 phases	56	0,75	14	1 speed	5
	TL214M	1Am	3 phases	81	0,75	14	1 speed	5
	TC209M	1Am	3 phases	56	0,75	9	1 speed	5
	TL209M	1Am	3 phases	81	0,75	9	1 speed	5
	TC260V	1Am	3 phases	56	3VV	60	Variation	5
	TL260V	1Am	3 phases	81	3VV	60	Variation	5
	TC243VM	1Am	1 phase	56	2,2VV	43	Variation	5
	TL243VM	1Am	1 phase	81	2,2VV	43	Variation	5
	TC243VT	1Am	3 phases	56	2,2VV	43	Variation	5
	TL243VT	1Am	3 phases	81	2,2VV	43	Variation	5
	TC221MM	1Am	1 phase	56	1,1	21	1 speed	5
	TL221MM	1Am	1 phase	81	1,1	21	1 speed	5
	TC214MM	1Am	1 phase	56	0,75	14	1 speed	5
	TL214MM	1Am	1 phase	81	0,75	14	1 speed	5
	TC209MM	1Am	1 phase	56	0,75	9	1 speed	5
	TL209MM	1Am	1 phase	81	0,75	9	1 speed	5
	TC221VM	1Am	1 phase	56	1,1 VV	21	Variation	5
	TL221VM	1Am	1 phase	81	1,1 VV	21	Variation	5
	TC221VT	1Am	3 phases	56	1,1 VV	21	Variation	5
	TL221VT	1Am	3 phases	81	1,1 VV	21	Variation	5
	TC214VM	1Am	1 phase	56	0,75VV	14	Variation	5
	TL214VM	1Am	1 phase	81	0,75VV	14	Variation	5
	TC214VT	1Am	3 phases	56	0,75VV	14	Variation	5
	TL214VT	1Am	3 phases	81	0,75VV	14	Variation	5
	TC221B	1Am	3 phases	56	0,37/1,1	6/21	2 speed	5
	TL221B	1Am	3 phases	81	0,37/1,1	6/21	2 speed	5
	TC214B	1Am	3 phases	56	0,37/1,1	4/14	2 speed	5
	TL214B	1Am	3 phases	81	0,37/1,1	4/14	2 speed	5

SWL (kg)	Type	Group	Motor type	Rope capacity	Motor power (kW)	Speed (m/min)	Speed type	Rope diameter	
500	TC521M	1Bm	3 phases	42	2,2	21	1 speed	7	
	TL521M	1Bm	3 phases	62	2,2	21	1 speed	7	
	TC511M	1Bm	3 phases	42	1,1	11	1 speed	7	
	TL511M	1Bm	3 phases	62	1,1	11	1 speed	7	
	TC504M	1Bm	3 phases	42	0,75	4	1 speed	7	
	TL504M	1Bm	3 phases	62	0,75	4	1 speed	7	
	TC511MM	1Bm	1 phase	42	1,1	11	1 speed	7	
	TL511MM	1Bm	1 phase	62	1,1	11	1 speed	7	
	TC521VM	1Bm	1 phase	42	2,2VV	21	Variation	7	
	TL521VM	1Bm	1 phase	62	2,2VV	21	Variation	7	
	TC521VT	1Bm	3 phases	42	2,2VV	21	Variation	7	
	TL521VT	1Bm	3 phases	62	2,2VV	21	Variation	7	
	TC511VM	1Bm	1 phase	42	1,1VV	11	Variation	7	
	TL511VM	1Bm	1 phase	62	1,1VV	11	Variation	7	
	TC511VT	1Bm	3 phases	42	1,1VV	11	Variation	7	
	TL511VT	1Bm	3 phases	42	1,1VV	11	Variation	7	
	TC511B	1Bm	3 phases	42	0,37/1,1	3/11	2 speed	7	
	TL511B	1Bm	3 phases	42	0,37/1,1	3/11	2 speed	7	
	800	TC813M	1Bm	3 phases	59	3	13	1 speed	8
		TL813M	1Bm	3 phases	88	3	13	1 speed	8
TC810M		1Bm	3 phases	59	2,2	10	1 speed	8	
TL810M		1Bm	3 phases	88	2,2	10	1 speed	8	
TC805MM		1Bm	1 phase	59	1,1M	5	1 speed	8	
TL805MM		1Bm	1 phase	88	1,1M	5	1 speed	8	
TC805M		1Bm	3 phases	59	1,1	5	1 speed	8	
TL805M		1Bm	3 phases	88	1,1	5	1 speed	8	
TC813V		1Bm	3 phases	59	3VV	13	Variation	8	
TL813V		1Bm	3 phases	88	3VV	13	Variation	8	
TC810VM		1Bm	1 phase	59	2,2VV	10	Variation	8	
TL810VM		1Bm	1 phase	88	2,2VV	10	Variation	8	
TC810VT		1Bm	3 phases	59	2,2VV	10	Variation	8	
TL810VT		1Bm	3 phases	88	2,2VV	10	Variation	8	
TC810B		1Bm	3 phases	59	0,75/2,2	3/10	2 speed	8	
TL810B		1Bm	3 phases	88	0,75/2,2	3/10	2 speed	8	
990	TC910M	1Bm	3 phases	34	2,2	10	1 speed	9	
	TL910M	1Bm	3 phases	50	2,2	10	1 speed	9	
	TC905MM	1Bm	1 phase	34	1,1M	5	1 speed	9	
	TL905MM	1Bm	1 phase	79	1,1M	5	1 speed	9	
	TC905M	1Bm	3 phases	34	1,1	5	1 speed	9	
	TL905M	1Bm	3 phases	79	1,1	5	1 speed	9	
	TC913M	1Bm	3 phases	15	3	13	1 speed	9	
	TL913M	1Bm	3 phases	22	3	13	1 speed	9	
	TC910VM	1Bm	1 phase	34	2,2VV	10	Variation	9	
	TL910VM	1Bm	1 phase	50	2,2VV	10	Variation	9	
	TC910VT	1Bm	3 phases	34	2,2VV	10	Variation	9	
	TL910VT	1Bm	3 phases	50	2,2VV	10	Variation	9	
TC910B	1Bm	3 phases	34	0,75/2,2	3/10	2 speed	9		
TL910B	1Bm	3 phases	50	0,75/2,2	3/10	2 speed	9		
1500	TC1504M	1Bm	3 phases	11	1,5	4	1 speed	11,5	
	TL1504M	1Bm	3 phases	16	1,5	4	1 speed	11,5	
	TC1509M	1Cm	3 phases	11	3	9	1 speed	11,5	
	TL1509M	1Cm	3 phases	16	3	9	1 speed	11,5	

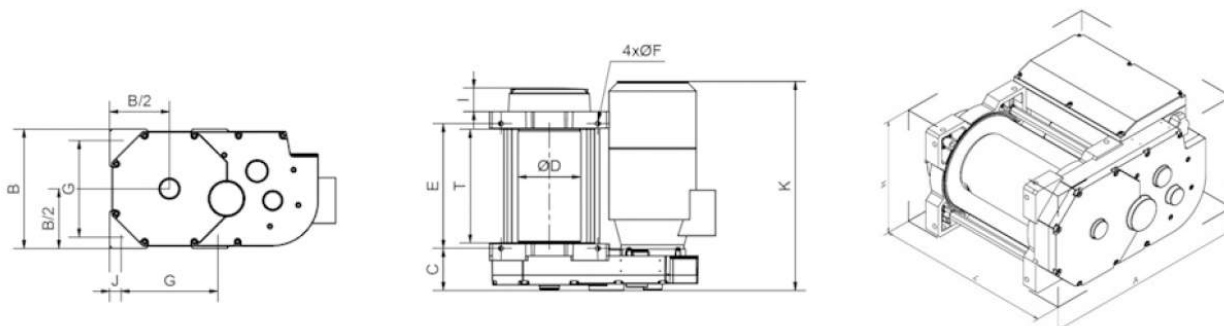
**6.4 Dimensions and fastenings**

**TIRLIFT 2 Low Voltage version**

Models	TIRLIFT 2 250-500		TIRLIFT 2 600-1500	
	Standard	Long	Standard	Long
A mm	According to motors, see table.			
B mm	243	243	304	304
C mm	79	79	107,5	107,5
Ø D mm	121	121	159	159
E mm	255	255	318	463
Ø F mm	10,5	10,5	12,5	12,5
G mm	197	197	246	246
H mm	According to motors, see table.			
I mm	68	68	62	62
J mm	23	23	29	29
K mm	488	471	495,5	495,5
L mm	According to motors, see table.			
M mm	121,5	121,5	152	152
N mm	121,5	121,5	152	152
T mm	230	345	290	435

	TIRLIFT 2 250-500					
	Standard			Long		
Motor kW	A mm	L (without/with limit switch) mm	H mm	A mm	L (without/with limit switch) mm	H mm
0,75	451	356/421	284,5	451	468/533	284,5
1,1	462	356/421	284,5	462	468/533	284,5
2,2	473	488/488	306,5	473	468/533	306,5

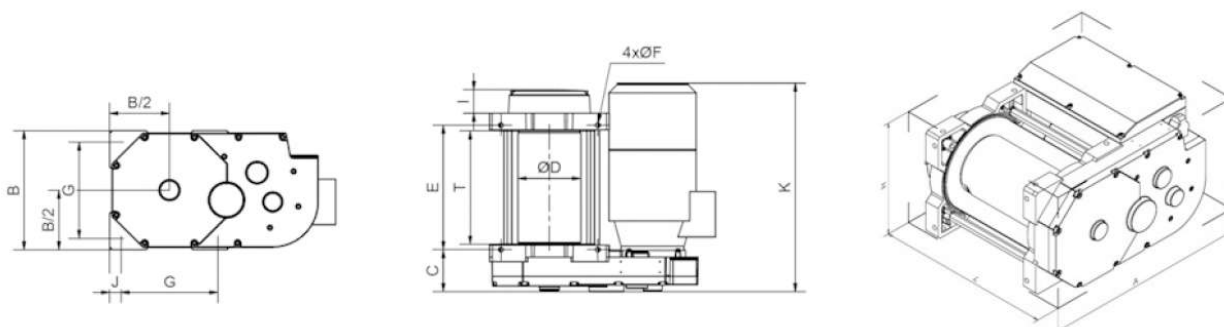
	TIRLIFT 2 600-1500					
	Standard			Long		
Motor kW	A mm	L (without/with limit switch) mm	H mm	A mm	L (without/with limit switch) mm	H mm
0,75	535,5	456/516	332,5	535,5	601/661	332,5
1,1	543	456/516	332,5	543	601/661	332,5
1,5	541	456/516	332,5	541	601/661	332,5
2,2	554	507/516	332,5	554	601/661	332,5
3	558	511/516	332,5	558	601/661	332,5
4	558	533/533	332,5	558	601/661	332,5

**TIRLIFT 2 speed variation version**

Models	TIRLIFT 2 250-500		TIRLIFT 2 600-1500	
	Standard	Long	Standard	Long
A mm	According to motors, see table.			
B mm	243	243	304	304
C mm	79	79	107,5	107,5
Ø D mm	121	121	159	159
E mm	255	370	318	463
Ø F mm	10,5	10,5	12,5	12,5
G mm	197	197	246	246
H mm	According to motors, see table.			
I mm	68	68	62	62
J mm	23	23	29	29
K mm	488	471	495,5	495,5
L mm	According to motors, see table.			
M mm	121,5	121,5	152	152
N mm	121,5	121,5	152	152
T mm	230	345	290	435

	TIRLIFT 2 250-500					
	Standard			Long		
	A mm	L (without/with limit switch) mm	H mm	A mm	L (without/with limit switch) mm	H mm
Motor kW	475	356/421	345	475	468/533	345
0,75	475	356/421	345	475	468/533	345
1,1	475	488/488	345	475	468/533	345
2,2	477	488/488	345	475	468/533	345
3						

	TIRLIFT 2 600-1500					
	Standard			Long		
	A mm	L (without/with limit switch) mm	H mm	A mm	L (without/with limit switch) mm	H mm
Motor kW	574	456/516	391	574	601/661	391
0,75	574	456/516	391	574	601/661	391
1,1	574	456/516	391	574	601/661	391
1,5	574	495,5/516	391	574	601/661	391
2,2	574	511/516	391	574	601/661	391
3	574	533/533	449	574	601/661	449
4						



**6.5 Accessories**

TIRLIFT 2 winches can be delivered with ropes and accessories.

**6.6 FEM classification**

There are eight groups of mechanisms:

FEM	1 Dm	1 Cm	1 Bm	1 Am	2m	3m	4m	5m
ISO	M 1	M 2	M 3	M 4	M 5	M 6	M 7	M 8

To define the group for a lifting machine, winch or hoist, three essential parameters must be considered:

**a- The maximum load to be lifted**

Including the weight of the rope and any lifting accessories present (hook etc.), except if they have a total weight less than or equal to 5% of the load to be lifted.

**b- The duty factor**

Indicates the extent to which the lifting machine is used at maximum load or with a reduced load. There are four different duty factors:

Light	Lifting machines rarely subject to maximum load and regularly used for very light loads.	$k \leq 0.5$
Medium	Lifting machines quite often subject to maximum load and regularly used for light loads.	$0.5 < k \leq 0.63$
Heavy	Lifting machines often subject to maximum load and regularly used for medium loads.	$0.63 < k \leq 0.8$
Very heavy	Lifting machines regularly subject to loads close to the maximum load.	$0.8 < k \leq 1$

For an exact classification, it is preferable to calculate the average cubic value using the following formula:

$$k = \sqrt[3]{(\beta_1 + \gamma)^3 \cdot t_1 + (\beta_2 + \gamma)^3 \cdot t_2 + \dots + \gamma^3 \cdot t_\Delta}$$

where:

$\beta$ = <u>payload or partial load</u> rated capacity	$t$ = <u>operating time with payload or partial load + dead load</u> total operating time
$\gamma$ = <u>dead load</u> maximum capacity	$t_\Delta$ = <u>operating time with dead load only</u> total operating time



**c- Operating class**

This is the operating time per day, on the basis of 250 working days per year.

The lifting machine is considered to be in operation when it is moving; however, it is not considered to be in operation during downtimes, for example, between lifting and lowering.

**These three parameters give the FEM classification for the TIRLIFT 2 :**

TIRLIFT 2			
Usage rate	Average operating time per day in hours.		
	30'	1 h	2 h
Light	1 Dm	1 Cm	1 Bm
Medium	1 Cm	1 Bm	1 Am
Heavy	1 Bm	1 Am	2m
Very heavy	1 Am	2m	3m

**6.7. Variable speed drive**

**6.7.1. General**

**WARNING**

- The electronic speed control equipment of the electric motors are connected to potentially dangerous voltages. When connecting, performing servicing or dismantling these appliances, the greatest of precautions must be taken to prevent electric discharges.
- This appliance contains capacitors which accumulate energy. When the appliance is switched off, these capacitors retain a dangerous voltage for a few minutes subsequent to switching off. Wait at least 5 minutes before opening or touching live parts of the appliance.
- The earth connection of the appliance must be connected to a suitable earth connector of the electrical installation.
- This appliance must be installed, adjusted and serviced by a qualified electrician. This person must be familiar with the construction and commissioning of this appliance.
- The variable speed controls fitted with a CEM filter and faradised motor rope may have significant leakage currents to the earth, especially when the appliance is switched on. Differential switches could therefore be tripped accidentally. Furthermore, the diode rectifying bridge in the input circuit could generate a direct current in the phases of the network. You are advised to use differential switches which are not sensitive to these transient currents and of a high tripping level. The other equipment must be protected by one or more separate differential switches.
- A differential switch upstream to a variable speed control is not adequate protection.

**6.7.2. Wiring**

**DANGER**

- Make sure that the appliance is connected to a sound earth.
- The wiring must be performed by a qualified electrician adhering to the safety standards of the country of installation.

- Do not perform or modify the wiring before you are personally sure that the voltage of the network is no longer present on the appliance and that any residual voltage of the appliance has disappeared.
- Check that the voltage of the network corresponds to the voltage of the variable speed.
- Do not connect the phases of the network to the output terminals for the connection of the motor (U, V, W).
- Tighten the screws to the suitable tightening torque. Check, before switching on, that all the connections are securely tightened.

## 7 - Handling – Storage

**Important:** the angle formed between the hook and the two sling points must not exceed 45°.

- Lift and place the winch carefully without dropping it.
- Do not forget that the centre of gravity of the winch is off-centred.

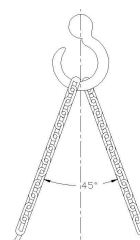

For further information on the weight of the winch, refer to section § 6.2 – Models available.

When stored, these winches must be protected from bad weather in a clean and dry place at a temperature between -10°C and +50°C.

## 8 - Assembly and start-up

### 8.1. Securing the winch:

The flatness deviation between the 4 points of support must not exceed 1mm, in order to avoid undue strain on the device and ensure its longevity.

The support must be able to withstand the loads to which it is subjected. An unsuitable installation site may lead to serious accidents.

To assess the suitability of the place of installation and its resistance to loads, you must take into account any possible overloading, the weight of the winch itself and the weight of the options and/or accessories fitted to it, including all dynamic forces. The winch user is responsible for determining the place of installation. If in doubt with regard to the suitability of a place of installation, contact a civil engineer or a statics specialist.

Calculate and check that the attachment support has a resistance that exceeds the loads to be lifted or pulled.

The fixation must be performed using 4 screws of 10 mm diameter and 8.8 class (for TIRLIFT 2 250 to 500 kg) and 12 mm diameter and 8.8 class (for TIRLIFT 2 600/800/990/1500 kg).

In all cases where this is possible, favor an assembly using special nuts supplied with the winch & shown below.

Their contour adapted to the Foundry device allow a distribution of the efforts and avoid their rotation especially during the tightening process.

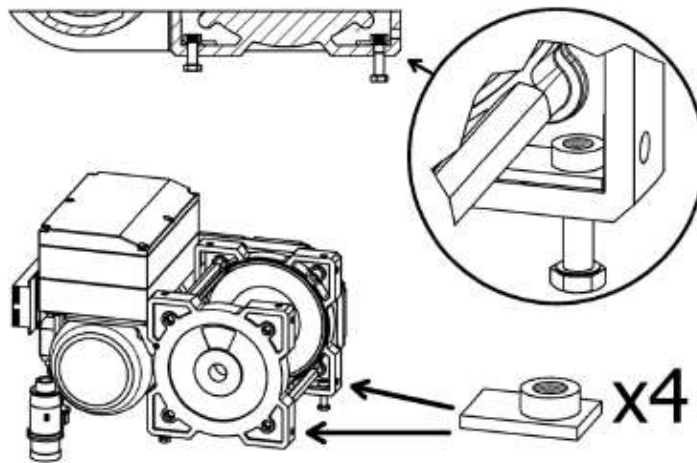

**8.2. Wire rope exits**

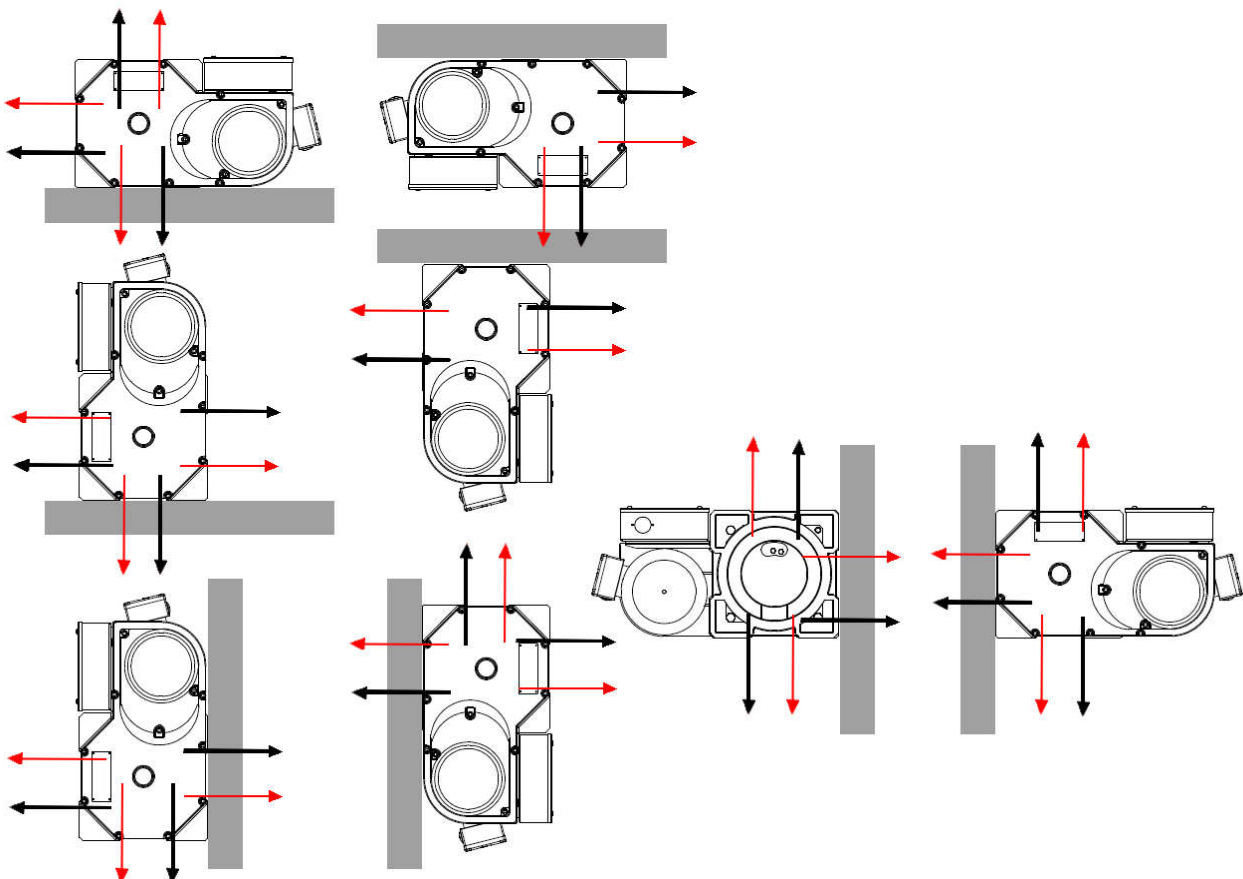

**Key:**                    **Standard exit, right-hand laid wire rope**  
Non-standard exits, left-hand laid wire rope

**IMPORTANT!**

- . Use of the standard rope clamp on the limit switch side.
- . A non-standard output can be made into a standard one by using the second rope clamp, as long as this is known when placing the order.

### 8.3. Change to initial assembly

(for reference numbers, refer to the exploded view in the appendix).

- Remove the screws ②<sup>1</sup>.
- Disconnect the flange ②<sup>0</sup> using a mallet.
- Remove the perforated sheeting ①<sup>9</sup>.
- Identify the tie fastening ①<sup>8</sup>.
- Loosen the tie ①<sup>8</sup> before changing place.
- Screw in its new position tightening carefully.
- Position the sheeting ①<sup>9</sup> in its new position.
- Fit on its bearing by tightening the screws ②<sup>1</sup> and checking that the sheeting is correctly positioned ①<sup>9</sup> in the grooves.

### 8.4. Set-up

The service life of a winch depends on its correct installation and set-up.

It is essential that you read this manual carefully before installing, using and servicing your machine.

Any use which contravenes our instructions may create hazards. In this case, the manufacturer cannot accept any liability.

Do not use this machine before having read and understood the instruction manual in its entirety

Always keep the manual close to the machine, available to the operator and the maintenance staff

Comply and ensure compliance with the safety rules.

- Connect to the power supply (see section § 8.5 - Electrical connections).
- Check the rope and hook.
- Ensure you are ready to press the emergency stop button at all times, with no load attached, then check that the movement of the hook corresponds to the direction of the arrows indicated on the control unit.
- Check that the brake works: with a nominal load attached, lift the load and lower it again or, in the case of pulling, pull this load.
- Check that the limit switch works.
- The winch has been subjected to dynamic and static tests in the factory (cf. Test record).

To ensure correct winding of the rope, the distance between the deflecting pulley and the drum must equal to or be greater than 20 times the length of the drum.

**Deflection angle**

**Smooth drum**

**Grooved drum**

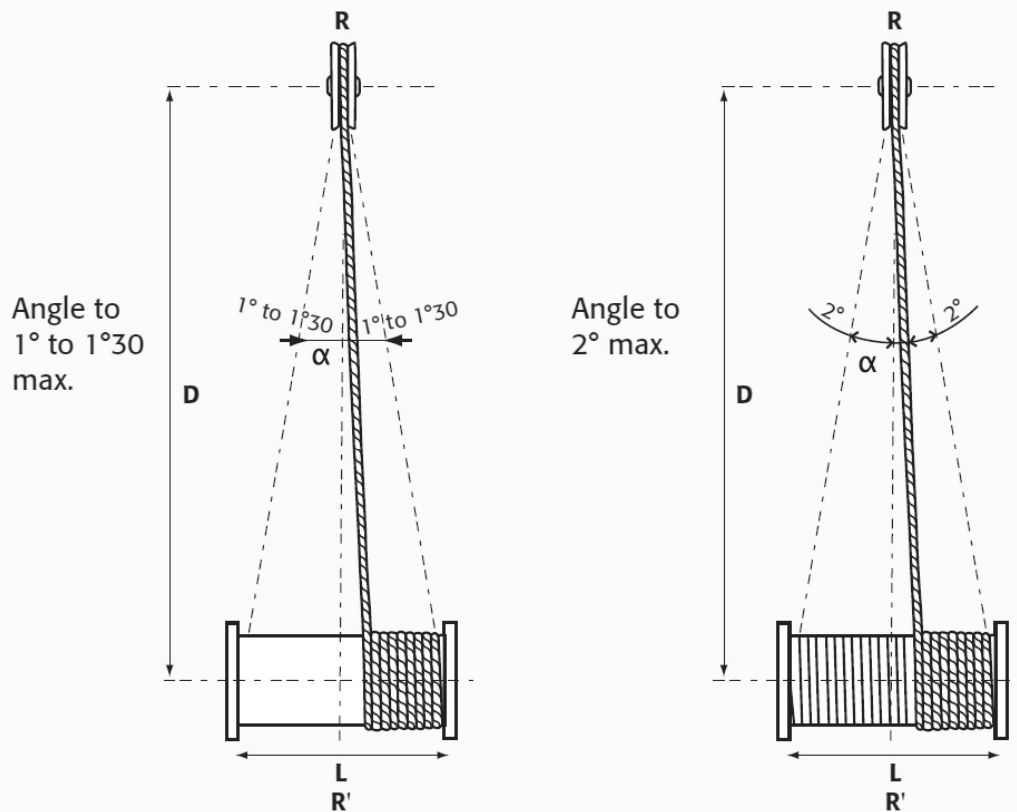

$\alpha = 1.5^\circ$  max. on smooth drum

$\alpha = 2^\circ$  max. on grooved drum

In practice, observe a distance **D minimum** of 20 times L.

## 8.5 Electrical connections

### 8.5.1. Mains supply

- Check that the network voltage corresponds to the one required for the machine.
- Measure the real value of this voltage. There should be no more than a 5% difference between it and the nominal value.
- The machine should be connected to an electrical line with the correct protection devices: fuse/protective circuit breaker, main circuit breaker.

**Very important:** the winch will only provide full power if the motor is supplied via a cable section which is suited to this use.

Recommended power cable section:

VOLTAGE	TYPE	Section of power cable		Power
		Length 10 m	Length 30 m	
220 V mono.	2 + T	2,5 mm <sup>2</sup>	4,0 mm <sup>2</sup>	0,75/1,1 kW
230 V tri.	3 + T	1,5 mm <sup>2</sup>	2,5 mm <sup>2</sup>	0,75/1,1 kW
	3 + T	2,5 mm <sup>2</sup>	4,0 mm <sup>2</sup>	2,2/3 kW
	3 + T	2,5 mm <sup>2</sup>	6,0 mm <sup>2</sup>	5,5 kW
400 V tri.	3 + T	1,5 mm <sup>2</sup>	1,5 mm <sup>2</sup>	0,75/1,1 kW
	3 + T	1,5 mm <sup>2</sup>	2,5 mm <sup>2</sup>	2,2/3 kW
	3 + T	2,5 mm <sup>2</sup>	4,0 mm <sup>2</sup>	5,5 kW

- Power supply via a generator is possible: minimum power in kVA equal to or greater than five times the motor power in kW.

### 8.5.2. Connection

**IMPORTANT: ALWAYS ENSURE THE POWER SUPPLY IS SWITCHED OFF BEFORE CONNECTING THE WINCH** (Main circuit breaker on the cut line).

#### ▪ Socket connection

The appliance is systematically supplied with a power cord (length 0.5 m) equipped with a plug for connection to a wall socket or wire socket.

The type of plug depends on the power supply voltage:

- . 2P+G (domestic type) in 230 V single-phase
- . 3P+G in 230 V or 400 V three-phase (in this case the plug socket is also supplied)

#### ▪ Connection in the unit

**IMPORTANT:** this type of electrical connection of the winch must be performed by a competent and qualified person.

Disconnect the power cord inside the electrical unit by accurately identifying the location of the terminals.

Pass the new cable into the unit's compression gland and reconnect it in the same way as the power cord.

A circuit breaker must be placed at a maximum of 10 m from the place of use.

After connecting the machine, check that it functions correctly.

**IMPORTANT:** In three-phase power supply, check in particular that the direction of rotation is correct.

In fact, in three-phase, the drum's direction of rotation depends on the allocation of the phases to each of the three power supply connection terminals. To reverse the direction of rotation, simply switch the two phases: under no circumstances change the direction labels in the control unit or the cabling inside the winch.

- Never "shunt" the disconnecting switches, electrical switches, prevention or limitation equipment.
- Never block, adjust or remove switches or end stops in order to go beyond the levels that they allow.

### 8.5.3. Securing the working rope

Important: in three-phase the drum's direction of rotation differs depending on the power supply connection. Switching the two phases changes the drum's direction of rotation.

Reminder: check the maximum capacity of the winch.

#### **Very important:**

The safety regulations require that two to three whorls of rope always stay on the drum.

To comply with the legislation, the rope diameter must not exceed the recommended diameter.

If the rope and the hook used were not supplied with the machine by the manufacturer, check that they guarantee a level of safety corresponding to table § 6.6.

**IMPORTANT:** even if the rope was supplied wound on to the winch, it was not tensioned during assembly. The user must tension it using a minimum force of 1% of its breaking load.

The service life of the steel ropes used on the winch depends on a number of factors, including the type of the work cycles (lifting height, lifting speed, number and type of deviations, etc.) and the operating mode (number of layers, distribution of the work cycles over the length of the steel rope, etc.). The service life of steel ropes is therefore subject to considerable variation depending on these factors.

Remember that rope must be replaced with equipment which meets the same specifications as the original rope.

This replacement must be recorded in the maintenance booklet.

#### **Measuring the rope diameter using sleeve callipers:**

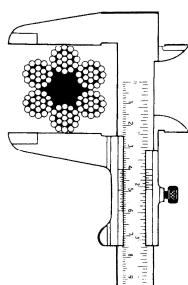

**Correct measurement**

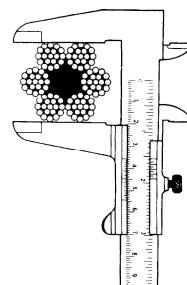

**Incorrect measurement**

### Handling steel ropes

- Always use suitable protective gloves when handling steel ropes.
- Never use a rope with faults such as:
  - ✓ an unacceptable number of broken strands.
  - ✓ basket distortions.
  - ✓ broken bird-caging.
  - ✓ flattening.
  - ✓ constrictions.
  - ✓ strand extrusions.
  - ✓ broken rope cores.
  - ✓ slack strands.
  - ✓ bends or loops.
- Always check the level of wear of the rope before use.
- Never use steel ropes as loops.
- Never expose steel ropes to angular or sharp edges.



### Unwinding the rope from its reel:

#### CORRECT:

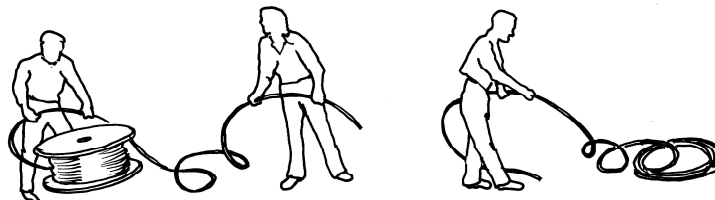
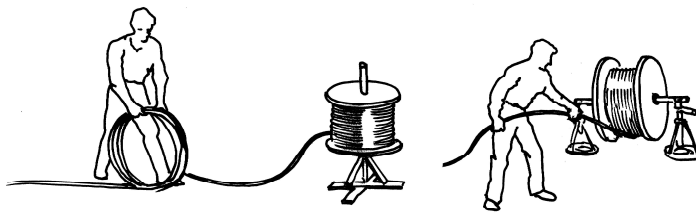

#### INCORRECT



## Fastening the rope

### On the first rope clamp



### On the second rope clamp



Identify using the photos above.

- If necessary, remove the limit switch.
- Loosen the screws.
- Insert the end of the rope between the drum flange and the cable clamp.
- Tighten the screws.
- Check that the rope is securely clamped.
- Reassemble the limit switch.

The rope should never form a loop.

Important: the direction of rotation of the drum depends on how the machine is connected.

## Winding the rope on the drum:

**Reminder:** the maximum capacity of these winches varies on each model (see section §6.3).

**Very important:** The safety regulations require that 3 whorls of rope always stay on the drum. To comply with the legislation, the rope diameter must not exceed 7 mm for the TIRLIFT 2 250/350/500 or 12 mm for TIRLIFT 2 600/800/990/1500. If the rope and the hook used were not supplied with the machine by the manufacturer, check that they guarantee a level of safety corresponding to coefficient 5.

**Winding the rope on the drum:** to do this, tension the rope and wind it with joined strands onto the drum. Check the direction of rope winding according to the three-phase connection.

Start to wind the rope forming a spiral to the right.

The first layer must be wound in a compact manner and under tension. Take a mallet or a block of wood and knock the turns against one another; not too hard to prevent the strands from overlapping one another, but tightly enough to prevent the rope from moving on the drum. If the first layer is wound too loose, the next layer will form a space in the first layer that will result in an open area. If the first layer is too tight, the subsequent layers will not have enough space between turns.

In any case, the first layer and all the other layers must be wound onto the drum with enough pre-tension (5-10 % of the MWL of the rope). If the rope is wound without any tension, it will suffer from crushing and premature flattening caused by the loaded upper layers.

Even if the first layer is wound correctly during installation, it will expand a little while in service. When the first layer expands (loss of pre-tension) the initial procedure **MUST** be performed at regular intervals.

Otherwise, the "hard" turns will severely crush the base layers.

Whatever you do, **DO NOT** pass the rope through a clamping mechanism. For example, two blocks of wood screwed together. **THIS WILL CAUSE IRREPARABLE DAMAGE TO THE ROPE!**

**It is important** to respect the indication below; if the rope start on the winch is at the bottom, respect the same principle. Failure to respect this precaution will damage your rope irretrievably and it will become extremely dangerous.

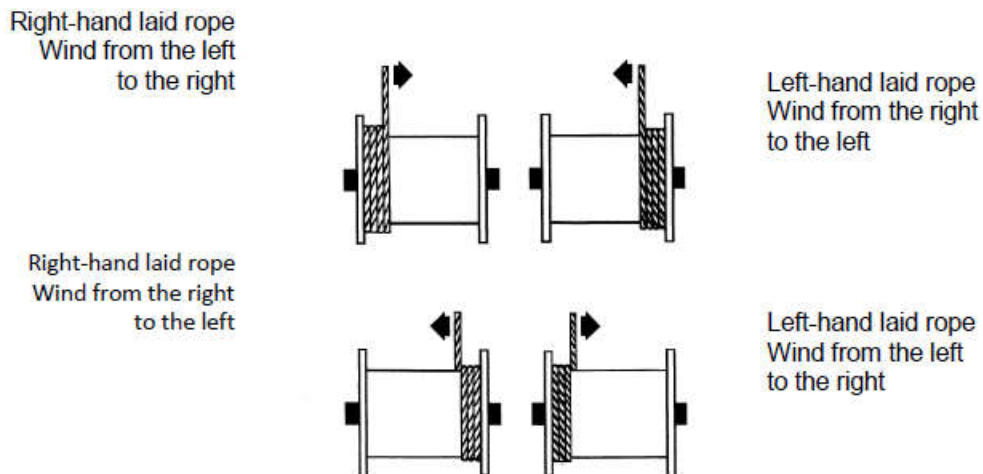

It is important to respect the "natural" winding direction of the rope (the direction of manufacture and storage) otherwise it risks of considerably reducing its service life.

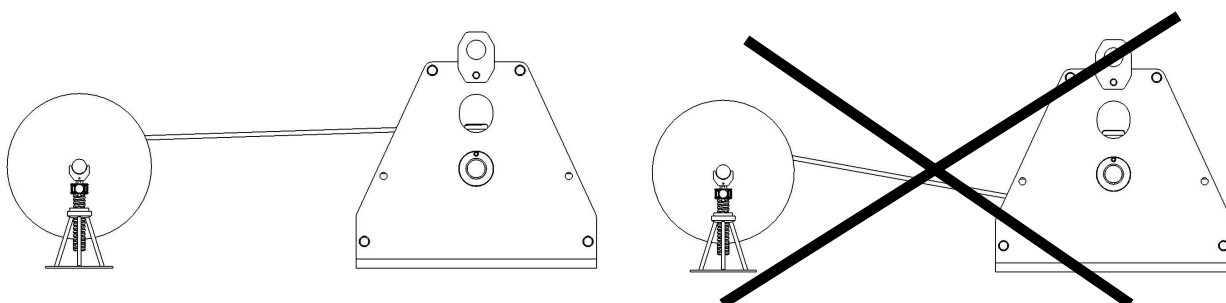

Check the direction of rope winding according to the motor connection.

Principle of reeving:

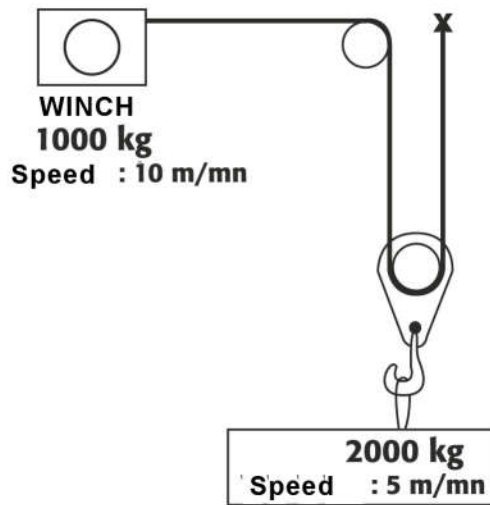

### 8.5.4. Adjusting the limit switch

A. Clock type

Remove the protective cover of the device (inside this cover you will find the diagram below). The levers, which are now accessible, can be turned manually.

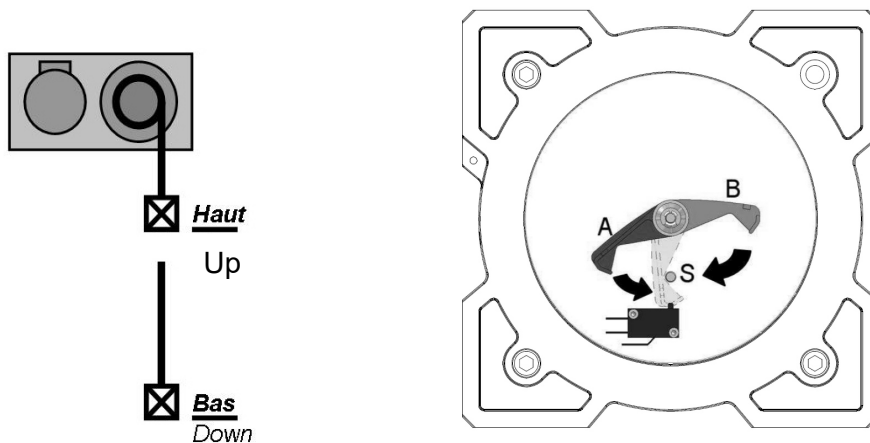

**Adjustment of the winding stop point (top limit switch):**

Wind the rope to the maximum desired winding point. Stop the winch.

Still in this position, manually move the red lever (2) to the lowest position of the rotation circle, where it activates the switch (3)

**Adjustment of the unwinding stop point (bottom limit switch):**

Unwind the rope to the maximum desired unwinding point. Stop the winch.

Still in this position, manually move the black lever (1) to the lowest position of the rotation circle, where it activates the switch (3)

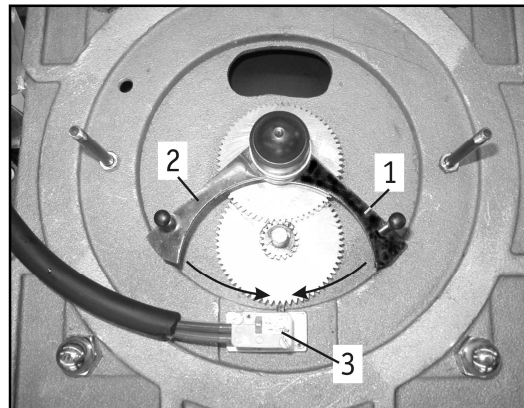

B. Rotating cam limit switch IP66-67

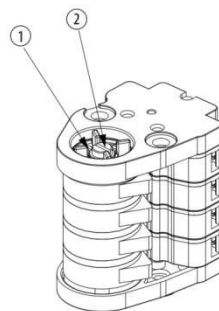

Before doing anything, turn off the main power supply to the winch.

To set the cams properly, loosen the central screw ② of the group of cams. Then set the trigger point for each cam using their adjustment screws ①. The screws are numbered to indicate the cams in increasing order from the bottom of the group to the top. Retighten the central screw.

## 9 - Servicing and maintenance

### 9.1. Winches

Respect the following instructions, in particular if your winch is used in a large number of different locations or in a particularly dirty and damp environment:

- Remove most of the dirt from the winch.
- Always store the winch in a dry, clean place.

**Servicing and maintenance operations on the rope must be carried out without any load on the winch.**

#### 9.1.1. - Before starting up

Check:

- The electrical connections are in good working order.
- The rope is correctly fastened to the drum.
- The exterior appearance of the winch.

#### 9.1.2. - When using for the first time

At the start of the installation process, it is recommended that you respect a running-in period of thirty hours at  $\frac{3}{4}$  of the load. The nominal capacity will be obtained after this running-in period.

#### 9.1.3. - Periodic servicing

See also chapter 5: Obligatory regulatory checks by the user

- Check that the mechanical components are well lubricated during each periodic general inspection.
- Renew the grease every 100 hours or every three years (FUCHS Renolit CX12 grease).

#### **Very important:**

Contact our after-sales service in the event of a change in the type of grease.

### 9.2. Ropes

The wire ropes must be cleaned and greased regularly using a special grease which penetrates in the rope core.

Only use appropriate and harmless cleaning products for all the components of the rope, including the core.

If lubrication is impossible for usage-related reasons, the service life of the rope will be reduced considerably and increased monitoring of the rope will therefore be necessary.

The ropes must be checked visually every day.

**Servicing and maintenance operations on the rope must be carried out without any load on the winch.**

### 9.3. Hooks

- Check the hook and its safety latch
- If the rope and hook are not supplied by the manufacturer, check that the parts used guarantee a level of safety corresponding to table in section §6.6.
- Check the fastening points of the reeving on a regular basis.



### 9.4. Brake

- In the low voltage control and speed variator version:  
Regularly dust the brake and adjust the air gap if it exceeds 0.3 mm.  
To do this, use a 0.2 mm thick shim and adjust screws and ① nuts ②.

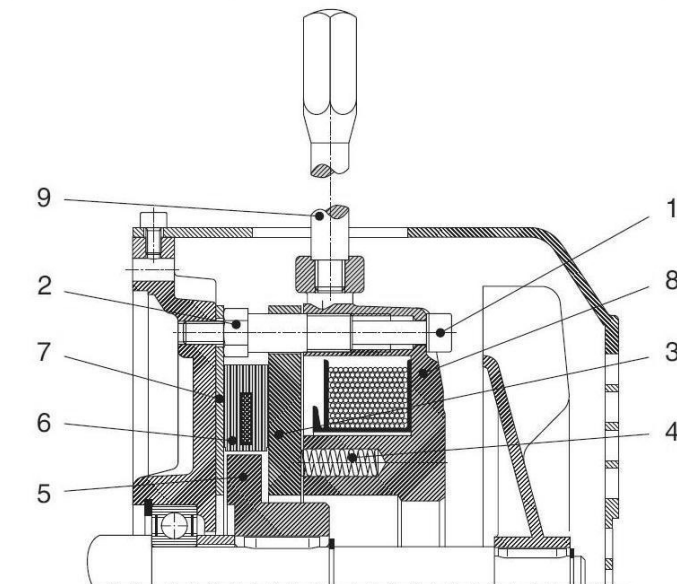
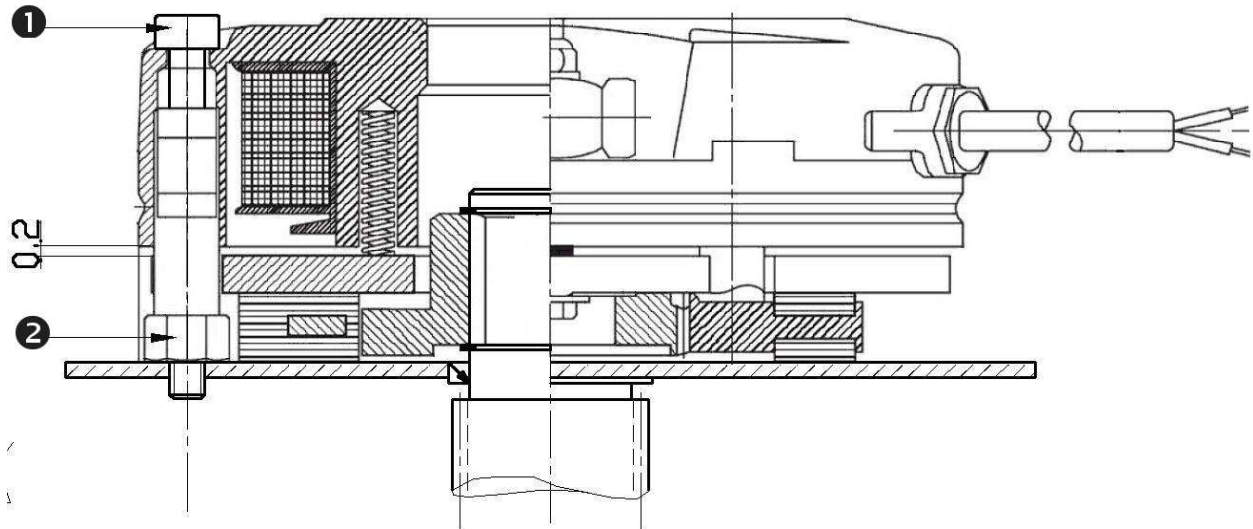

Key:

- 1 Cheese head screw
- 2 Adjusting nut
- 3 Frame
- 4 Pressure springs
- 5 Hub
- 6 Friction lining
- 7 Friction pad
- 8 Induction material
- 9 Manual release (optional)

. Operating principle:

On starting the motor, the internal magnetic field opens the brake by lifting the conical plate from the friction surface at the bottom of the motor.

On stopping the motor, the magnetic field disappears. The central spring closes the brake again by bringing the conical panel back into contact with the motor's rear flange.

. Adjusting the braking torque

Remove the cap ⑤ on the fan cover.

Gradually turn the self-locking nut ⑥:

- . clockwise to reduce the braking torque
- . anti-clockwise to increase the torque

. Adjusting the air gap

The air gap ⑦ must be adjusted in the event of excessive wear of the friction lining (min. 0.6 mm/max. 0.8 mm).

Remove the cover ① and the fan ②.

Loosen the three screws by a few turns ③.

Turn the ring nut ④ anti-clockwise ( $30^\circ \approx 0.12 \text{ mm}$ ) to reduce the air gap ⑦.

Tighten the three screws ③.

Reposition the fan and its cover.

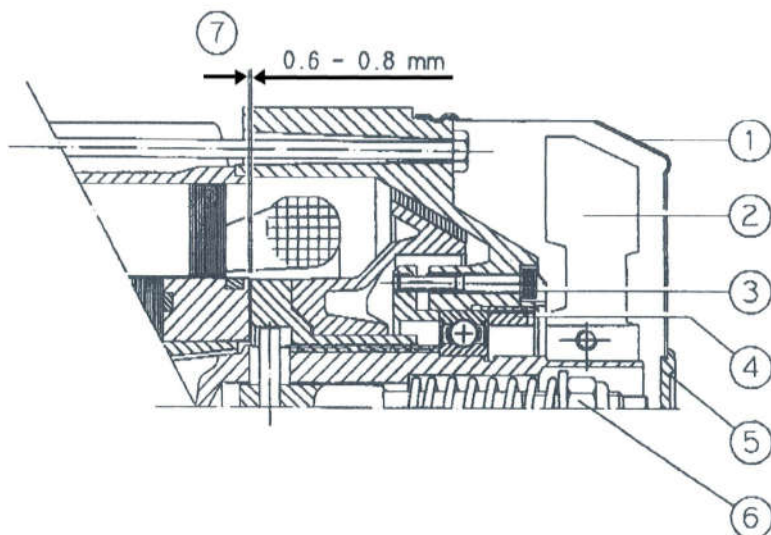

**Key:**

- ① Cover
- ② Fan
- ③ Screw
- ④ Ring nut
- ⑤ Cap
- ⑥ Self-locking nut
- ⑦ Air gap

## 10 - Taking out of use

If the equipment is in a state of disrepair likely to give rise to risks, it must not be used and must be taken out of service:

- disassemble the electrical control components
- for disposal of the equipment, it should be sent to the corresponding collection centre. Make sure to remove the grease before disposing of the equipment.

## **11 - Spare parts**

If during maintenance operations you notice that certain parts of your winch need to be replaced, use VERLINDE original parts only.

For all spare parts orders, please indicate the following specifications on your order

- ✓ The type and capacity of the winch (indicated on the nameplate).
- ✓ The serial number and year of manufacture (indicated on the nameplate).
- ✓ The designation of the desired parts (exploded views).



## 12 - Operating faults

If you have followed the instructions for assembly and use, any incidents that do occur should be minor.

The following instructions will help you resolve any faults quickly.

<b>Fault</b>	<b>Possible cause</b>	<b>Solution</b>
The motor does not start.	Power supply cut.	Check and correct the problem. Check the emergency stop.
	Brake not released	See "brake fault".
	The contactor does not respond, control fault.	Check the contactor control and eliminate the fault.
	Limit switch engaged.	Check the limit switch.
The motor does not start or starts with difficulty.	The voltage or frequency varies considerably compared to the setting when starting.	Improve the mains conditions. Check the cable sections.
The motor revs and absorbs a lot of current.	The brake is not released.	See "brake fault"
	Faulty winding.	Take the motor to an approved workshop for repair.
	One supply phase missing.	Check the power supply.
The circuit breaker is activated instantly.	Short circuit in the power supply cables.	Eliminate the short circuit.
	Short circuit in the motor.	Have the fault corrected in an approved workshop.
	Power supply cables incorrectly connected.	Correct the connection.
	Motor earth fault.	Have the fault corrected in an approved workshop.
Speed greatly reduced when loaded.	Voltage drop.	Increase the power supply cable section.
Motor too hot (temperature measure)	Insufficient ventilation.	Clear the ventilation lanes.
	Ambient temperature too high.	Respect the authorised temperature range.
	Bad contact in the power supply cable (operates temporarily on 2 phases)	Eliminate the bad contact.
	Circuit breaker activated.	Bad contact in the relays.
	Service factor exceeded (S1 to S10, DIN 57530), e.g. because start speed is too high.	Adapt the service factor to the prescribed conditions; if necessary, call a specialist to determine the type of motor.
Drive system too noisy	Rotating parts vibrate.	Check the balances, eliminate the cause of the vibrations.
	Foreign bodies in the ventilation lanes.	Clean the ventilation lanes.
Brake not released	Max. air gap exceeded due to worn lagging.	Measure and if necessary adjust the air gap.
The motor does not brake.	Incorrect air gap.	Measure and if necessary adjust the air gap.
	Brake lagging totally worn.	Replace the entire lagging retainer.

## **13 - Tests**

This winch has been tested in the factory:

- in a dynamic situation, with a coefficient of 1.1
- in a static situation, with coefficient 1.25

## **14 - Declaration of EC conformity**



**DECLARATION OF CONFORMITY**

F03.48.1 -UK Electric winches

We hereby declare, under our sole responsibility, that the design and manufacture of the machinery referred to below comply with the following essential requirements of harmonization laws of the European Union:

- Directive 2006/42/EC on Machinery
- Directive CEM 2014/30/UE
- Directive BT 2014/35/UE
- Directive RED 2014/53/UE.

The machinery's technical file has been put together by the signatory of this declaration.

This declaration shall become null and void in the event it is changed or if any item is added without our prior consent.

Moreover, this declaration shall become null and void if the machinery is not used in accordance with its instructions for use and if it is not inspected regularly.

**Type of device:** Electric winch

**Model:**

**Force:**

**Serial n°:**

**Funcion:**  Hoisting or hauling equipment  
 Hauling only

**Harmonised standard(s) used, notably:** EN 14492-1

**Quality assurance:** ISO 9001 (certificate registration n°: FQA 9911492)

**Equipment delivered:**  with cable  with hook  
 without cable  without hook  
*Important: these items must comply strictly with the specifications indicated on the manufacturer's plate affixed to the winch and the instructions for use, and they must be supplied by professionals specialised in their use*  
 with limit switch  with load-limiting device  
1000+ kg  
 without limit switch  without load-limiting device  
*For hauling only* *For hauling only*

**and with instructions for use.**

Issued in Vernouillet, on:

**François GURNIKI**  
Managing Director

## 15 - Appendices

- **A** - Diagram of limit switch.....p 33
  - TIRLIFT 2 250, 350 et 500 kg
  - TIRLIFT 2 600, 800, 990 et 1500 kg
- **B** - Electrical diagrams.....p 35

*Important: the following diagrams correspond to a standard installation of our standard models.*

*If the winch is adapted to a specific use, a specific electrical diagram is required: do not hesitate to contact us to obtain this.*

  - TIRLIFT 2 in low voltage control (single-phase/three-phase)
  - TIRLIFT 2 speed variation (single-phase/three-phase)
- **C** - Exploded views and spare parts lists.....p 41
  - TIRLIFT 2 in low voltage control
  - TIRLIFT 2 – Variable speed models
- **D** - Optional equipment.....p 45
  - End limit switches (speed variation and Low Voltage versions)
  - Trouble shooting hand wheel and brake release
  - Second rope clamp
  - Rope slack switch
  - Tubular frame
  - Grooved drum
  - Load limiter
  - Disengaging drum
  - Rocking winch

# A- TIRLIFT 2 LIMIT SWITCH

TIRLIFT 2 250, 350 and 500 kg

Key	Quantity	Designation
1	1	Limit switch central shaft
2	1	TRB 2 limit switch offset shaft
3	1	Grooved surface pin 2 x 12
4	1	TIRLIFT 2 limit switch washer
5	2	Bottom M6 hexagonal nut
6	2	Tie
7	1	Pin stop bush ref. EM 32.180.17.4
8	1	17-tooth black sprocket wheel
9	1	48-tooth black sprocket wheel
10	5	45-tooth grey sprocket wheel
11	5	20-tooth grey sprocket wheel
12	2	TRUARC 5-6 ring
13	1	Limit switch finger support
14	1	Red limit switch finger
15	2	Stop washer
16	1	Green limit switch finger
17	2	Curved washer Ø15x20x2
18	1	Washer M Ø10
19	1	Locked bottom nut M10
20	2	M3 x 30 MF steel spacer stud
21	2	Contactors
22	2	M3x25 CHC screw
23	2	Captive nut
24	2	TRUARC 8-9 ring
25	1	TRB 2 limit switch cover

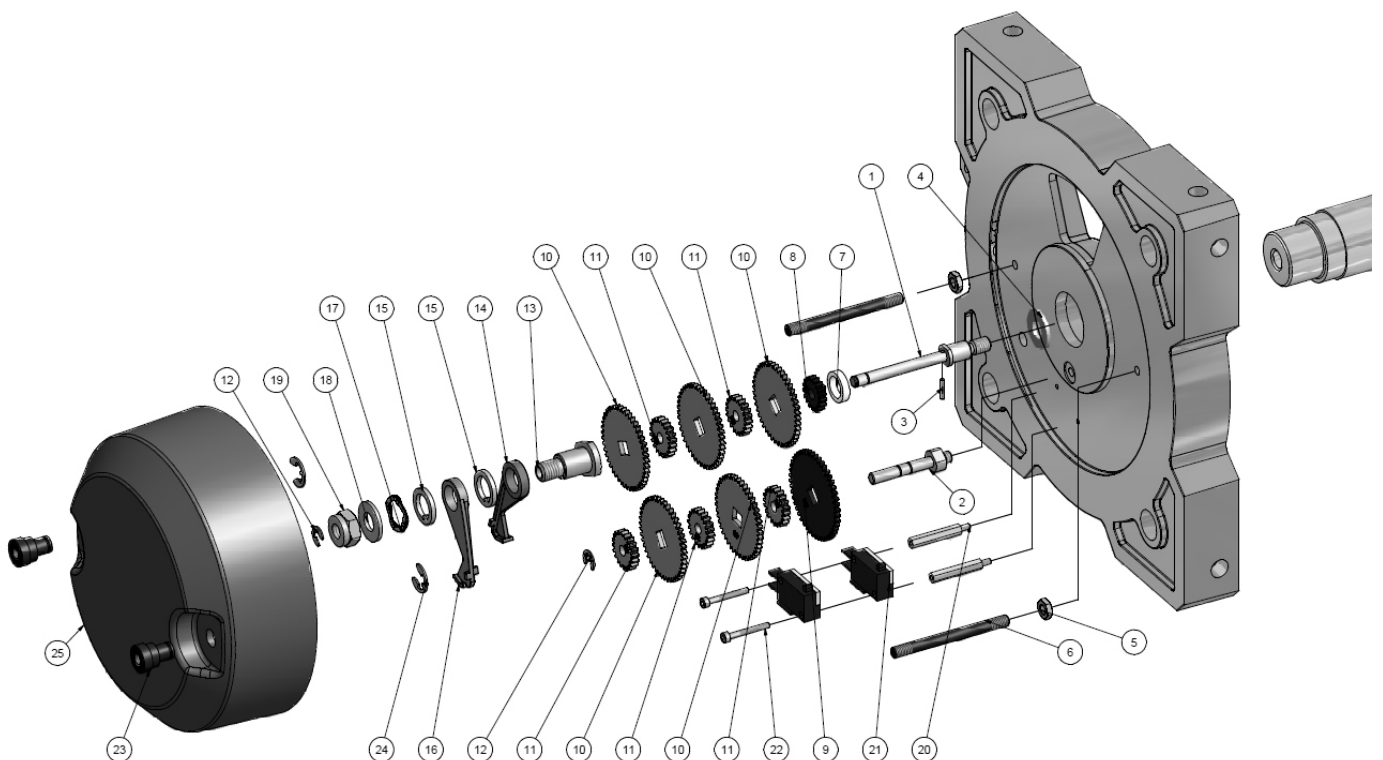

TIRLIFT 2 600, 800, 990 and 1500 kg

Key	Quantity	Designation
1	1	Limit switch shaft
2	1	Limit switch offset shaft
5	2	NF E 24032 M6 nut
6	2	Tie
8	2	M1 17-tooth sprocket wheel
9	2	M1 48-tooth sprocket wheel
10	7	M1 45-tooth sprocket wheel
11	4	m1 20-tooth sprocket wheel
12	2	TRUARC 5-6 ring
13	1	Limit switch finger support
14	1	Red limit switch finger
15	2	Stop washer
16	1	Green limit switch finger
17	2	Curved washer Ø15x20x2
18	1	NF E 25-514 M Ø10 washer
19	1	NF E 25412 M10 locked bottom nut
20	2	M3 x 30 MF steel spacer stud
21	2	Contactactor
22	2	NF E 25-125 M3x25 CHC screw
23	2	Captive nut
24	2	TRUARC Ø8int-Ø9shaft ring
25	1	Cover
26	1	NF E 25-125 M5x16 CHC screw
27	1	Washer
28	1	Drum shaft pin

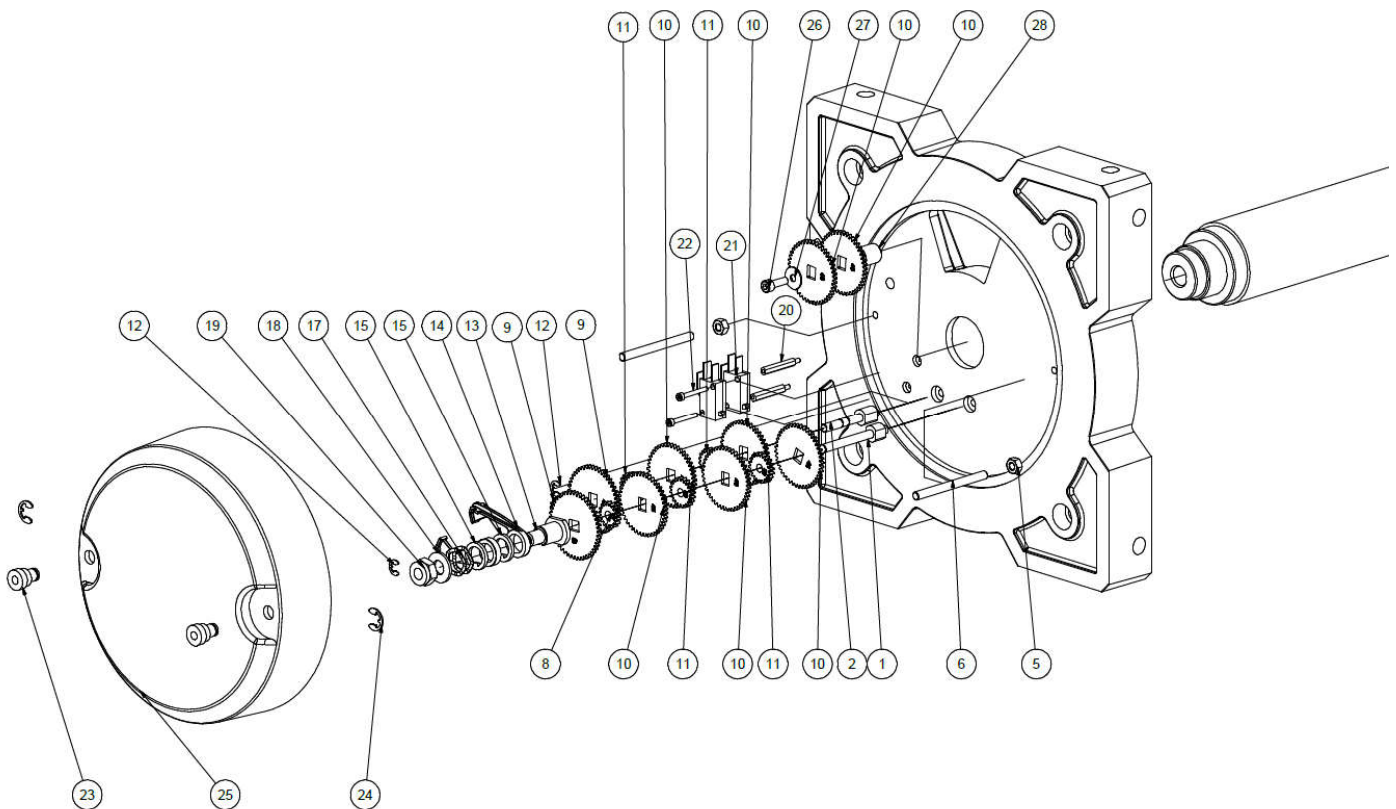



**B - Electrical diagrams**

TIRLIFT 2 low voltage control

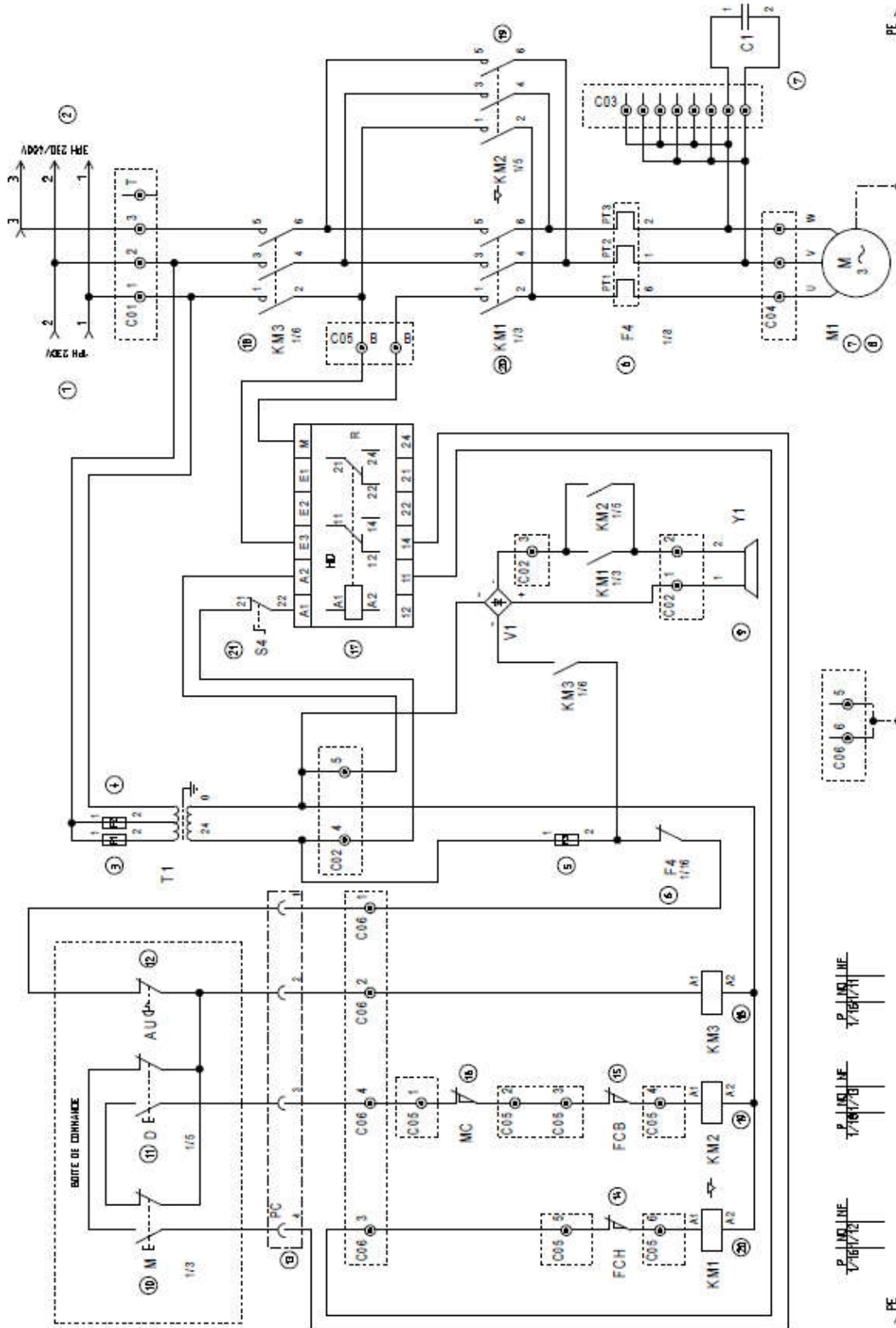

- |          |  |   |   |
|----------|--|---|---|
| 1        | 230 V 50 Hz single-phase power supply      | } | Only one power supply possible  |
| 2        | 230 / 400 V 50 Hz three-phase power supply |   |   |
| 3        | 500 Ma 230/400 V 50 Hz three-phase fuse    | } | Only one fuse position possible according to power supply 1 empty fuse holder mandatory |
| 4        | 500 Ma 500 V 50 Hz single-phase fuse       |   |   |
| 5        | 24 V 1.6 A secondary-circuit fuse          |   |   |
| (Option) | 6 Motor thermal protection                 |   |   |
|          | 7 Single-phase 230 V motor + capacitor     |   |   |
|          | 8 230 / 400 V 50 Hz three-phase motor      |   |   |
|          | 9 24 V DC mechanical brake                 |   |   |
|          | 10 Raising control box                     |   |   |
|          | 11 Lowering control box                    |   |   |
|          | 12 Emergency stop control box              |   |   |
|          | 13 Control unit caravan socket             |   |   |
|          | 14 Upper limit switch                      |   |   |
|          | 15 Lower limit switch                      |   |   |
| (Option) | 16 Rope slack                              |   |   |
| (Option) | 17 CROUZET load limiter                    |   |   |
|          | 18 AU main contactor                       |   |   |
|          | 19 Lowering contactor                      |   |   |
|          | 20 Raising contactor                       |   |   |
| (Option) | 21 (Option) Rearming                       |   |   |



TIRLIFT 2 speed variation 230 V (single-phase)

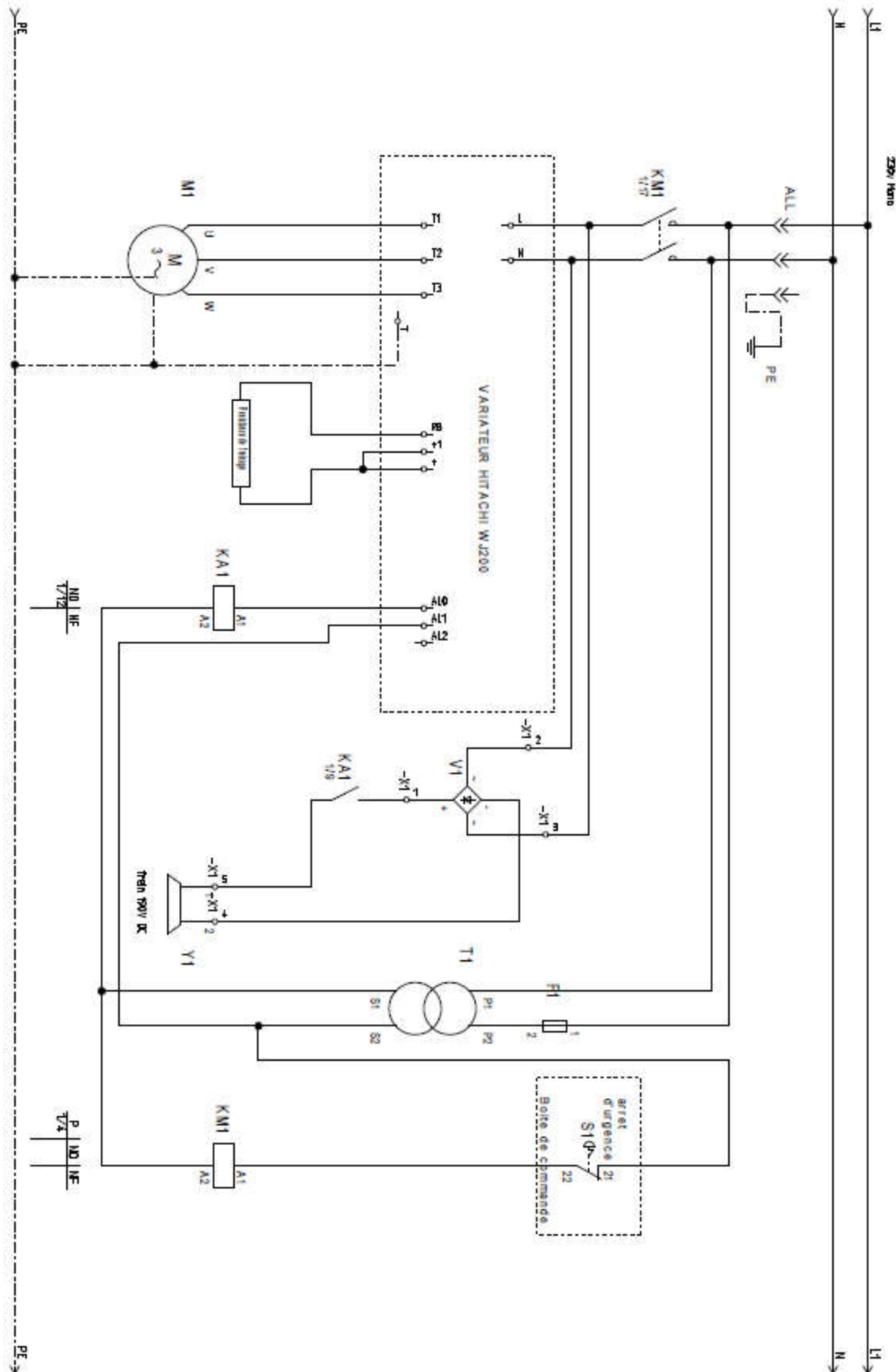

TIRLIFT 2 speed variation 230 V (single-phase) (continuation)

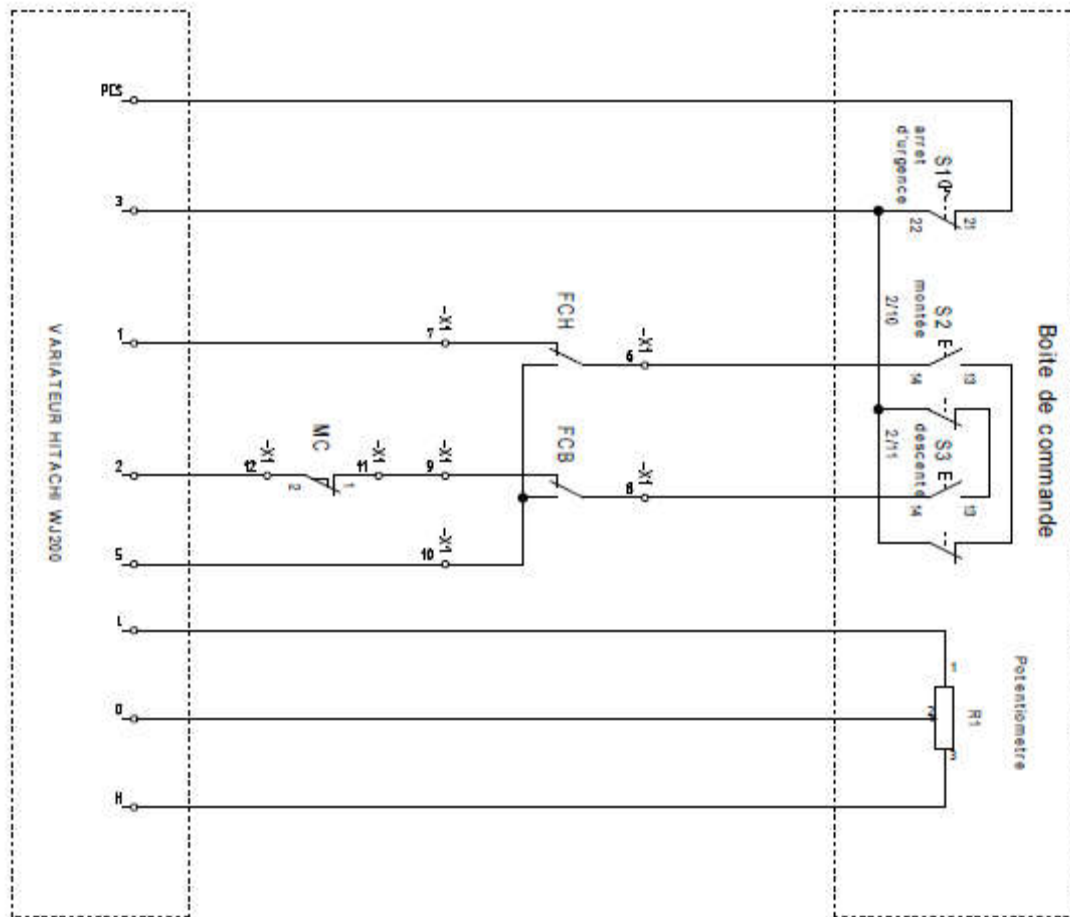

TIRLIFT 2 speed variation 400 V (three-phase)

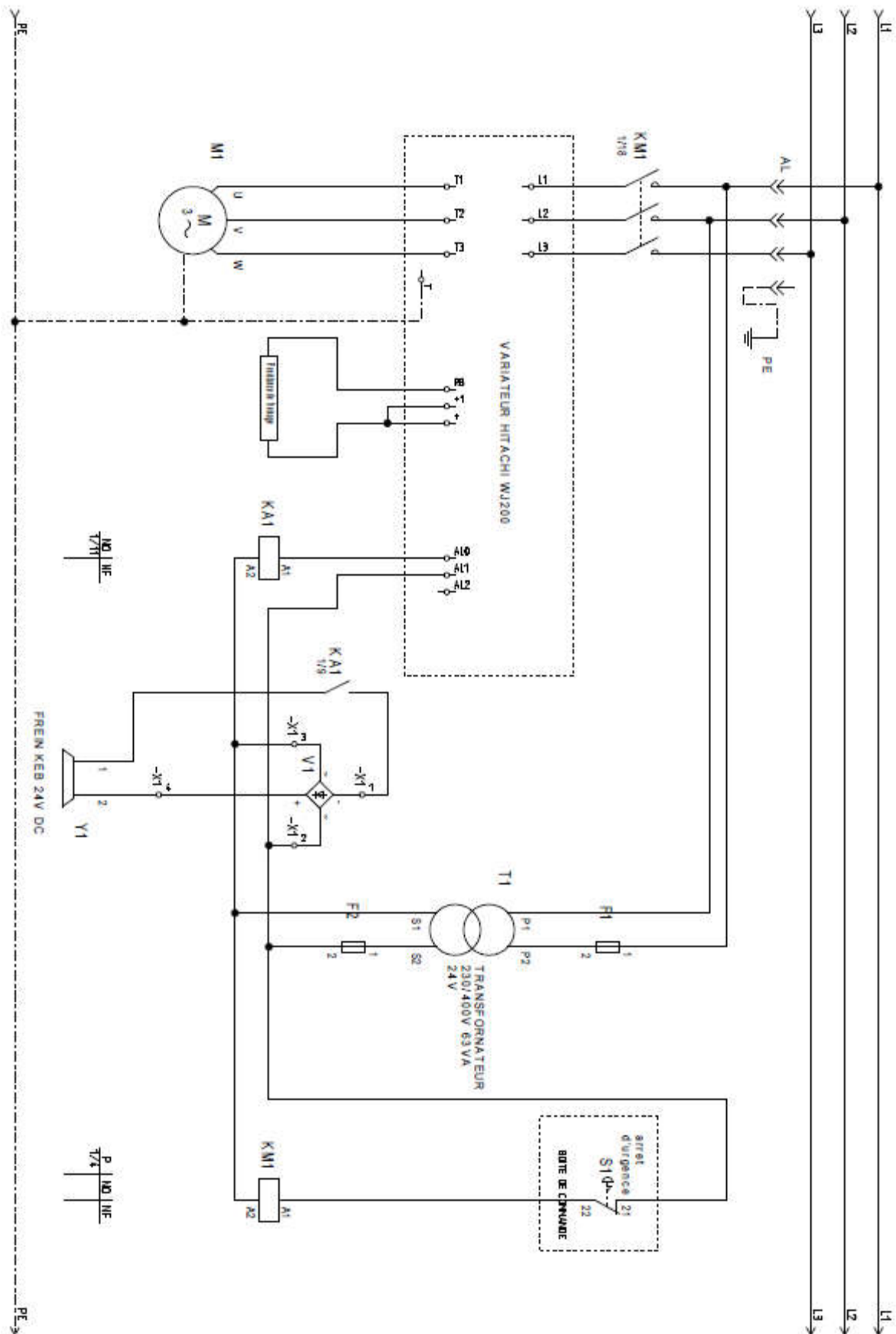

TIRLIFT 2 speed variation 400 V (three-phase) (continuation)

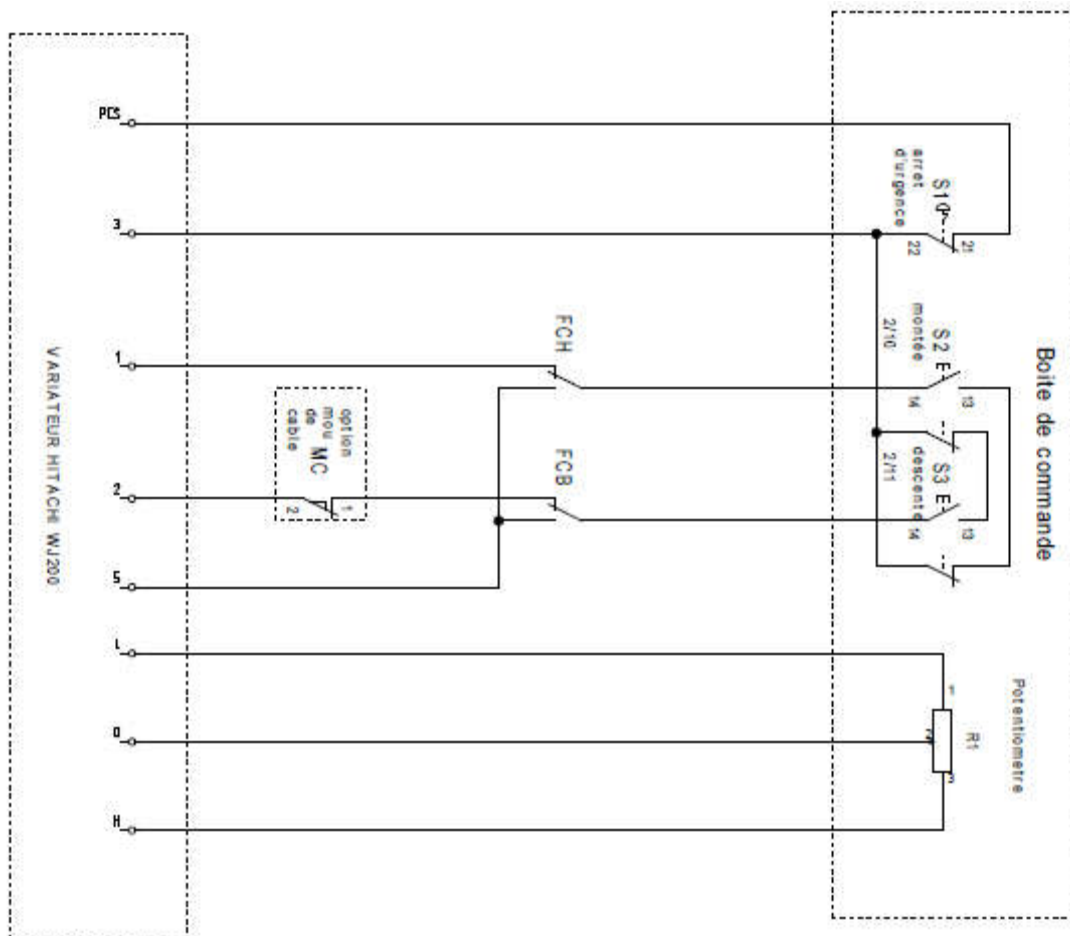

## C- Exploded views

### TIRLIFT 2 250 to 500 kg – Low voltage control

THE SERIAL NUMBER MUST BE SPECIFIED FOR ALL SPARE PART ORDERS.

Key	Quantity	Designation
01	1	Machined transmission casing 80
02	2	6304 2RS bearing
03	2	Pin 5x20
04	1	1.1 kW three-phase motor, electromagnetic brake
05	1	Spacer
06	4	M6x25 CHC screw
07	1	99-tooth wheel
08	1	6x6 key
09	1	16-tooth sprocket wheel
10	2	6206 2RS bearing
11	1	121x230 smooth drum
12	1	99-tooth wheel
13	1	Washer L Ø16

Key	Quantity	Designation
14	1	M16-30 hex head screw
15	1	NBR seal Ø3
16	1	Transmission cover
17	13	M6x16 CHC screw
18	3	Tie
19	1	Protective grate
20	1	External casing
21	3	M10x40 CHC screw
22	1	Box mounting
23	2	M5x10 STAINLESS STEEL hex socket button head screw
24	1	SE limit switch
25	1	SE LV unit
26	1	LV remote control

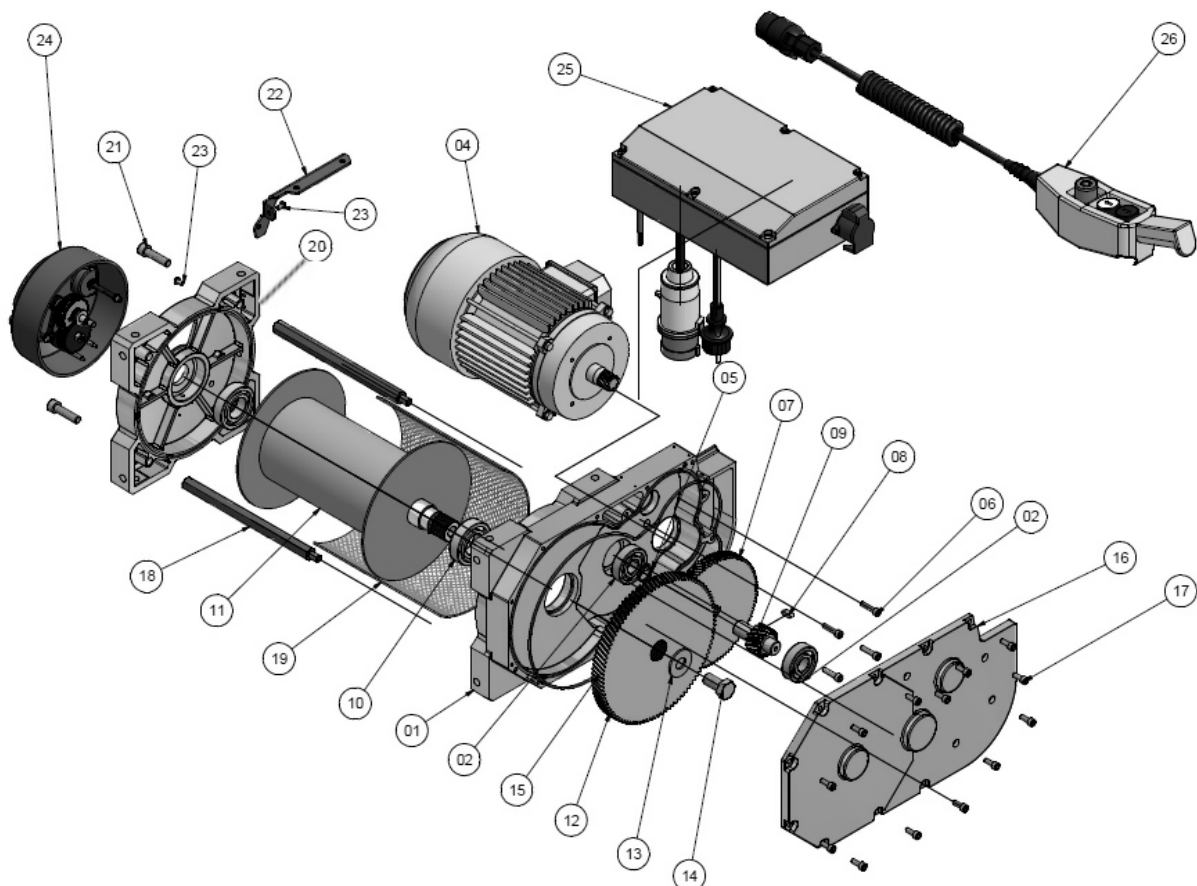

**TIRLIFT 2 600 to 1500 kg – Low voltage control**

**THE SERIAL NUMBER MUST BE SPECIFIED FOR ALL SPARE PART ORDERS.**

Key	Quantity	Designation
1	1	Motor transmission casing
2	2	6306 2RS bearing
3	2	Pin
4	1	Motor
5	2	Spacer
6	17	M8x30 CHC screw
7	1	Wheel
8	1	6x6x15 key
9	1	Sprocket wheel
10	1	6210 2RS bearing
11	1	Drum
12	1	Wheel
13	1	Washer
14	1	M16-30 hex head screw
15	1	Joint
16	1	Transmission cover
18	3	Tie
19	1	Protection
20	1	External casing

Key	Quantity	Designation
21	3	M12x50 CHC screw
22	1	Lower box mounting
23	2	M5x16 hex socket button
24	1	Limit switch
25	1	Electrical unit cover
31	1	Spacer
32	2	6004 2RS bearing
33	1	Wheel
34	1	Sprocket wheel
42	1	Sprocket wheel
43	1	8x7x20 key
44	1	External retaining ring 90x3
45	1	Watertight ring
46	1	Watertight ring
47	1	6208 2RS bearing
48	1	Watertight ring
49	1	M10-35 hex head screw
50	1	W Ø10 washer

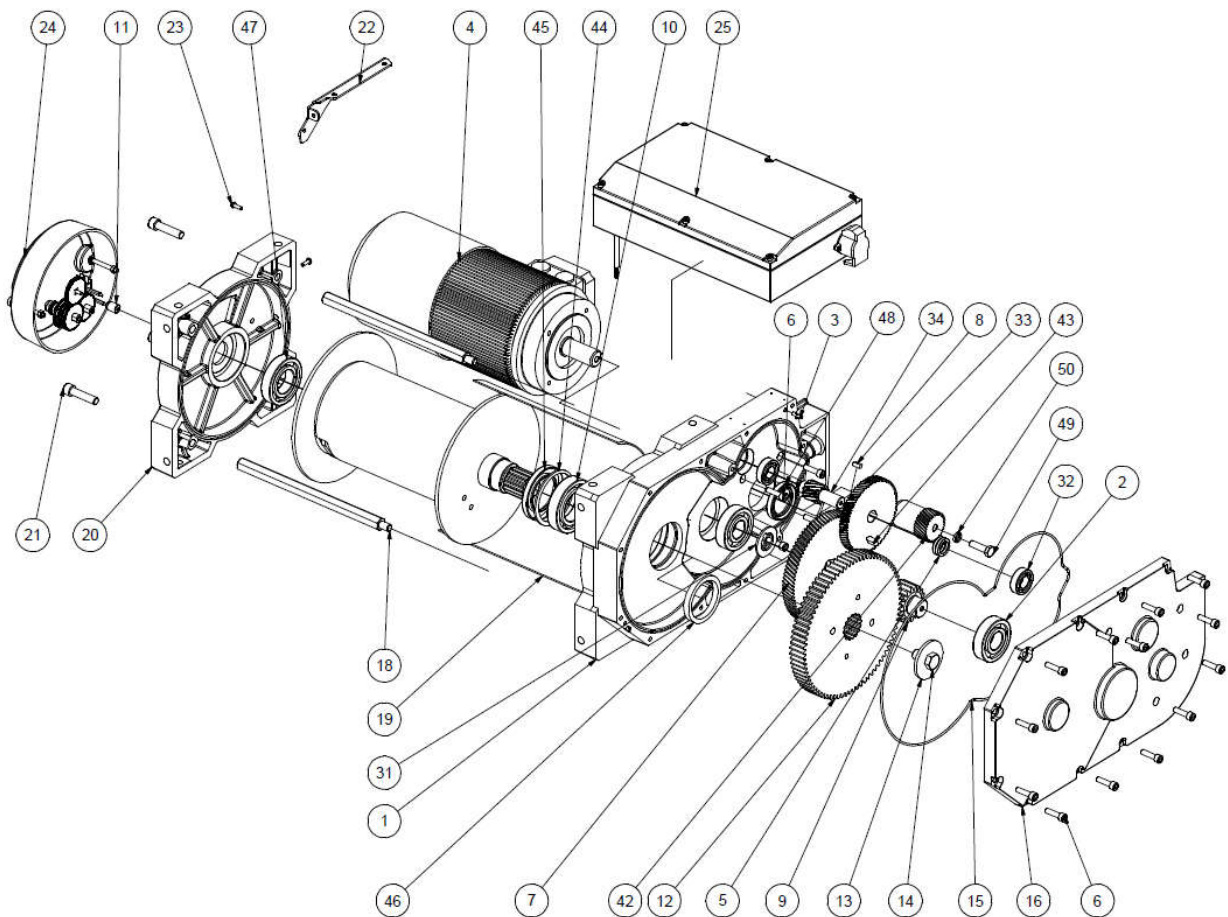



**TIRLIFT 2 250 to 500 kg – Variable speed models**

**THE SERIAL NUMBER MUST BE SPECIFIED FOR ALL SPARE PART ORDERS.**

Key	Quantity	Designation
01	1	Machined transmission casing 80
02	2	6304 2RS bearing
03	2	Pin 5x20
04	1	1.1 kW three-phase motor, electromagnetic brake
05	1	Spacer
06	4	M6x25 CHC screw
07	1	99-tooth wheel
08	1	6x6 key
09	1	16-tooth sprocket wheel
10	2	6206 2RS bearing
11	1	121x230 smooth drum
12	1	99-tooth wheel
13	1	Washer L Ø16

Key	Quantity	Designation
14	1	M16-30 hex head screw
15	1	NBR seal Ø3
16	1	Transmission cover
17	13	M6x16 CHC screw
18	3	Tie
19	1	Protective grate
20	1	External casing
21	3	M10x40 CHC screw
22	1	Box mounting
23	2	M5x10 STAINLESS STEEL hex socket button head screw
24	1	SE limit switch
25	1	SE Speed variator unit
26	1	Speed variation remote control

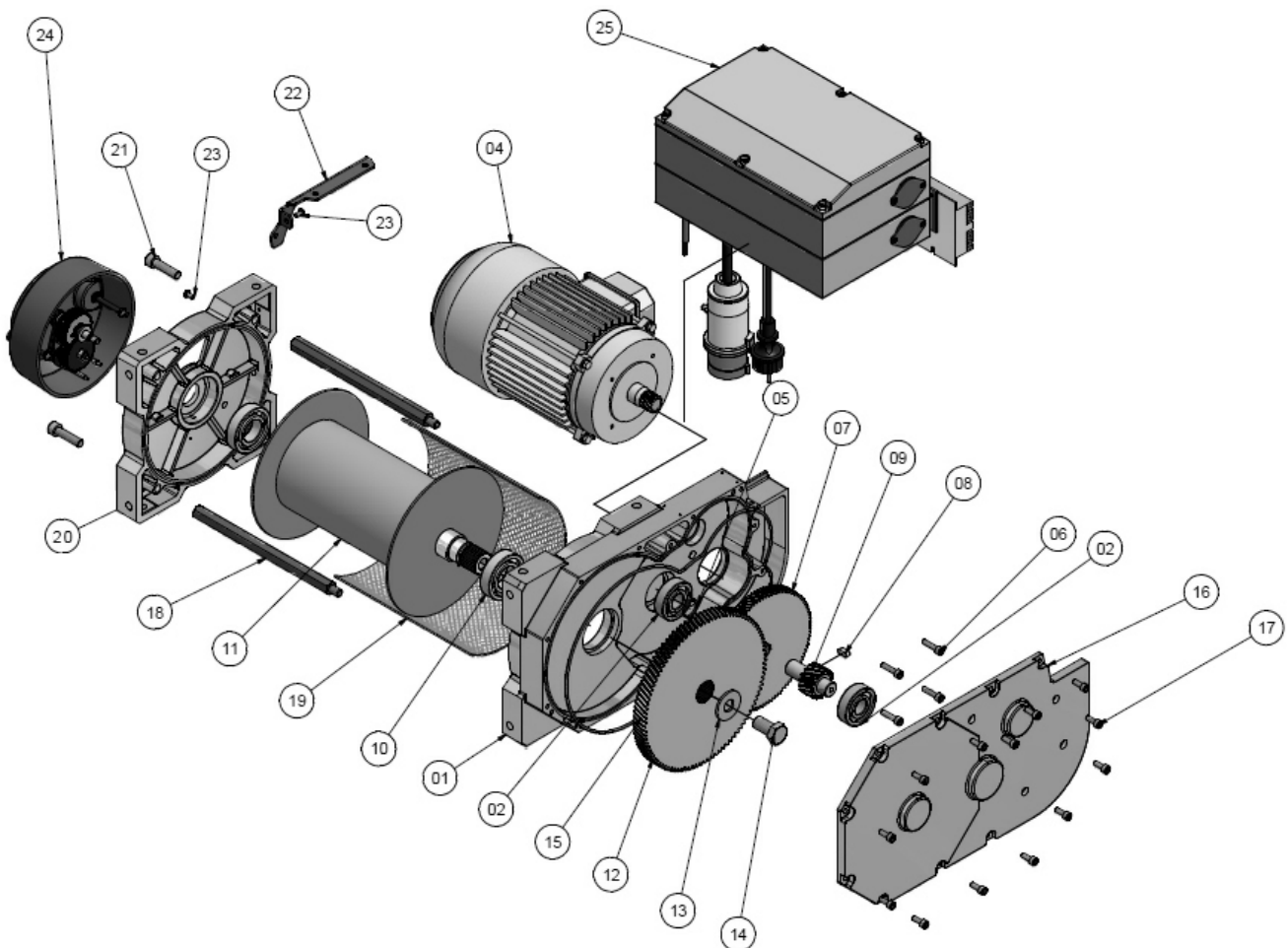



**TIRLIFT 2 600 to 1500 kg – Variable speed models**

**THE SERIAL NUMBER MUST BE SPECIFIED FOR ALL SPARE PART ORDERS.**

Key	Quantity	Designation
1	1	Motor transmission casing
2	2	6306 2RS bearing
3	2	Pin
4	1	Motor
5	2	Spacer
6	17	M8x30 CHC screw
7	1	Wheel
8	1	6x6x15 key
9	1	Sprocket wheel
10	1	6210 2RS bearing
11	1	Drum
12	1	Wheel
13	1	Washer
14	1	M16-30 hex head screw
15	1	Joint
16	1	Transmission cover
18	3	Tie
19	1	Protection
20	1	External casing

Key	Quantity	Designation
21	3	M12x50 CHC screw
22	1	Lower box mounting
23	2	M5x16 hex socket button head screw
24	1	Limit switch
25	1	Electrical unit cover
31	1	Spacer
32	2	6004 2RS bearing
33	1	Wheel
34	1	Sprocket wheel
42	1	Sprocket wheel
43	1	8x7x20 key
44	1	External retaining ring 90x3
45	1	Watertight ring
46	1	Watertight ring
47	1	6208 2RS bearing
48	1	Watertight ring
49	1	M10-35 hex head screw
50	1	W Ø10 washer

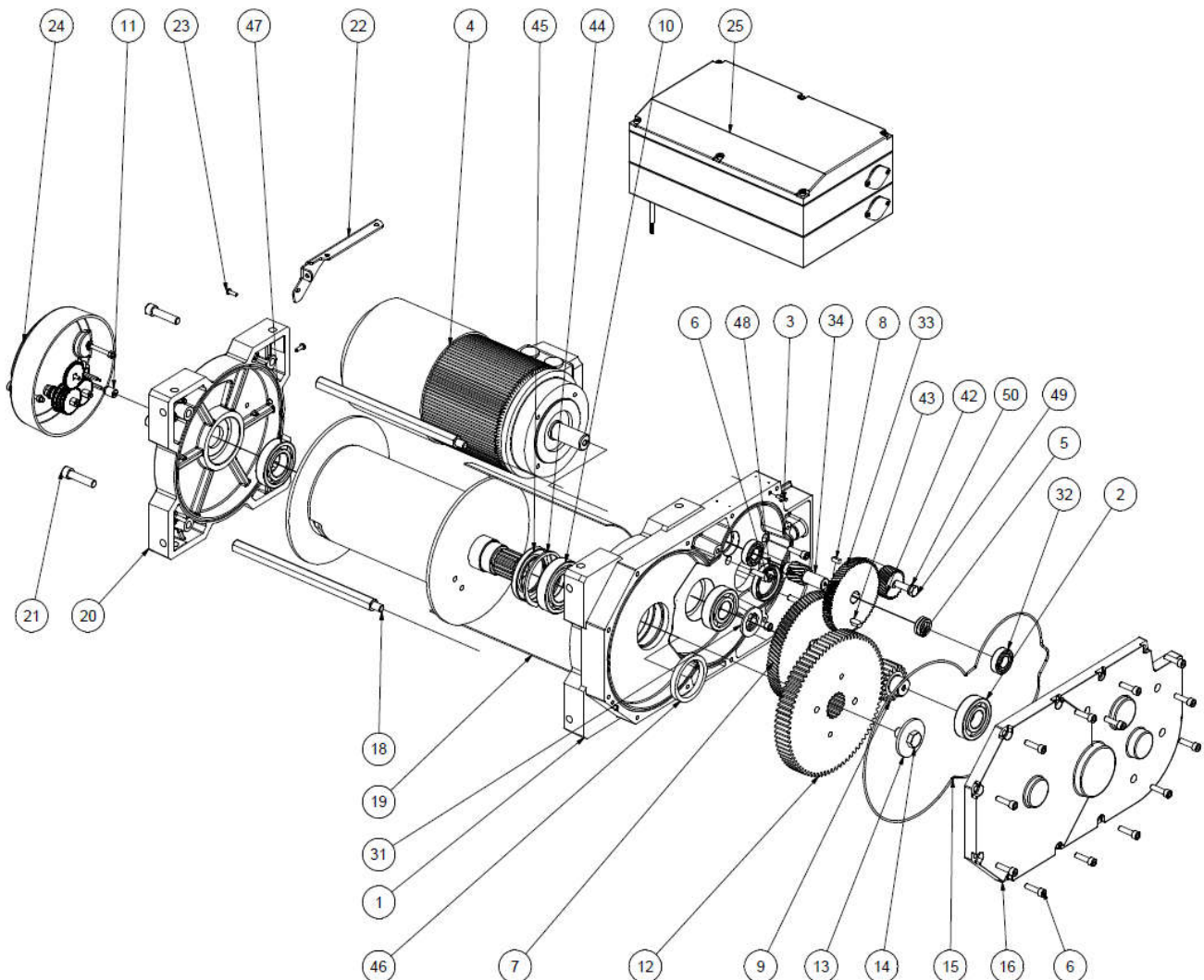

## D- Optional equipment

### ➤ End limit switches (speed variation and Low Voltage versions)

Easy to adjust, this system guarantees safety by preventing upper and lower overruns.



### ➤ Trouble shooting hand wheel and brake release

The occasional use of this equipment requires the presence of two people for simultaneous action on the brake lever and hand wheel.

**Very important:** do not release the brake without **holding** the wheel.

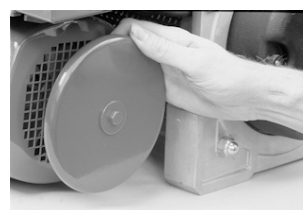

### ➤ Second rope clamp

Allows you to lift a load using several ropes or facilitates a two-way system.



### ➤ Rope slack switch

This automatically stops the winch when the rope is not taut (for example during descent when an obstacle is blocking the load).

If the rope output angle is changed, the positioning of the electrical contact can be adjusted by turning the screw.



### ➤ Tubular Frame (TIRLIFT 2 250 to 500 kg)

- The TIRLIFT 2 with tubular frame is used in particular on small sites and for renovation work.
- Its tubular frame makes it very easy to handle and provides sufficient protection against knocks.
- The unique shape of its feet allow for two attachment methods:
  - Bolting: using the 12 mm holes
  - Stabilisation: using the 50 mm scaffolding tubes passing through the inside of the feet.



➤ **Grooved drum**

Facilitates correct winding of the rope on the first layer. Essential when installing a two-way system.

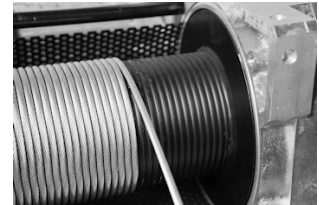

➤ **Electronic load limiter**

➤ **With CROUZET limiter**

**The winch is adjusted in the factory with the electrical voltage indicated on the test report enclosed with this instruction manual. If this voltage is different in the place of use, the setting must be readjusted.**

In the event of overloading of the winch, a load limitation by motor current measurement cuts the lift control.

Once you have identified and eliminated the cause of the load limiter activation, use the key-activated turning button on the right of the unit to reset the load limiter and use the winch again.

Adjust the sensitivity of the load limiter by adjusting the "I value" on the limiter using a small flat screwdriver:

⇒ the load limiter is adjusted in the factory to the value of about 110% of its MCU.

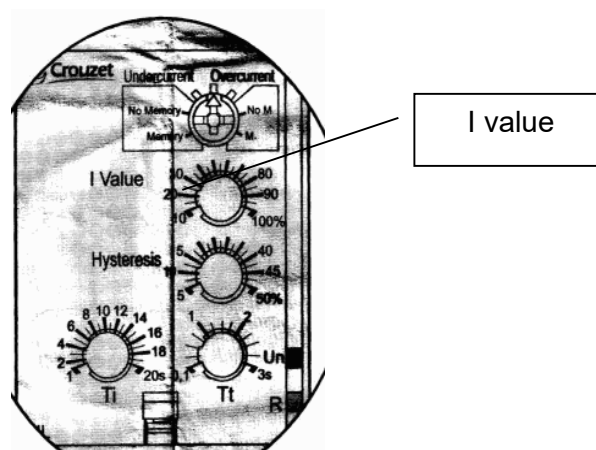
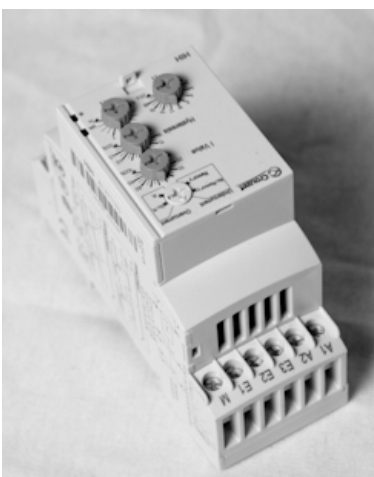

**IMPORTANT!**

**Setting the threshold too high may lead to major risks both for the equipment and the operators.**

**DANGER: RISK OF ELECTROCUTION, EXPLOSION OR ELECTRIC ARC.**

Switch the power off before installing, wiring or performing a maintenance operation.  
Check that the power supply voltage of the product, with its tolerances, is compatible with that of the network.

Non compliance with this instruction will cause death or serious injury.

**WARNING: UNEXPECTED OPERATION OF THE EQUIPMENT**

This product must not be used in the capacity of the critical functions of a safety machine.  
Wherever there is a risk to the personnel and/or equipment, use the appropriate hard-wired safety lugs.

Please do not disassemble, repair or modify the product.

Respect the installation and operating conditions of the product described in this document.

Non-compliance with this directive may cause death, serious bodily injury or material damage.







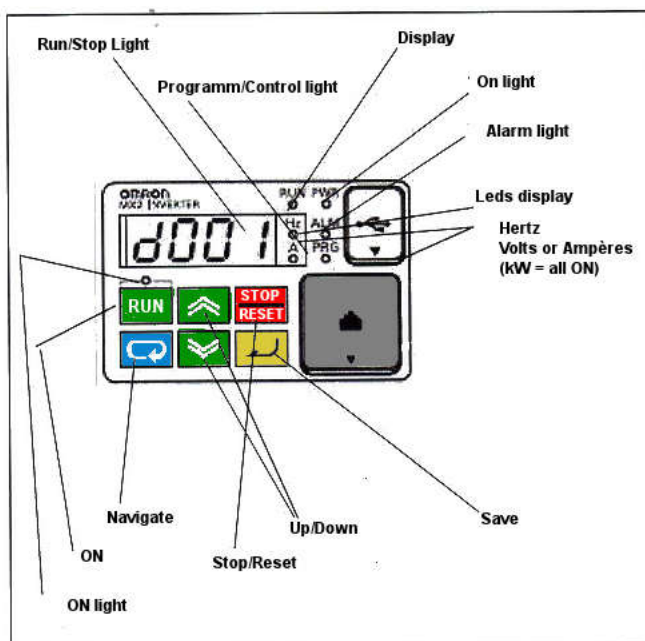











Electrical equipment must be installed, operated and serviced by qualified personnel.

➤ **With variable frequency drive**

**Use of the integrated keyboard**



Adjusting limitation (current) using the frequency drive:

- 1/ Winch switched on displays **0000**, press save button 
- 2/ Press browse button  several times until **C001** is displayed
- 3/ Press up button  until **C041** is displayed
- 4/ Press save button 
- 5/ A value in amperes is displayed: increase to the maximum using the up button , then press save 
- 6/ Press the browse button  until **D001** is displayed
- 7/ Press the up button  until **D002** is displayed (current reading in ampere)
- 8/ Press save button  **0000** is displayed (Load winch at the required stop value)
- 9/ Activate lifting (direct ampere reading). For example, 5 A at XX kg stop required.
- 10/ Return to **C041** using the save button , then browse , save  and press up . Adjust to 5A (for example) using the up  or down  button and save .
- 11/ Press browse  **D001** then save  and use.

To reset to the default setting E12 press the stop reset button  or the ignition key on the AE unit.







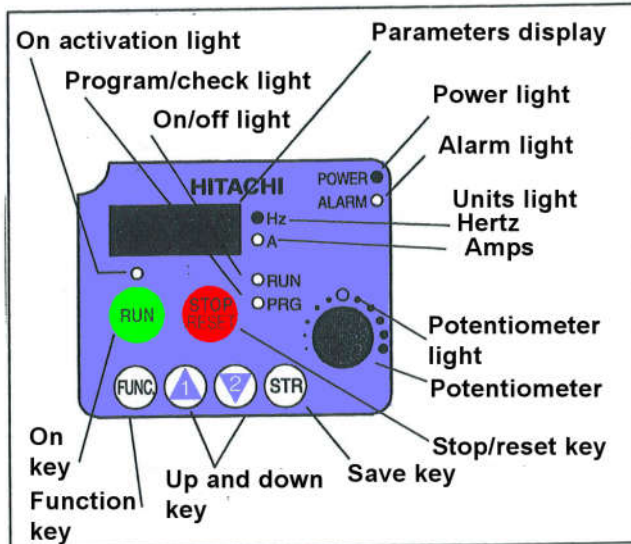











➤ **With SJ200 inverter (HITACHI model)**

Use of the integrated keyboard



Adjusting limitation (current) using the SJ200 inverter:

- 1/ Winch switched on displays **0000**,  button displays **D001**
- 2/ Arrow 2 = H - - - .
- 3/ Arrow 2 = C - - - .
- 4/ Press  = **C001** then arrow 1 until **C041** is displayed
- 5/ Press , the value in ampere is displayed, press  until the maximum value then press  to confirm
- 6/ Press  returns to **C041**, then press the  button three times for C - - -
- 7/ Press  for **D002** then press , **0000** is displayed, direct ampere reading
- 8/ Load the winch at the required value, then test and take ampere reading (e.g. 5.00 A)
- 9/ Return to C041 to adjust the value determined in **D002**: press  + press  three times, press  + press  until **C041** value is adjusted (e.g. 5.00 A or lower to stop below the reading) in amperes then press  to confirm

10/ Press  for C - - - then arrow 1 until **D001** then press  and press  for frequency reading

➤ **Disengaging drum**

In order to avoid uncontrolled movements of the load as well as damage to the device, the drum should only be disengaged when no force is applied to the rope.

Systematically verify that all tension has been removed from the rope before performing the operation. This can be done by pulling the control button (Ref. 3 21706) outwards.

The "disengaged" position is maintained by turning the button by one quarter of a turn. The drum is re-engaged by turning the button by a further quarter of a turn and allowing the drum to rotate freely.

When the control button is once more in contact with the cover, the system is correctly engaged. The device should only be loaded again when this condition is met.



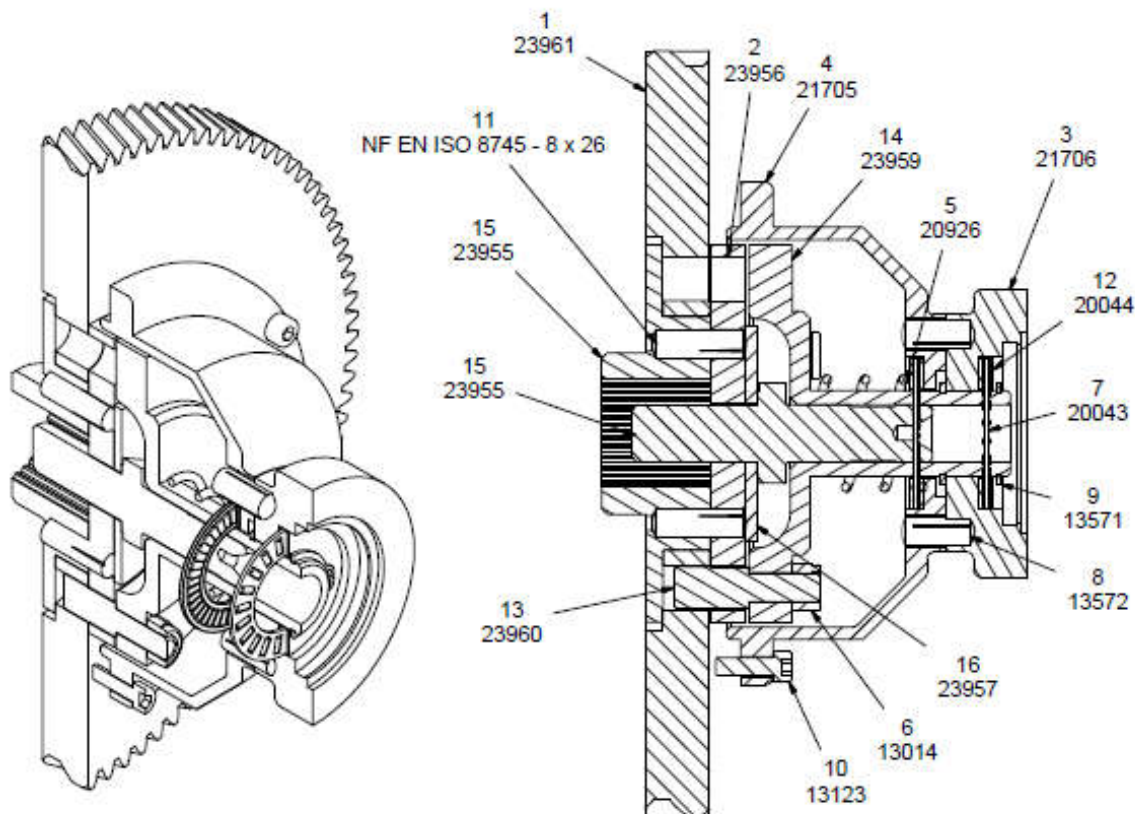

Key	Quantity	Part No.	Designation
1	1	23961	TD train 3-3 16-99 m2 beta20 wheel
2	1	23956	Drive plate
3	1	21706	Disengaging button
4	1	21705	Disengaging cover
5	1	20926	Disengaging spring
6	3	13014	H FR M8 nut
7	3	20043	AXK2542 needle thrust bearing
8	2	13572	8x20 fluted pin
9	2	13571	24x1.2 ext. retaining ring
10	3	13123	8x26 fluted pins
11	6	NF EN ISO 8745 - 8 x 26	C HC M5x16 screw
12	6	20044	AS2542 thrust washer
13	3	23960	Disengaging pawl
14	1	23959	Block
15	1	23955	Fluted hub
16	1	23957	Compression washer
17	1	23958	Hub clamping screw

➤ **Rocking winch**

This system carries out optimum rope winding by naturally guiding the winch under the action of the winding/unwinding effort.



Operating principle:

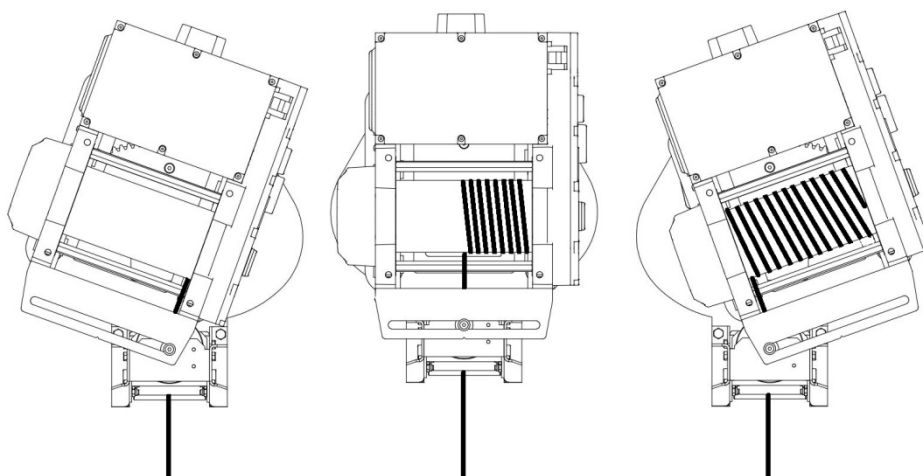

As a result, the conditions necessary for its proper operation are:

- Sufficient, constant tension on the rope to make the device move during winding and unwinding.  
This condition can easily be achieved in lifting operations by installing an appropriately dimensioned counterweight at the end of the rope.
- Free movement of the mobile unit, which means:
  - Perfectly horizontal installation of the chassis,
  - No obstacles to winch moving,
  - Clean rolling surfaces on the ball units.

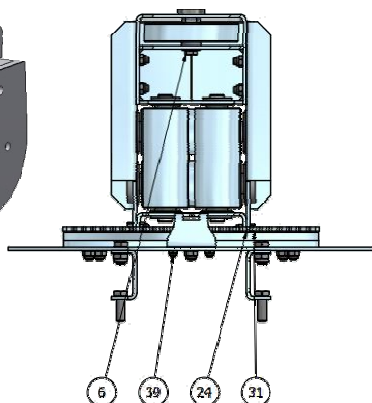
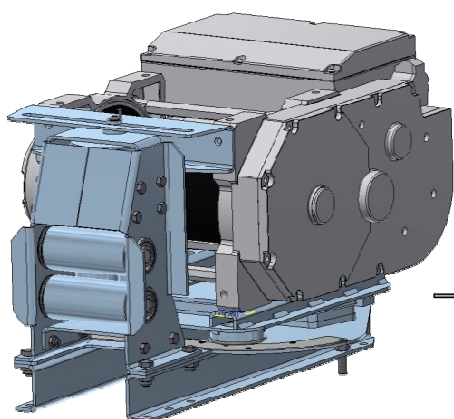

Fixed part

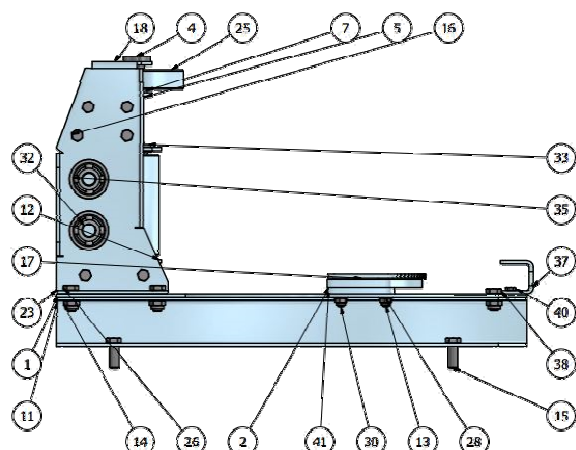

Fixed part

**TIRLIFT 2 250-500 (standard drum)**

Ref.	Qty	No.	Description
1	1	57793	Fixed plate
2	1	57005	Smooth crown gear
3	2	3083	6003 2RS ball bearing
4	1	57781	Tensioner axle
5	1	20045	NF E 25-514 L Ø8 washer
6	1	13064	ISO 4017 M8-16 hex head screw
7	1	57785	Pulley spacer
11	2	57797	U plate
12	1	57791	Lower roller mounting
13	17	13014	DIN985 M8 nylon lock nut
14	6	13020	DIN985 M10 nylon lock nut
15	4	13076	ISO 4017 M10-30 hex head screw
16	6	ISO 4018 M8x20	ISO 4018 - M8 x 20 hex head screw
17	1	57777	Machined cogged plate
18	1	57799	SE_upper support
32	4	57805	Roller
33	4	2964	6003 2RS RN ball bearing
23	1	57788	Reinforcement
24	1	57789	Symmetrical reinforcement
25	1	57235	Tensioner
26	4	13075	ISO 4017 M10-25 hex head screw
28	10	13210	NF E 25-514 M Ø8 washer
30	5	ISO 10642 - M8 x 40	Flat countersunk head socket cap screw
31	6	I4018 M8x20_v1_MIR	ISO 4018 - M8 x 20 hex head screw
35	4	6303 NR	Deep groove ball bearings - single row - with snap ring groove- for Ø17 shaft
37	1	58010	Rear bracket plate
38	2	13074	ISO 4017 M10-20 hex head screw
39	2	13011	DIN985 M6 nylon lock nut
40	2	13058	ISO 4017 M6-16 hex head screw
41	1	58009	Rack-and-pinion shim

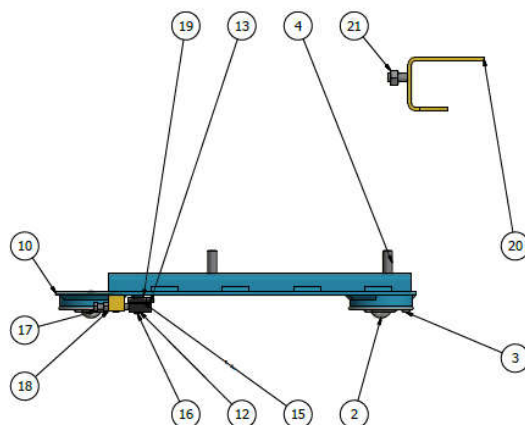

Moving part

TIRLIFT 2 250-500 (standard drum)							
Ref.	Qty	No.	Description	Ref.	Qty	No.	Description
2	3	687 590	Pressure ball	16	4	13060	ISO 4017 M6-25 hex head screw
3	9	13703	ISO 7380 M5 x 16 stainless steel hex socket flattened half round head screw	17	2	13062	ISO 4017 M6-35 hex head screw
4	4	13076	ISO 4017 M10-30 hex head screw	18	2	13010	NF E 24032 M6 nut
10	1	57798	SE_moving table	19	4	58007	Shim
12	1	57845	Smooth rack plate	20	1	58006	SE_Tensioner rail
13	1	57846	Cogged rack plate	21	2	13018	NF E 24032 M10 nut
15	4	13209	NF E 25-514 M Ø6 washer				