

ZHV-HPR[®]



Hand chain block with low headroom trolley construction for loads from 500 to 50,000 kg

Technical characteristics

- > Epoxy Painting (min. 50 µm).
- > Machined chain sprocket and gears provide smoother, more efficient operation.
- > High strength alloy steel load chain with corrosion-resistant galvanized.
- > Galvanized hand chain.
- > ZHV's compact design offers safety together with reduced weight. Ideal for construction and maintenance applications.
- > Steel casing solidly protects chain sprocket, gearcase and handwheel cover.

- > Upper and lower alloy steel ISO hooks with safety latches.
- > Delivered with CE certificate.

Options available

- > See options of ZHV-CHZ.

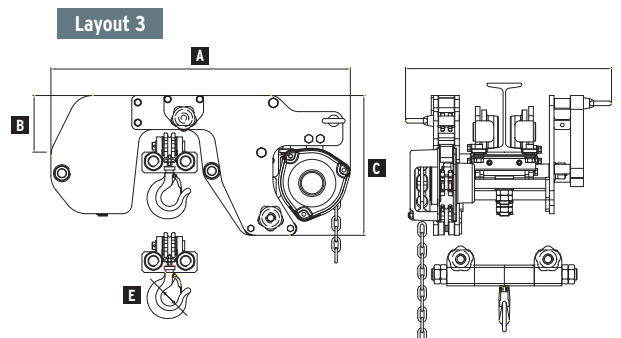
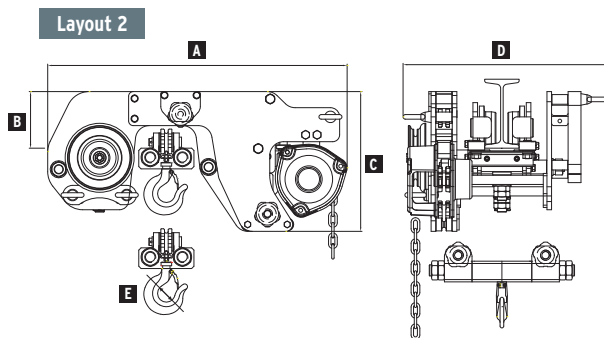
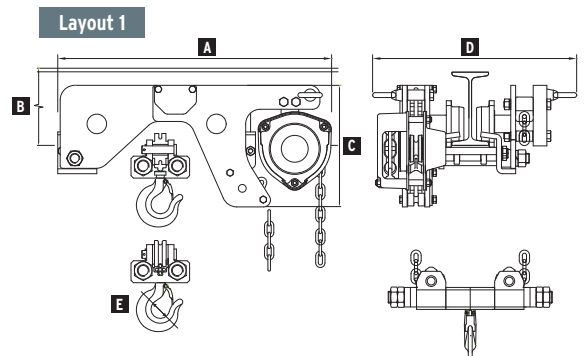

Load (kg)	Dimensions in mm					Standard height of lift (m)	Length of hand chain (m)	Lifting chain size (mm)	Number of falls	Flange width (mm)	Min radius (mm)	Weight (kg)
	A	B	C	D	ØE							
Layout 1 : Hand chain block ZHR with short headroom push trolley (HPR)												
1000	561	150	-	418	38	2,5	2,0	Ø 6,3 x P19,0	2	75 ~ 125	2900	61
2000	560,5	150	285	372,5	41	3,0	2,5	Ø 7,1 x P20,2	2	75 ~ 150	3200	64
Layout 2 : Hand chain block ZHR with short headroom geared trolley (HPR)												
1000	652	150	304	448	38	2,5	2,0	Ø 6,3 x P 19,0	2	75 ~ 125	2900	59
2000	560,5	150	285	463	41	3,0	2,5	Ø 7,1 x P 20,2	2	75 ~ 150	3200	63
3000	691	300	370	568	58	3,0	2,5	Ø 7,9 x P 23,0	2	100 ~ 150	3500	150
5000	794	300	407	644	64	3,0	3,0	Ø 11,1 x P 33,3	2	125 ~ 175	-	195
10000	995	350	643	640	86	3,5	3,5	Ø 11,1 x P 33,3	4	150 ~ 190	-	460
20000	1460	285	660	1100	-	3,5	3,5	Ø 11,1 x P 33,3	6	150 ~ 190	-	850
30000	1650	600	655	894	130	3,5	3,5	Ø 11,1 x P 33,3	10	175 ~ 190	-	1320
Layout : Hand chain block ZHR with short headroom geared trolley for curved beam (HPNB)												
1000	652	123	304	448	-	2,5	2,0	Ø 6,3 x P 19,0	2	75 ~ 125	1000	98
Layout 3 : Hand chain block ZHR with short headroom push trolley for curved beam (HPNB)												
1000	652	123	304	448	-	2,5	2,0	Ø 6,3 x P 19,0	2	75 ~ 125	1000	93